

Proceedings of the 33RD International Seating Symposium



International Seating Symposium

Be Empowered

March 2-4, 2017



RSTce

Department of Rehabilitation Science and Technology

Continuing Education

School of Health and Rehabilitation Sciences
University of Pittsburgh

Course Director: Mark R. Schmeler, PhD, OTR/L, ATP

In Collaboration with:

- Sunny Hill Health Centre for Children
- European Seating Symposium
- Latin American Seating Symposium
- Asia Pacific Region Seating Symposium
- International Society of Wheelchair Professionals

Gaylord Opryland Hotel & Convention Center • Nashville, TN

The ISS Would Like to Acknowledge the Following Supporters

Platinum:



Yes, you can.[®]

permobil

THE POWER OF MOBILITY™



QUANTUM[®]

Silver:



2017 ISS Advisory Board:

Ana Allegretti, PhD, OTR, ATP, *University of Texas Health Sciences, San Antonio*

Kendra Betz, MSPT, ATP, *Veterans Health Administration, National Center for Patient Safety*

Jim Black, *TiLite/Permobil*

Gerry Dickerson, CRTS, ATP, *Medstar Surgical Inc.*

Carmen DiGiovine, PhD, RET, ATP/SMS, *The Ohio State University*

Doug Gayton, ATP, *G.F. Strong Rehabilitation Centre*

Wayne Grapes, *The Brewis Group*

Simon Hall, *Central Remedial Clinic, European Seating Symposium*

Jean Minkel, PT, ATP, *Minkel Consulting*

2017 ISS - RSTCE Staff:

Mark R. Schmeler, PhD, OTR/L, ATP, *ISS Director*

Rory A. Cooper, PhD, *Director, Department of Rehabilitation Science & Technology*

Richard M. Schein, PhD, MPH, *Research Scientist*

Meghan E. Wander, MPA Ed, *ISS Manager, Continuing Education Manager*

Bethany L. Semancik, BSc Adm, *Continuing Education Administrator*

Karl A. Kemmerer, MS, *Online Continuing Education Coordinator*

Joseph K. Ruffing, *Graphics and Communications Specialist*

The University of Pittsburgh, Department of Rehabilitation Science & Technology Continuing Education Program (RSTCE) is the host of the 33rd International Seating Symposium (ISS).

The ISS is the leading educational and scientific conference in the field of wheelchair seating and mobility as well as, related technologies. The 33rd ISS expects to host over 2000 national and international attendees representing multiple countries and backgrounds.

The Symposium will include scientific and clinical papers, research forums, in-depth workshops, panel sessions, and an extensive exhibit hall. Presentations will address wheeled mobility and seating challenges, in addition to solutions for people with disabilities across the lifespan. Conditions such as neuromuscular disorders, spinal cord injury and diseases of the spinal cord, orthopedic disorders, systemic conditions, obesity, and polytrauma will also be addressed.

The conference takes place from March 2 to March 4, 2017 (pre-symposium workshops February 28 to March 1, 2017) at the Gaylord Opryland Resort and Convention Center in Nashville, TN USA.

The 33rd ISS features

- Over 100 sessions, including: pre-symposium workshops, plenary sessions, instructional courses, papers, and posters
- A 70,000 square foot Exhibition Hall with over 100 exhibitors of products and services, with both public and attendee-only hours
- Thursday night Social Event

Audience

- Assistive Technology Professionals (ATP)
- Seating and Mobility Specialist (SMS)
- Rehabilitation Engineering Technologist (RET)
- Occupational Therapists
- Physical Therapists
- Educators
- Manufacturers
- Product Developers
- People with Disabilities
- Physicians
- Nurses
- Recreational Therapists
- Rehabilitation Engineers & Technicians
- Vocational Rehabilitation Counselors
- Researchers
- Policy Makers

Continuing Education Units

Up to 1.7 Continuing Education Units (CEUs) can be earned by individuals for attending 17 hours of instruction at the main ISS conference sessions. Additional CEUs are awarded for pre-conference workshops. (0.4 CEUs for half-day workshops, 0.8 CEUs for full-day workshops)

CEU Certificates

CEU Certificates are issued electronically via email attachment through the www.rstce.org portal. After attending the 33rd ISS, attendees are required to log back into the portal and complete an overall ISS conference evaluation and course evaluations for individual sessions.

A unique course identification code is provided at the end of each session that must be entered. The CEUs certificate is prorated based on sessions actually attended with course evaluations and unique session codes.

Information for Specific Credentials

The University of Pittsburgh, School of Health and Rehabilitation Sciences awards Continuing Education Units to individuals who enroll in certain educational activities. The CEU is designated to give recognition to individuals who continue their education in order to stay current in their profession. (One CEU is equivalent to 10 hours of participation in an organized continuing education activity.) Each person should claim only those hours of credit that they actually spent in the educational activity.

- **Occupational Therapy Practitioners**

The National Board for Certification in Occupational Therapy, Inc. (NBCOT) accepts the University's CEUs as PDU's for OTR and COTA re-certification. Individual State OT Practice Boards may have additional requirements.

- **Physical Therapy Practitioners**

As a CAPTE accredited program, the University of Pittsburgh School of Health and Rehabilitation Sciences is a pre-approved provider of CE for Pennsylvania PTs and PTAs. Physical Therapy practitioners outside of Pennsylvania should verify with their local practice boards to determine if there is reciprocity or if other necessary procedures are required to apply University of Pittsburgh CEUs for their jurisdiction.

- **Assistive Technology Professionals (ATPs)**

In addition, RSTCE CEUs are accepted by the Rehabilitation Engineering & Assistive Technology Society of North America (RESNA) for certification and re-certification of the Assistive Technology Professional (ATP). The National Registry of Rehabilitation Technology Suppliers (NRRTS) also accepts the University of Pittsburgh CEUs for the Certified Rehabilitation Technology Supplier (CRTS) credential.

Table of Contents

- 3 • 2017 ISS Advisory Board:
- 3 • 2017 ISS - RSTCE Staff:
- 4 • Features, Audience, CEU information
- 5 • Table of Contents
- 9 • Faculty
- 35 • Exhibitors
- 49 • **Thursday March 2, 2017**
- 51 • SS1.1: Virtual Analysis of the Posture Effect on Skin Integrity
- 53 • SS1.2: Outcomes: Just Do It – Circa 1994
- 55 • SS1.3: What is Data Science and How Will it Impact Rehabilitation Science?
- 57 • IC01: Using The Science of Materials to Compare Wheelchair Cushions
- 59 • IC02: Complex Rehab Technology Update
- 61 • IC03: What's in a Back
- 63 • IC04: Update on Functional Mobility Assessment and Uniform Data Set
- 65 • IC05: The Integration of Wheelchair Mobility and Home Accessibility
- 67 • IC06: Go Baby Go? Stakeholder Perspectives of Powered Mobility Provision
- 71 • IC07: Postural and Functional Benefits of Power Wheelchair Operation at Midline
- 73 • IC08: Development of Wheelchair Standards for Less-Resourced Settings
- 77 • PS1.1: Health Outcomes of Wheelchair Seated Posture
- 79 • PS1.2: Developing a Seating Intervention for Older Veterans
- 81 • PS1.3: The Experience of Spinal Cord Injury and Wheelchair Use
- 85 • PS1.4: Clinical Training in Seating and Mobility for Entry-level Physical Therapy Students
- 87 • IC09: Understanding Pressure Injuries for Effective Prevention
- 89 • IC10: What's the Latest: Medicare Documentation & Coverage Requirements
- 91 • IC11: Optimizing the Ride: How Manual Wheelchair Configuration Enhances Function
- 93 • IC12: Powered Wheelchair Provision: Current practice and opportunities for success
- 95 • IC13: Posture, the Missing Link in Finite Modeling
- 97 • IC14: Understanding Paediatric Mobility Needs from Parental Perspective
- 99 • IC15: Managing postural deformities through use of Adjustable Micro Modular Seating (AMMS) Systems
- 101 • IC16: Assistive Robotics for Activities of Daily Living
- 105 • PS2.1: Adapting Off-the-Shelf Fitness Wearable for Manual Wheelchair Users
- 109 • PS2.2: Assessment of Seat Elevator User Satisfaction
- 111 • PS2.3: Evaluating Wheelchair Transfer Technique by Microsoft Kinect
- 117 • PS2.4: Transfer Training for Wheelchair Users with Multiple Sclerosis
- 119 • IC17: Early Vs. Late Intervention with Custom Molded Seating
- 121 • IC18: Updating Referral Sources on Medicare Wheelchair Requirements
- 123 • IC19: Environmental and Mobile Device Access for Power Wheelchair Users
- 127 • IC20: Creating a tool to define and evaluate competencies for training positioning and mobility specialists
- 129 • IC21: Past, Present and Future of Tilt & Recline
- 133 • IC22: A Pommel Does What?
- 135 • IC23: A Lifespan Blueprint for DME: Cerebral Palsy
- 137 • IC24: Advances in Upper Body Function, Here Come the Robots!
- 141 • PS3.1: Beyond Mobility: Above Knee Amputee Case Study
- 143 • PS3.2: Advocating Necessity for Bluetooth Power Mobility Integration
- 145 • PS3.3: Outcomes in a Community-Based Wheelchair Seating Clinic

- 147 • PS3.4: Motor Learning Approach for Training Manual Wheelchair Users
- 151 • **Friday March 3, 2017**
- 153 • SS4: Do We Really Need Big Data?
- 155 • IC25: The Other Seat!
- 159 • IC26: Rehab on the Ropes: Round 2 of the CMS Competitive Bid
- 161 • IC27: Positioning the Head
- 163 • IC28: How do we learn the skills to become seating therapists?
- 165 • IC29: What Happens When You Sit? Explaining Seated Buttocks Deformation.
- 169 • IC30: Power Mobility for Children with Multiple Severe Disabilities
- 171 • IC31: Meeting Lifetime Mobility Needs of Spinal Cord Injury and Disease
- 173 • IC32: An Introduction to Hybrid Alternative Driving Systems
- 175 • PS4.1: Effects of Adjusting Wheelchair Configuration on Ramp Propulsion
- 177 • PS4.2: Montana Postural Care Project: A 24-Hour Postural Care Model
- 181 • PS4.3: Adverse Consequences From Wheelchair Breakdowns and Increased Risk of Hospitalization
- 185 • PS4.4: An Ergonomic Comparison of Three Different Seated Transport Devices
- 189 • IC33: Introduction of a Total Shear Force Measurement Device, the iShear.
- 191 • IC34: Mobility Addendums: Getting it Right the FIRST Time!
- 193 • IC35: Are Environmental Control Units (ECUs) a thing of the Past?
- 195 • IC36: Group Wheelchair Skills Training – Setting and Achieving Goals
- 197 • IC37: “School of Power Mobility: Tips for Teaching Power Mobility Skills”
- 199 • IC38: Driving for Change: Ending Barriers and Paving the Way for Play
- 201 • IC39: Conquer the Complexity of Writing a Letter of Medical Necessity
- 203 • IC40: New & Emerging Technologies: How to Ask the Right Questions When Evaluating Mobility Devices
- 205 • PS5.1: Second Generation of a Low-Cost Smart Wheelchair
- 209 • PS5.2: A Global Description of Wheelchair Service Education
- 211 • PS5.3: Development of an Online Wheelchair List for Wheelchair Users (Intermediate)
- 213 • PS5.4: Evaluating the Effectiveness of Hybrid Wheelchair Training
- 217 • IC41: CARF Accreditation in Assistive Technology
- 219 • IC42: Documentation for Complex Rehab Technology: The Ethical Dilemma
- 221 • IC43: Overcoming Barriers to Best Practice: Keep the Client First!
- 223 • IC44: Empowering Practice: Evaluating Seating and Mobility Outcomes
- 227 • IC45: Seeing Opportunities for Success: Visual Factors for Positioning
- 231 • IC46: Assessing Mobility for Those with Cortical Visual Impairment (Intermediate)
- 233 • IC47: Solving Complex Seating Clinic Challenges in an Intense Climate
- 235 • IC48: Rehab Engineers + 3-D Printing + Electronics = Personalized AT
- 237 • PS6.1: Modeling Pressure Injury Conditions Caused by Toilet Seats
- 239 • PS6.2: An MRI Investigation Evaluating Tissue Response to Seat Cushions
- 243 • PS6.3: How a Cushion Can Effectively Protect Against Pressure Injury
- 245 • PS6.4: Factors affecting seating prescription: an evaluation of Watercell® technology in complex static chairs
- 249 • IC49: Custom Molded Seating: Back to the Basics
- 251 • IC50: Power Adjustable Seat Height is Both Reasonable and Necessary!

- 253 • IC51: Advanced Mobility Skills Training for Manual Wheelchair Users
- 257 • IC52: Meeting the Unmet Need: Encouraging and Educating Therapists
- 259 • IC53: Seating the 'Unseatable'
- 263 • IC54: How Much Hip Abduction is Optimal in Sitting, Standing and Lying for Children with Cerebral Palsy?
- 265 • IC55: Adaptive Bathroom Equipment for Adults
- 267 • IC56: An Online Wheelchair Maintenance Training Program for Clinicians
- 271 • PS7.1: Interrater reliability of the Wheelchair Components Questionnaire for Condition
- 273 • PS7.2: Proper Wheelchair Measurement and Fit
- 275 • PS7.3: Wheelchair Skills Training: University Course vs. Boot Camp
- 279 • PS7.4: Reliability of the Aspects of Wheelchair Mobility Protocol
- 281 • IC57: The Seating Clinic: Business Realities for Success
- 285 • IC59: Integration of Powered Mobility, AAC, & Computers
- 289 • IC60: Ideas to Innovation: Student Design Projects and Capstone Projects
- 291 • IC61: Comparative Effectiveness Research: A Conceptual Model in Wheelchair Service Provision
- 293 • IC62: Evaluation of Saddle Seating for Children with Special Needs
- 295 • IC63: Running a Seating Clinic 102: Going Beyond the Basics
- 297 • IC64: Colombian Wheelchair Sector: People, Policy, Products, and Provision
- 301 • PS8.1: System Requirements for Continuous Seat Pressure Mapping
- 305 • PS8.2: RCT on Wheeled Mobility for Pressure Injury Prevention
- 309 • PS8.3: Design and Verification of a Paediatric Wheelchair Cushion
- 313 • PS8.4: Simulating Terrain for Measuring Wheelchair Rolling Resistance
- 315 • **Saturday March 4, 2017**
- 317 • IC65: Maximizing Outcomes In Step with Advancing Technology
- 319 • IC66: Air Travel with a Wheelchair: What Seating Experts Should Know
- 321 • IC67: Solution to Complex Drive Systems with the ALS Population
- 323 • IC68: "Research & Evidence-Based Practice for Pressure Management and Tissue Integrity"
- 325 • IC69: Sip'n Puff: A Thing of the Past?
- 327 • IC70: Challenges and Solutions in Seating for Infants and Toddlers
- 329 • IC71: Creating Partnerships Among Clinicians and Engineering Programs
- 331 • IC72: Back to the "Ideal" Ultralight Manual Wheelchair
- 333 • PS9.1: Using Wearable Sensors to Track Upper Extremity Motion in Rehabilitation: A Literature Review
- 337 • PS9.2: Common Sense about Usable, Accessible, and Inclusive Public Seating
- 341 • PS9.3: Wheelchair Rugby Project: Academic and Clinical Collaboration
- 345 • PS9.4: Self-care Mobile Health Platform for Individuals with Spinal Cord Injury
- 347 • IC73: Custom Molding; Who, Why and How Tips from the Collaborative Team
- 349 • IC74: Providing Assistive Technology for the MS Client
- 351 • IC75: The Clinician Scientist: A Foundation for Leadership
- 353 • IC76: Training and Education for Novice Wheelchair Users
- 355 • IC77: Keep Calm and Evac On!
- 357 • IC78: Car Seats and Vehicular Transport for Children with Special Needs
- 359 • IC79: Assistive Technology Collaboration Between Occupational Therapists and Speech Language Pathologists in the Adult Rehabilitation Setting
- 361 • IC80: Expanding Roles of Therapist Assistants and Wheelchair Provision
- 365 • PS10.1: Changes in EEG Spectra in Response to Power Mobility Training

367 • PS10.2: Is Empowering Indoor/Outdoor Mobility

Medically Necessary?

371 • PS10.3: Parents' Perspectives of Infants Using Modified

Toy Cars

375 • PS10.4: Preliminary Design of Assistive Robotic Arm for

Kitchen Tasks

Faculty

A

Masayuki Abe, OT

Social Medical Corporation Hokuto, Tokachi Rehabilitation Center
Obihiro, Hokkaido
Japan
ot-abe@hokuto7.or.jp

PO1.3 | 3/2/2017 | 8:30AM

The Effect of Wheelchair Back Support Shape on Reach Accuracy

Jonathan Akins, PhD

jsakins@widner.edu

PS6.2 | 3/3/2017 | 1:30PM

An MRI Investigation Evaluating Tissue Response to Seat Cushions

Naomi Aldrich, PhD

Grand Valley State University
Allendale, Michigan
United States
aldrichn@gvsu.edu

PS10.1 | 3/4/2017 | 9:30AM

Changes in EEG Spectra in Response to Power Mobility Training

Ana Allegretti, PhD, OTR, ATP

University of Texas Health Sciences San Antonio
San Antonio, Texas
United States
allegrettial@uthscsa.edu

PC01 | 2/28/2017 | 8:00AM

Go Baby Go: An Innovative Method to Provide Mobility for Children

PO1.1 | 3/2/2017 | 8:30AM

Early Mobility Intervention: An Innate Right

PS7.2 | 3/3/2017 | 3:00PM

Proper Wheelchair Measurement and Fit

Claudia Amortegui, MBA

The Orion Consulting Group, Inc.
Denver, Colorado
United States
claudia@orionreimbursement.net

IC10 | 3/2/2017 | 2:30PM

What's the Latest: Medicare Documentation
& Coverage Requirements

B

Dan Bader, PhD, DSc

University of Southampton
Southampton
United Kingdom
D.L.Bader@soton.ac.uk

IC09 | 3/2/2017 | 2:30PM

Understanding Pressure Injuries for Effective Prevention

Erin Baker, PT, ATP, CPST

Nemours Children's Hospital
Orlando, Florida
United States
erin.baker@nemours.org

IC39 | 3/3/2017 | 11:00AM

Conquer the Complexity of Writing a Letter of Medical Necessity

IC78 | 3/4/2017 | 9:30AM

Car Seats and Vehicular Transport for Children with Special Needs

Valeria Baldassin, PT

SARAH Network of Rehabilitation Hospitals
Brasalia, DF
Brazil
204244@sarah.br

PS5.1 | 3/3/2017 | 11:00AM

Second Generation of a Low-Cost Smart Wheelchair

K. Missy Ball, MT, PT, ATP

PhysioBall Therapy LLC
Metairie, Louisiana
United States
missyballpt@aol.com

IC21 | 3/2/2017 | 4:00PM

The Past, Present and Future of Tilt & Recline

Patrick Barba, BSMeng

Letourneau University
Longview, Texas
United States
PatrickBarba@letu.edu

PS8.4 | 3/3/2017 | 4:30PM

Simulating Terrain for Measuring Wheelchair Rolling Resistance

Lelia Barks, PhD, ARNP

VA HSR&D Center of Innovation on Disability
and Rehabilitation Research
Tampa, Florida
United States
Lelia.Barks@va.gov

PS1.1 | 3/2/2017 | 1:00PM

Health Outcomes of Wheelchair Seated Posture in Older Veterans

PS1.2 | 3/2/2017 | 1:00PM

Developing a Seating Intervention for Older Veterans

Jill Barnett, BS

Magic Mobility
Noble Park, Victoria
Australia
jill@magicmobility.com.au

PS10.2 | 3/4/2017 | 9:30AM

Is Empowering Indoor/Outdoor Mobility Medically Necessary?

Carol Bartley, MSc, Pg, CAP, FHEA

University of Salford
Salford, Greater Manchester
United Kingdom
c.a.bartley@salford.ac.uk

PS6.4 | 3/3/2017 | 1:30PM

Factors Affecting Seating Prescription: An Evaluation of Watercell Technology in Complex Static Chairs

Sarah Bass

University of Pittsburgh, Human Engineering Research Laboratory
Pittsburgh, Pennsylvania
United States
srb94@pitt.edu

PS4.1 | 3/3/2017 | 9:30AM

Effects of Adjusting Wheelchair Configuration on Ramp Propulsion

PS4.4 | 3/3/2017 | 9:30AM

An Ergonomic Comparison of Three Different Seated Transport Devices

Amy Baxter, PT, DPT, ATP

Syracuse VAMC
Syracuse, New York
United States
amy.baxter@va.gov

IC31 | 3/3/2017 | 9:30AM

Meeting Lifetime Mobility Needs of Spinal Cord Injury and Disease

Michael Bender, OTR/L, ATP/SMS, CDRS

Therapeutic Specialties, Inc.
St. Louis, Missouri
United States
michaelbender@therapeuticspecialties.com

PS3.1 | 3/2/2017 | 4:00PM

Beyond Mobility: Above Knee Amputee Case Study

Alexandra Bennewith, MPA

United Spinal Association
Washington, DC
United States
ABennewith@unitedspinal.org

IC76 | 3/4/2017 | 9:30AM

Training and Education for Novice Wheelchair Users

Theresa Berner, MOT, OTR/L, ATP

Wexner Medical Center at The Ohio State University
Columbus, Ohio
United States
tfberner@gmail.com

PC04 | 3/1/2017 | 8:00AM

Shoulder Evaluation: An Evidence-Based Approach for Clinicians

IC57 | 3/3/2017 | 4:30PM

The Seating Clinic: Business Realities for Success

PS9.3 | 3/4/2017 | 8:00AM

Wheelchair Rugby Project: Academic and Clinical Collaboration

IC75 | 3/4/2017 | 9:30AM

The Clinician Scientist: A Foundation for Leadership

Jennith Bernstein, PT, DPT, ATP

Permobil, Inc.
Lebanon, Tennessee
United States
jennith.bernstein@permobil.com

IC11 | 3/2/2017 | 2:30PM

Optimizing the Ride: How Manual Wheelchair Configuration Enhances Function

Marianne Bertolet

marnie.bertolet@pitt.edu

PS8.2 | 3/3/2017 | 4:30PM

RCT on Wheeled Mobility for Pressure Injury Prevention

Chantal Berube, OT

Kinova Robotics
Boisbriand, Quebec
Canada
cberube@kinova.ca

IC24 | 3/2/2017 | 4:00PM

Advances in Upper Body Function; Here Come the Robots!

Kendra Betz, MSPT, ATP

Veterans Health Administration
Littleton, Colorado
United States
kendra.betz@comcast.net

PC03 | 2/28/2017 | 8:00AM

Set up for Success! Trials and Tribulations of Wheelchair Setup and Delivery

IC40 | 3/3/2017 | 11:00AM

New & Emerging Technologies: How to Ask the Right Questions When Evaluating Mobility Devices

IC51 | 3/3/2017 | 3:00PM

Advanced Mobility Skills Training for Manual Wheelchair Users

Marci Bienkowski, PT, DPT

Shriners Hospital for Children Philadelphia
Philadelphia, Pennsylvania
United States
mbienkowski@shrinenet.org

PO1.14 | 3/2/2017 | 8:30AM

Successful Outreach DME Program in Puerto Rico

Joyce Black, CWCN, FAAN

University of Nebraska Medical Center
Omaha, Nebraska
United States
jblack@unmc.edu

IC09 | 3/2/2017 | 2:30PM

Understanding Pressure Injuries for Effective Prevention

Sheila Blochlinger, PT, ATP

Children's Specialized Hospital
New Brunswick, New Jersey
United States
sblochlinger@childrens-specialized.org

PC02 | 2/28/2017 | 8:00AM

Foundations of Wheelchair Seating & Mobility Evaluations

Michael Boninger, MD

Human Engineering Research Lab
Pittsburgh, Pennsylvania
United States
boninger@upmc.edu

PO1.18 | 3/2/2017 | 8:30AM

Biomechanical Effects of Training on Wheelchair-Commode Transfers

PS4.3 | 3/3/2017 | 9:30AM

Wheelchair Breakdowns and Hospitalizations
in People with Spinal Cord Injury

Nathan Bray, PhD

Center for Health Economics and Medicines Evaluation
Gwynedd
United Kingdom
n.bray@bangor.ac.uk

IC61 | 3/3/2017 | 4:30PM

Comparative Effectiveness Research: A Conceptual
Model in Wheelchair Service Provision

David Brienza, PhD

University of Pittsburgh
Pittsburgh, Pennsylvania
United States
dbrienza@pitt.edu

IC09 | 3/2/2017 | 2:30PM

Understanding Pressure Injuries for Effective Prevention

PS6.2 | 3/3/2017 | 1:30PM

An MRI Investigation Evaluating Tissue Response to Seat Cushions

PS8.2 | 3/3/2017 | 4:30PM

RCT on Wheeled Mobility for Pressure Injury Prevention

Jeff Brown, ATP, CRTS

National Seating and Mobility
Easley, South Carolina
United States
jbrown@nsm-seating.com

IC63 | 3/3/2017 | 4:30PM

Running a Seating Clinic 102: Going Beyond the Basics

Lisa Brown, PhD

University of Palo Alto
Palo Alto, California
United States
lbrown@paloalto.edu

PS1.1 | 3/2/2017 | 1:00PM

Health Outcomes of Wheelchair Seated Posture in Older Veterans

Renee Brown, PT, PhD

Belmont University, Program in Physical Therapy
Nashville, Tennessee
United States
renee.brown@Belmont.edu

PS1.4 | 3/2/2017 | 1:00PM

Specialty Clinical Experience in Seating and Mobility

Melissa Bryan, OTD, OTR/L, ATP, CPST, CPAM

missy.g.bryan@gmail.com

PC01 | 2/28/2017 | 8:00AM

Go Baby Go: An Innovative Method to Provide Mobility for Children

Meredith Budai, DPT, ATP/SMS

International Center for Spinal Cord Injury
at Kennedy Krieger Institute
Baltimore, Maryland
United States
budai@kennedykrieger.org

IC47 | 3/3/2017 | 1:30PM

Solving Complex Seating Clinic Challenges in an Intense Climate

Mark Bulson, PT, MPT

Shriners Hospital for Children Philadelphia
Philadelphia, Pennsylvania
United States
mbulson@shrinenet.org

PO1.14 | 3/2/2017 | 8:30AM

Successful Outreach DME Program in Puerto Rico

Brian Burkhardt, MS, ATP

US Department of Veterans Affairs (Richmond)
Richmond, Pennsylvania
United States
Brian.Burkhardt@VA.gov

IC48 | 3/3/2017 | 1:30PM

Rehab Engineers + 3D Printing + Electronics = Personalized AT

A Yohali Burrola Mendez, MS, PT

University of Pittsburgh RST
Pittsburgh, Pennsylvania
United States
yohali.burrola@pitt.edu

PS5.4 | 3/3/2017 | 11:00AM

Evaluating the Effectiveness of Hybrid Wheelchair Training

C

Cathy Carver, PT, ATP/SMS

UAB/Spain Rehab Center
Hoover, Alabama
United States
cathyhcarver@gmail.com

PC09 | 3/1/2017 | 1:00PM

Power Assisted Technology: Evidenced Based Practice

IC18 | 3/2/2017 | 4:00PM

Updating Referral Sources on Medicare Wheelchair Requirements

Megan Case, CCC, SLP, ATP

Wexner Medical Center-Assistive Technology Center
Columbus, Ohio
United States
megan.case@osumc.edu

IC79 | 3/4/2017 | 9:30AM

Assistive Technology Collaboration Between Occupational Therapists and Speech Language Pathologists in Adult Rehab Setting

Katherine Clark, MOT, OTR/L, ATP

Cincinnati Children's Hospital Perlman Center
Cincinnati, Ohio
United States
katherine.eingle@cchmc.org

IC45 | 3/3/2017 | 1:30PM

Seeing Opportunities for Success: Visual Factors for Positioning

Donald Clayback

NCART
East Amherst, New York
United States
dclayback@ncart.us

IC02 | 3/2/2017 | 1:00PM

Complex Rehab Technology Update

Jim Closs, BS, BSc, KIN

Evac-Chair
Toronto, Ontario
Canada
jimcloss43@gmail.com

IC77 | 3/4/2017 | 9:30AM

Keep Calm and Evac On!

Laura Cohen, PT, PhD, ATP/SMS

Rehab & Tech Consultants, LLC
Arlington, Virginia
United States
Laura@rehabtechconsultants.com

PC06 | 3/1/2017 | 8:00AM

Coding and Reimbursement for a Successful Seating Clinic

IC18 | 3/2/2017 | 4:00PM

Updating Referral Sources on Medicare Wheelchair Requirements

Rory Cooper, PhD

University of Pittsburgh
Pittsburgh, Pennsylvania
United States
rcooper@pitt.edu

IC16 | 3/2/2017 | 2:30PM

Assistive Robotics to Support Activities of Daily Living

IC72 | 3/4/2017 | 8:00AM

Back to the "Ideal" Ultralight Manual Wheelchair

Rosemarie Cooper, MPT, ATP

University of Pittsburgh
Pittsburgh, Pennsylvania
United States
cooperrm@pitt.edu

IC72 | 3/4/2017 | 8:00AM

Back to the "Ideal" Ultralight Manual Wheelchair

Barbara Crane, PhD, PT, ATP/SMS

University of Hartford
Wethersfield, Connecticut
United States
bcrane@hartford.edu

PS1.1 | 3/2/2017 | 1:00PM

Health Outcomes of Wheelchair Seated Posture in Older Veterans

Barbara Crume, PT, ATP

CarePartners Health Services
Asheville, North Carolina
United States
Barbara.crume@msj.org

PC06 | 3/1/2017 | 8:00AM

Coding and Reimbursement for a Successful Seating Clinic

Theresa Crytzer, DPT, ATP

University of Pittsburgh
Pittsburgh, Pennsylvania
United States
theresapt00@yahoo.com

IC76 | 3/4/2017 | 9:30AM

Training and Education for Novice Wheelchair Users

D

Ashley Daff

Magic Mobility
Noble Park, Victoria
Australia
ashley@magicmobility.com.au

PS10.2 | 3/4/2017 | 9:30AM

Is Empowering Indoor/Outdoor Mobility Medically Necessary?

Genevieve Daoust, BSc, OT

Centre de Readaptation Marie Enfant, CHU Sainte-Justine
Montreal, Quebec
Canada
genevieve.daoust2@gmail.com

PS7.3 | 3/3/2017 | 3:00PM

Wheelchair Skills Training: University Course vs. Boot Camp

Brad Dicianno, MD

University of Pittsburgh Medical Center
Pittsburgh, Pennsylvania
United States
dicianno@pitt.edu

PS2.2 | 3/2/2017 | 2:30PM

Assessment of Seat Elevator User Satisfaction

Gerry Dickerson, ATP, CRTS

Medstar Surgical Inc.
College Point, New York
United States
gdcrts@aol.com

IC58 | 3/3/2017 | 4:30PM

A Memorial to our Colleagues Who Have Passed

John DiFrancesco

LeTourneau University
Longview, Texas
United States
johndifrancesco@letu.edu

PS7.1 | 3/3/2017 | 3:00PM

Interrater Reliability of the Wheelchair Components Questionnaire

Carmen DiGiovine, PhD, ATP/SMS, RET

The Ohio State University
Columbus, Ohio
United States
carmen.digiovine@osumc.edu

PC03 | 2/28/2017 | 8:00AM

Set up for Success! Trials and Tribulations
of Wheelchair Setup and Delivery

PC04 | 3/1/2017 | 8:00AM

Shoulder Evaluation: An Evidence-Based Approach for Clinicians

IC04 | 3/2/2017 | 1:00PM

Update on Functional Mobility Assessment and Uniform Data Set

IC60 | 3/3/2017 | 4:30PM

Ideas to Innovation: Student Design Projects and Capstone Projects

PS9.3 | 3/4/2017 | 8:00AM

Wheelchair Rugby Project: Academic and Clinical Collaboration

IC75 | 3/4/2017 | 9:30AM

The Clinician Scientist: A Foundation for Leadership

Dan Ding, PhD

University of Pittsburgh
Pittsburgh, Pennsylvania
United States
dad5@pitt.edu

IC16 | 3/2/2017 | 2:30PM

Assistive Robotics to Support Activities of Daily Living

PS9.1 | 3/4/2017 | 8:00AM

Using Wearable Sensors to Track Upper Extremity
Motion in Rehabilitation: A Literature Review

Devon Doebele, PTA

Max Mobility
Nashville, Tennessee
United States
devon@max-mobility.com

IC11 | 3/2/2017 | 2:30PM

Optimizing the Ride: How Manual Wheelchair
Configuration Enhances Function

John Doherty, OTR, ATP/SMS

Quantum Rehab
Exeter, Pennsylvania
United States
jdoherty@quantumrehab.com

IC19 | 3/2/2017 | 4:00PM

Environmental and Mobile Device Access for Power Wheelchair Users

E

Suzanne Eason, OT/L

St. Mary's Home
Norfolk, Virginia
United States
season@smhdc.org

PC07 | 3/1/2017 | 8:00AM

Dynamic Seating - Providing Movement and Why

Maria Eismann, BS, S/OT

The Ohio State University
Columbus, Ohio
United States
eismann.2@osu.edu

PS9.3 | 3/4/2017 | 8:00AM

Wheelchair Rugby Project: Academic and Clinical Collaboration

Catherine Ellens, BSc, OT

Sunny Hill Health Centre for Children
Vancouver, B.C.
Canada
cellens@cw.bc.ca

IC20 | 3/2/2017 | 4:00PM

Developing Competencies for Seating & Mobility Specialists

Lauren Esposito, PT, DPT

OhioHealth
Columbus, Ohio
United States
lauren.Esposito@Ohiohealth.com

IC74 | 3/4/2017 | 9:30AM

Providing Assistive Technology for the MS Client

F

Beth Farrell, PT, DPT, ATP/SMS

Kennedy Krieger Institute
Baltimore, Maryland
United States
farrelle@kennedykrieger.org

IC47 | 3/3/2017 | 1:30PM

Solving Complex Seating Clinic Challenges in an Intense Climate

John Farris, PhD

Grand Valley State University
Grand Rapids, Michigan
United States
farrisj@gvsu.edu

IC30 | 3/3/2017 | 9:30AM

Power Mobility for Children with Multiple Severe Disabilities

IC71 | 3/4/2017 | 8:00AM

Creating Partnerships Among Clinicians and Engineering Programs

PS10.1 | 3/4/2017 | 9:30AM

Changes in EEG Spectra in Response to Power Mobility Training

Dan Fedor

VGM / US Rehab
Waterloo, Iowa
United States
dan.fedor@vgm.com

IC34 | 3/3/2017 | 11:00AM

Mobility Addendums; Getting it Right the First Time

Heather Feldner, PT, PhD, PCS

University of Washington- Ability and Innovation Lab
Seattle, Washington
United States
hfeldner@uw.edu

IC06 | 3/2/2017 | 1:00PM

Go Baby Go? Stakeholder Perceptions of Powered Mobility Provision

IC38 | 3/3/2017 | 11:00AM

Driving for Change: Ending Barriers and Paving the Way for Play

Debra Field, OT, PhD

University of British Columbia
Vancouver, British Columbia
Canada
debrafield@hotmail.com

IC12 | 3/2/2017 | 2:30PM

Powered Wheelchair Provision: Current Practices and Opportunities

Laura Finney, PhD, MSc, BEng, CEng

James Leckey Design
Lisburn, Antrim
United Kingdom
laura.finney@leckey.com

IC14 | 3/2/2017 | 2:30PM

Understanding Pediatric Mobility Needs from Parental Perspective

PS8.3 | 3/3/2017 | 4:30PM

Design and Verification of a Pediatric Wheelchair Cushion

Kathryn Fisher, BSc, OT

Private Practice Rehab Equipment Consultant/Clinical Educator
Toronto, Ontario
Canada
kfish@rogers.com

PC11 | 3/1/2017 | 1:00PM

Choosing the Right Sling and Lift for the Right Wheelchair

IC77 | 3/4/2017 | 9:30AM

Keep Calm and Evac On!

Jane Fontein, OT

Consultant Dynamic Health Care Solutions and Motion Composites
Vancouver, British Columbia
Canada
janefontein@gmail.com

PC03 | 2/28/2017 | 8:00AM

Set up for Success! Trials and Tribulations of Wheelchair Setup and Delivery

IC03 | 3/2/2017 | 1:00PM

What's in a Back?

Molly Fugate, PT, DPT

Cincinnati Children's Hospital Medical Center - Perlman Center
Cincinnati, Ohio
United States
molly.fugate@cchmc.org

PO1.5 | 3/2/2017 | 8:30AM

Firefly Products Used for Functional Play & ADLs in Kids with CP

Karen H. Fung, MSc

Universite de Montreal
Montreal, Quebec
Canada
karen.fung@umontreal.ca

PS5.2 | 3/3/2017 | 11:00AM

A Global Description of Wheelchair Service Education

G

Julie Gaby, MPA, OTR/L, ATP, CAPS

Orlando Health
Orlando, Florida
United States
julie.gaby@orlandohealth.com

IC05 | 3/2/2017 | 1:00PM

The Integration of Wheelchair Mobility and Home Accessibility

Cole Galloway, PT, PhD

University of Delaware
Newark, Delaware
United States
jacgallo@udel.edu

PC01 | 2/28/2017 | 8:00AM

Go Baby Go: An Innovative Method to Provide Mobility for Children

IC06 | 3/2/2017 | 1:00PM

Go Baby Go? Stakeholder Perceptions of Powered Mobility Provision

Rachel Gartz, BSc
University of Pittsburgh
Pittsburgh, Pennsylvania
United States
reg41@pitt.edu

PS5.2 | 3/3/2017 | 11:00AM

A Global Description of Wheelchair Service Education

Cynthia Garvan, PhD

VA, University of Florida
Gainesville, Florida
United States
cgarvan@ufl.edu

PS1.1 | 3/2/2017 | 1:00PM

Health Outcomes of Wheelchair Seated Posture in Older Veterans

Tricia Garven, PT, ATP

Permobil
Lebanon, Tennessee
United States
tricia.garven@permobil.com

IC35 | 3/3/2017 | 11:00AM

Are Environmental Control Units (ECUs) a Thing of the Past?

Amit Gefen, PhD

Tel Aviv University
Tel Aviv, Israel
gefen@eng.tau.ac.il

IC09 | 3/2/2017 | 2:30PM

Understanding Pressure Injuries for Effective Prevention

PS6.1 | 3/3/2017 | 1:30PM

Modeling Pressure Injury Conditions Caused by Toilet Seats

PS6.2 | 3/3/2017 | 1:30PM

An MRI Investigation Evaluating Tissue Response to Seat Cushions

PS6.3 | 3/3/2017 | 1:30PM

How a Cushion Can Effectively Protect Against Pressure Injury

Pam Glazener, OTR, ATP

Houston Methodist Hospital
Houston, Texas
United States
pglazener@houstonmethodist.org

IC67 | 3/4/2017 | 8:00AM

Solution to Complex Drive Systems with the ALS Population

Amy Godinez

LeTourneau University
Longview, Texas
United States
amygodinez@letu.edu

PS7.4 | 3/3/2017 | 3:00PM

Reliability of the Aspects of Wheelchair Mobility Protocol

Mary Goldberg, PhD

University of Pittsburgh
Pittsburgh, Pennsylvania
United States
mrh35@pitt.edu

PS5.2 | 3/3/2017 | 11:00AM

A Global Description of Wheelchair Service Education

IC60 | 3/3/2017 | 4:30PM

Ideas to Innovation: Student Design Projects and Capstone Projects

IC28 | 3/3/2017 | 9:30AM

How Do We Learn the Skills to Become Seating Therapists?

Carlos Goncalves, MEng

Sarah Network of Hospitals in Rehabilitation
Brasalia, Distrito Federal
Brazil
cwpg@sarah.br

PS5.1 | 3/3/2017 | 11:00AM

Second Generation of a Low-Cost Smart Wheelchair

William Gouvea Dias

Industrial Designer
SARAH Network of Rehabilitation Hospitals
Brasalia, DF
Brazil
300426@sarah.br

PS5.1 | 3/3/2017 | 11:00AM

Second Generation of a Low-Cost Smart Wheelchair

Amy Grace, OTR/L

The Ohio State University Medical Ctr.
Galloway, Ohio
United States
amy.grace@osumc.edu

IC79 | 3/4/2017 | 9:30AM

Assistive Technology Collaboration Between Occupational Therapists and Speech Language Pathologists in Adult Rehab Setting

Elizabeth Green, OTR/L, CDRS, CAE

ADED
Hickory, North Carolina
United States
Elizabeth.green@driver-ed.org

PC10 | 3/1/2017 | 1:00PM

Vehicles and Modifications: Considerations for the AT Team

Jonathan Greenwood, PT, MS, c/NDT, CEIS, DPT, PCS

Boston Children's Hospital
Boston, Massachusetts
United States
jonathan.greenwood@childrens.harvard.edu

IC23 | 3/2/2017 | 4:00PM

A Lifespan Blueprint for DME: Cerebral Palsy

Jefferson Griscavage

Human Engineering Research Laboratories
Pittsburgh, Pennsylvania
United States
jsg56@pitt.edu

PS4.4 | 3/3/2017 | 9:30AM

An Ergonomic Comparison of Three Different Seated Transport Devices

H

Elaina Halkiotis, MOT, OTR/L, ATP

Independence Care System
Brooklyn, New York
United States
ehalkiotis@icsny.org

IC55 | 3/3/2017 | 3:00PM

Adaptive Bathroom Equipment for Adults

Jacqueline Hall, MS, OTR/L ATP

VA Puget Sound Health Care System
Seattle, Washington
United States
Jacqueline.Hall2@va.gov

PO1.11 | 3/2/2017 | 8:30AM

Live Measurement Versus Photogrammetry for Seating Assessments

Dawn Hameline, OTR/L, ATP

University of Vermont Medical Center
Shelburne, Vermont
United States
Dj.hameline@gmail.com

IC41 | 3/3/2017 | 1:30PM

CARF Accreditation in Assistive Technology

Darren Hammond, MPT, PT, CWS

ROHO Institute
Belleville, Illinois
United States
darren.hammond@permobil.com

PC13 | 3/1/2017 | 8:00AM

Pressure Injury Management for Rehabilitation Professionals

IC01 | 3/2/2017 | 1:00PM

Using the Science of Materials to Compare Wheelchair Cushions

Michelle Harvey, OT

HME
North Vancouver, British Columbia
Canada
michelleharveyot@gmail.com

PC11 | 3/1/2017 | 1:00PM

Choosing the Right Sling and Lift for the Right Wheelchair

Tatsuo Hatta, OT

Faculty of Health Sciences, Nihonryyo University
Eniwa, Hokkaido
Japan
thatta@nihoniryoyo-c.ac.jp

PO1.3 | 3/2/2017 | 8:30AM

The Effect of Wheelchair Back Support Shape on Reach Accuracy

Geoffrey Henderson, MD

University of Pittsburgh Medical Center
Pittsburgh, Pennsylvania
United States
hendersongv@upmc.edu

PS2.2 | 3/2/2017 | 2:30PM

Assessment of Seat Elevator User Satisfaction

Janice Herman, PT

Adapt Shop at Southwest Human Development
Phoenix, Arizona
United States
jherman@swhd.org

IC70 | 3/4/2017 | 8:00AM

Challenges and Solutions in Seating for Infants and Toddlers

Azalya Hernandez, MOTS, CBIS

University of Texas Health Science Center at San Antonio
San Antonio, Texas
United States
Hernandezav@livemail.uthscsa.edu

PO1.1 | 3/2/2017 | 8:30AM

Early Mobility Intervention: An Innate Right

Gary Herrero, PT

VA Puget Sound Health Care System
Seattle, Washington
United States
Gary.Herrero@va.gov

PO1.11 | 3/2/2017 | 8:30AM

Live Measurement Versus Photogrammetry for Seating Assessments

Todd Hertenstein, ATP

Gillette Children's Specialty Healthcare
St. Paul, Minnesota
United States
THertenstein@gillettechildrens.com

PC08 | 3/1/2017 | 1:00PM

The Wheelchair Clinic Experience: Effective, Efficient, Empowering

Thomas Hetzel, PT, ATP

Ride Designs
Littleton, Colorado
United States
tom@ridedesigns.com

IC17 | 3/2/2017 | 4:00PM

Early vs. Late Intervention with Custom Molded Seating

IC54 | 3/3/2017 | 3:00PM

To Abduct or Not Abduct: That is the Question

Rachel Hibbs, PT, DPT, PA

University of Pittsburgh Medical Center
Pittsburgh, Pennsylvania
United States
hibbsr@upmc.edu

IC36 | 3/3/2017 | 11:00AM

Group Wheelchair Skills Training- Setting and Achieving Goals

Corey Hickey, DO

University of Pittsburgh Medical Center
Pittsburgh, Pennsylvania
United States
hickeycw@upmc.edu

PS2.2 | 3/2/2017 | 2:30PM

Assessment of Seat Elevator User Satisfaction

Bjarte Hjorthaug, BH
Nav Assistive Technology
Skedsmokorset, 2020
Norway
bjarte.hjorthaug@gmail.com

PO1.6 | 3/2/2017 | 8:30AM
We Give People Possibilities; Special Adaptations for Activity

Nathan Hogaboom, BS
Human Engineering Research Laboratories, University of Pittsburgh
Pittsburgh, Pennsylvania
United States
nsh15@pitt.edu

PS4.3 | 3/3/2017 | 9:30AM
Wheelchair Breakdowns and Hospitalizations
in People with Spinal Cord Injury

Elisa Hopwood, OTL
Santa Clara Valley Medical Center
San Jose, California
United States
Elisa.Hopwood@hhs.sccgov.org

IC35 | 3/3/2017 | 11:00AM
Are Environmental Control Units (ECUs) a Thing of the Past?

Ileana Howard, MD
VA Puget Sound Health Care System
Seattle, Washington
United States
Ileana.Howard@va.gov

PO1.11 | 3/2/2017 | 8:30AM
Live Measurement Versus Photogrammetry for Seating Assessments

Sheila Howes-Trammel, MSN, APRN, FNP-BC
Hennepin County Medical Center
Minneapolis, Minnesota
United States
howes.sheila@gmail.com

PO1.8 | 3/2/2017 | 8:30AM
Using Friction Management to Prevent and Treat Pressure Injuries

PO1.9 | 3/2/2017 | 8:30AM
IAD: Can Reducing Friction and Shear Heal and Prevent Recurrence?

Lee Ann Hoffman, OT, MS
Invacare
Grand Prairie, Texas
United States
lehoffman@invacare.com

PC15 | 3/1/2017 | 8:00AM
Postural Care: Supporting People Night and Day

Kara Huff
LeTourneau University
Longview, Texas
United States
karadaniellehuff@letu.edu

PS7.4 | 3/3/2017 | 3:00PM
Reliability of the Aspects of Wheelchair Mobility Protocol

Alli Hyde, MS, OT
Motion Composites
Sait-Roch-de-l'Achigan, Quebec
Canada
a.hyde@motioncomposites.com

PC03 | 2/28/2017 | 8:00AM
Set up for Success! Trials and Tribulations
of Wheelchair Setup and Delivery

IC03 | 3/2/2017 | 1:00PM
What's in a Back?

Maighread Ireland, MEng
Royal Liverpool University Hospital
Liverpool, Merseyside
United Kingdom
maighread.ireland@nhs.net

PS8.3 | 3/3/2017 | 4:30PM
Design and Verification of a Pediatric Wheelchair Cushion

Molly Jeffers, BS
Human Engineering Research Laboratories
Pittsburgh, Pennsylvania
United States
mkjeffer@ncsu.edu

PS10.4 | 3/4/2017 | 9:30AM
Preliminary Design of Assistive Robotic Arm for Kitchen Tasks

Wolff Jennifer, OT
United Spinal Association
Washington, DC
United States
jwolff@unitedspinal.org

IC76 | 3/4/2017 | 9:30AM
Training and Education for Novice Wheelchair Users

Deepan Kamaraj, MD
University of Pittsburgh
Pittsburgh, Pennsylvania
United States
dck20@pitt.edu

IC61 | 3/3/2017 | 4:30PM
Comparative Effectiveness Research: A Conceptual
Model in Wheelchair Service Provision

Karen Kangas, OTR/L

Private Practice
Camp Hill, Pennsylvania
United States
kmkangas@ptd.net

PC14 | 3/1/2017 | 8:00AM

Powered Mobility Training for First Time Users

IC59 | 3/3/2017 | 4:30PM

Integration of Powered Mobility, AAC, & Computers

Patricia Karg, MSE

University of Pittsburgh
Pittsburgh, Pennsylvania
United States
tkarg@pitt.edu

PS6.2 | 3/3/2017 | 1:30PM

An MRI Investigation Evaluating Tissue Response to Seat Cushions

PS8.2 | 3/3/2017 | 4:30PM

RCT on Wheeled Mobility for Pressure Injury Prevention

Lisa Kenyon, PT, DPT, PhD, PCS

Grand Valley State University
Grand Rapids, Michigan
United States
kenyonli@gvsu.edu

IC12 | 3/2/2017 | 2:30PM

Powered Wheelchair Provision: Current Practices and Opportunities

IC44 | 3/3/2017 | 1:30PM

Empowering Practice: Evaluating Seating and Mobility Outcomes

IC30 | 3/3/2017 | 9:30AM

Power Mobility for Children with Multiple Severe Disabilities

IC71 | 3/4/2017 | 8:00AM

Creating Partnerships Among Clinicians and Engineering Programs

PS10.1 | 3/4/2017 | 9:30AM

Changes in EEG Spectra in Response to Power Mobility Training

Angie Kiger, MEd, CTRS, ATP/SMS

Sunrise Medical
Boulder, Colorado
United States
angie.kiger@sunmed.com

IC46 | 3/3/2017 | 1:30PM

Assessing Mobility for Those with Cortical Visual Impairment

IC37 | 3/3/2017 | 11:00AM

School of Power Mobility: Tips for Teaching Power Mobility Skills

Martin Kilbane, PT, OCS

Louis Stokes Cleveland VA Medical Center
Rocky River, Ohio
United States
martin_kilbane@yahoo.com

PC04 | 3/1/2017 | 8:00AM

Shoulder Evaluation: An Evidence-Based Approach for Clinicians

Hirotohi Kishigami, OT

Faculty of Health Sciences, Hokkaido University
Sapporo, Hokkaido
Japan
kishi@med.hokudai.ac.jp

PO1.3 | 3/2/2017 | 8:30AM

The Effect of Wheelchair Back Support Shape on Reach Accuracy

Tamara Kittelson-Aldred, MS, OTR/L, ATP/SMS

Posture 24/7
Missoula, Montana
United States
tamara@posture24-7.org

PC15 | 3/1/2017 | 8:00AM

Postural Care: Supporting People Night and Day

PO1.15 | 3/2/2017 | 8:30AM

Eleanore's Project: Wheelchairs and 24-Hour Postural Care in Peru

PS4.2 | 3/3/2017 | 9:30AM

Montana Postural Care Project: A 24-Hour Postural Care Model

Joseph W. Klaesner, PhD

Washington University
St. Louis, Missouri
United States
klaesnerjw@wustl.edu

PS3.4 | 3/2/2017 | 4:00PM

Motor Learning Approach for Training Manual Wheelchair Users

Wendy Koesters, PT, ATP/SMS

OSMC
Columbus, Ohio
United States
wendy.koesters@osumc.edu

PC04 | 3/1/2017 | 8:00AM

Shoulder Evaluation: An Evidence-Based Approach for Clinicians

IC65 | 3/4/2017 | 8:00AM

Maximizing Outcomes in Step with Advancing Technology

PS9.3 | 3/4/2017 | 8:00AM

Wheelchair Rugby Project: Academic and Clinical Collaboration

Alicia Koontz, PhD, RET, ATP

Human Engineering Research Laboratories
Pittsburgh, Pennsylvania
United States
akoontz@pitt.edu

PS2.3 | 3/2/2017 | 2:30PM

Evaluating Wheelchair Transfer Technique by Microsoft Kinect

PO1.18 | 3/2/2017 | 8:30AM

Biomechanical Effects of Training on Wheelchair-Commode Transfers

PS4.1 | 3/3/2017 | 9:30AM

Effects of Adjusting Wheelchair Configuration on Ramp Propulsion

PS4.4 | 3/3/2017 | 9:30AM

An Ergonomic Comparison of Three Different Seated Transport Devices

Kara Kopplin

Senior Director, Efficacy and Research
ROHO Inc.
Belleville, Illinois
United States
Kara.Kopplin@permobil.com

PS6.1 | 3/3/2017 | 1:30PM

Modeling Pressure Injury Conditions Caused by Toilet Seats

PS6.2 | 3/3/2017 | 1:30PM

An MRI Investigation Evaluating Tissue Response to Seat Cushions

PS6.3 | 3/3/2017 | 1:30PM

How a Cushion Can Effectively Protect Against Pressure Injury

Carlos Kramer

Vicair
Wormer, Netherlands
c.kramer@vicair.com

IC33 | 3/3/2017 | 11:00AM

Introduction of the Total Shear Measurement Device, iShear

David Kreutz, PT, ATP

Shepherd Center
Atlanta, Georgia
United States
djkreutz148@gmail.com

IC69 | 3/4/2017 | 8:00AM

Sip'n Puff: A Thing of the Past?

Christin Krey, PT, MPT

Shriners Hospital for Children- Philadelphia
Philadelphia, Pennsylvania
United States
ckrey@shrinenet.org

PO1.14 | 3/2/2017 | 8:30AM

Successful Outreach DME Program in Puerto Rico

L**Nicole LaBerge, PT, ATP**

Hennepin County Medical Center
Minneapolis, Minnesota
United States
Nicole.laberge@hcmcd.org

PC08 | 3/1/2017 | 1:00PM

The Wheelchair Clinic Experience: Effective, Efficient, Empowering

Amy Lane, OTR/L, CDRS

University of Pittsburgh
Pittsburgh, Pennsylvania
United States
akl7@pitt.edu

PC10 | 3/1/2017 | 1:00PM

Vehicles and Modifications: Considerations for the AT Team

Leisa Lang, ATP, COTA

Reliable Medical
Brooklyn Park, Minnesota
United States
lalang@reliamed.com

PO1.7 | 3/2/2017 | 8:30AM

Innovative New Custom Seat Design; Clinical Case Examples

Michelle Lange, OTR/L, ABDA, ATP/SMS

Access to Independence
Arvada, Colorado
United States
MichelleLange@msn.com

PC07 | 3/1/2017 | 8:00AM

Dynamic Seating - Providing Movement and Why

IC27 | 3/3/2017 | 9:30AM

Positioning the Head

Stefanie Laurence, BSc, OT

Motion Specialties
Toronto, Ontario
Canada
slaurence@motionspecialties.com

IC53 | 3/3/2017 | 3:00PM

Seating the 'Unseatable'

Jenny Lieberman, PhD, OTR/L, ATP

Mount Sinai Hospital
New York, New York
United States
Jenny.Lieberman@mountsinai.org

PS1.3 | 3/2/2017 | 1:00PM

The Experience of Spinal Cord Injury and Wheelchair Use

Jason Lind, PhD

VA
Tampa, Florida
United States
Jason.Lind@va.gov

PS1.2 | 3/2/2017 | 1:00PM

Developing a Seating Intervention for Older Veterans

Hsin-Yi Liu, PhD, PT

University of Pittsburgh
Pittsburgh, Pennsylvania
United States
hsl16@pitt.edu

IC76 | 3/4/2017 | 9:30AM

Training and Education for Novice Wheelchair Users

Maayan Lustig

Department of Biomedical Engineering, Tel Aviv University
Tel Aviv, Israel
maay7@mail.tau.ac.il

PS6.1 | 3/3/2017 | 1:30PM

Modeling Pressure Injury Conditions Caused by Toilet Seats

M

Hiroki Mani, PT

Faculty of Health Sciences, Hokkaido University
Sapporo, Hokkaido
Japan
h-mani.0620@hs.hokudai.ac.jp

PO1.3 | 3/2/2017 | 8:30AM

The Effect of Wheelchair Back Support Shape on Reach Accuracy

Chris Maurer, MPT, ATP

Shepherd Center Seating and Mobility Clinic
Atlanta, Georgia
United States
chris.maurer@shepherd.org

IC42 | 3/3/2017 | 1:30PM

Documentation for Complex Rehab Technology: The Ethical Dilemma

IC69 | 3/4/2017 | 8:00AM

Sip'n Puff: A Thing of the Past?

Bryan McCormick

Office of Vocational Rehabilitation
Pittsburgh, Pennsylvania
United States
brymccormi@pa.gov

IC72 | 3/4/2017 | 8:00AM

Back to the "Ideal" Ultralight Manual Wheelchair

Lynore McLean, PT

Sunny Hill
Vancouver, British Columbia
Canada
lmclean3@cw.bc.ca

IC54 | 3/3/2017 | 3:00PM

To Abduct or Not Abduct: That is the Question

Sheila McNeill, BSc Hons, MSCP

Leckey
Belfast
United Kingdom
Sheila.mcneill13@gmail.com

IC14 | 3/2/2017 | 2:30PM

Understanding Pediatric Mobility Needs from Parental Perspective

Anand Mhatre, MIMSE

International Society of Wheelchair Professionals
Pittsburgh, Pennsylvania
United States
aam108@pitt.edu

IC08 | 3/2/2017 | 1:00PM

Development of Wheelchair Standards for Less-Resourced Settings

PS5.3 | 3/3/2017 | 11:00AM

Development of an Online Wheelchair List for Wheelchair Users

Sandra Anstaett Metzler, DSc, PE

The Ohio State University
Columbus, Ohio
United States
metzler.136@osu.edu

IC60 | 3/3/2017 | 4:30PM

Ideas to Innovation: Student Design Projects and Capstone Projects

Rachel Arata-Maiers, OTS

University of Texas Health Science Center San Antonio
San Antonio, Texas
United States
aratamaiers@livemail.uthscsa.edu

PS7.2 | 3/3/2017 | 3:00PM

Proper Wheelchair Measurement and Fit

Erin Michael, PT, DPT, ATP/SMS

ICSCI at KKI
Baltimore, Maryland
United States
michaele@kennedykrieger.org

IC47 | 3/3/2017 | 1:30PM

Solving Complex Seating Clinic Challenges in an Intense Climate

William Miller, PhD, FCAOT

University of British Columbia
Vancouver, British Columbia
Canada
bill.miller@ubc.ca

IC12 | 3/2/2017 | 2:30PM

Powered Wheelchair Provision: Current Practices and Opportunities

IC44 | 3/3/2017 | 1:30PM

Empowering Practice: Evaluating Seating and Mobility Outcomes

Steven Mitchell, OTR/L, ATP

Cleveland VA Medical Center SCI/D
Cleveland, Ohio
United States
stevemitchell@ameritech.net

IC32 | 3/3/2017 | 9:30AM

An Introduction to Hybrid Alternative Driving Systems

Brenlee Mogul-Rotman, OT

Permobil Canada
Aurora, Ontario
Canada
brenleemogul@rogers.com

IC53 | 3/3/2017 | 3:00PM

Seating the 'Unseatable'

IC68 | 3/4/2017 | 8:00AM

Research & Evidence-Based Practice for Pressure Management and Tissue Integrity

Rhona Moot, BSc, OT

Invacare
Ede, Gelderland
Netherlands
rmoot@invacare.com

IC28 | 3/3/2017 | 9:30AM

How Do We Learn the Skills to Become Seating Therapists?

Amy Morgan, PT, ATP

Permobil, Inc.
Mason, Ohio
United States
amy.morgan@permobil.com

IC65 | 3/4/2017 | 8:00AM

Maximizing Outcomes in Step with Advancing Technology

Kerri Morgan, PhD, OTR/L, ATP

Washington University
St. Louis, Missouri
United States
morgank@wustl.edu

PS3.4 | 3/2/2017 | 4:00PM

Motor Learning Approach for Training Manual Wheelchair Users

Danielle Morris, PT, DPT, PCS, C/NDT, CPST

OloI
Baton Rouge, Louisiana
United States
daniellemorrispt@yahoo.com

PC05 | 3/1/2017 | 8:01AM

Empowering Individuals to Ensure Safe Wheelchair Transportation

Melissa Morrow, PhD

Mayo Clinic
Rochester, Minnesota
United States
morrow.melissa@mayo.edu

PS8.1 | 3/3/2017 | 4:30PM

System Requirements for Continuous Seat Pressure Mapping

Stacey Mullis, OTR/L, ATP

Comfort Company
Charlotte, North Carolina
United States
stacey.mullis@comfortcompany.com

IC52 | 3/3/2017 | 3:00PM

Meeting the Unmet Need: Encouraging and Educating Therapists

Sara Munera, BS

University of Pittsburgh
Pittsburgh, Pennsylvania
United States
sam320@pitt.edu

IC56 | 3/3/2017 | 3:00PM

An Online Wheelchair Maintenance Training Program for Clinicians

IC64 | 3/3/2017 | 4:30PM

Colombian Wheelchair Sector: People,
Policy, Products, and Provision

Sarah Murdoch, PT, DPT, ATP

ICSCI at KKI
Baltimore, Maryland
United States
Murdoch@kennedykrieger.org

IC47 | 3/3/2017 | 1:30PM

Solving Complex Seating Clinic Challenges in an Intense Climate

Kara Murphy, MS, OTR/L

Syracuse VA Medical Center
Syracuse, New York
United States
karaot74@hotmail.com

IC31 | 3/3/2017 | 9:30AM

Meeting Lifetime Mobility Needs of Spinal Cord Injury and Disease

O**Melissa Oliver, MS, OTR/L**

McGuire VA Medical Center
Richmond, Virginia
United States
Melissa.Oliver@va.gov

IC41 | 3/3/2017 | 1:30PM

CARF Accreditation in Assistive Technology

Cees Oomens, PhD

Eindhoven University of Technology
Eindhoven,
The Netherlands
C.W.J.Oomens@tue.nl

IC09 | 3/2/2017 | 2:30PM

Understanding Pressure Injuries for Effective Prevention

P**Greg Packer**

US Rehab
Waterloo, Iowa
United States
Greg.Packer@usrehab.com

IC04 | 3/2/2017 | 1:00PM

Update on Functional Mobility Assessment and Uniform Data Set

Ginny Paleg, DScPT, MPT, PT

Montgomery County Schools
Silver Spring, Maryland
United States
ginny@paleg.com

IC54 | 3/3/2017 | 3:00PM

To Abduct or Not Abduct: That is the Question

Mark Partridge, RRTS

Numotion
Atlanta, Georgia
United States
Mark.partridge@numotion.com

IC69 | 3/4/2017 | 8:00AM

Sip'n Puff: A Thing of the Past?

Mark Payette, CO, ATP

Tamarack Habilitation Technologies, Inc.
Blaine, Minnesota
United States
markp@tamarackhti.com

PO1.7 | 3/2/2017 | 8:30AM

Innovative New Custom Seat Design; Clinical Case Examples

PO1.8 | 3/2/2017 | 8:30AM

Using Friction Management to Prevent and Treat Pressure Injuries

PO1.9 | 3/2/2017 | 8:30AM

IAD: Can Reducing Friction and Shear Heal and Prevent Recurrence?

Jonathan Pearlman, PhD

University of Pittsburgh/ISWP
Pittsburgh, Pennsylvania
United States
jlp46@pitt.edu

IC08 | 3/2/2017 | 1:00PM

Development of Wheelchair Standards for Less-Resourced Settings

PS5.2 | 3/3/2017 | 11:00AM

A Global Description of Wheelchair Service Education

IC56 | 3/3/2017 | 3:00PM

An Online Wheelchair Maintenance Training Program for Clinicians

IC64 | 3/3/2017 | 4:30PM

Colombian Wheelchair Sector: People,
Policy, Products, and Provision

Greg Peek

Seating Dynamics - Owner
Englewood, Colorado
United States
greg.peek@atrmfg

IC21 | 3/2/2017 | 4:00PM

The Past, Present and Future of Tilt & Recline

Randy Pesich, ATP

Permobil
Virginia Beach, Virginia
United States
randy.pesich@permobil.com

PS3.2 | 3/2/2017 | 4:00PM

Advocating Necessity for Bluetooth Power Mobility Integration

Naomi Petersen, EdD

Central Washington University
Ellensburg, Washington
United States
NJP@cwu.edu

PS9.2 | 3/4/2017 | 8:00AM

Common Sense about Usable, Accessible, and Inclusive Seating

Cindi Petito, OTR/L, ATP, CAPS

CHAS Group HC Corp
Middleburg, Florida
United States
Cindi.petito@chasgp.com

IC15 | 3/2/2017 | 2:30PM

Managing Posture using Adjustable Micro Modular Seating (AMMS)

IC46 | 3/3/2017 | 1:30PM

Assessing Mobility for Those with Cortical Visual Impairment

Julie Piriano, PT, ATP/SMS

Pride Mobility Products Corp./Quantum Rehab
Exeter, Pennsylvania
United States
jpiriano@quantumrehab.com

IC50 | 3/3/2017 | 3:00PM

Power Adjustable Seat Height is Both Reasonable and Necessary!

Teresa Plummer, PhD, OTR/L, CAPS, CEAS, ATP

Belmont University
Nashville, Tennessee
United States
teresa.plummer@belmont.edu

PC01 | 2/28/2017 | 8:00AM

Go Baby Go: An Innovative Method to Provide Mobility for Children

Perna Poojary-Mazzotta, MS

University of Pittsburgh
Pittsburgh, Pennsylvania
United States
prp19@pitt.edu

PS8.2 | 3/3/2017 | 4:30PM

RCT on Wheeled Mobility for Pressure Injury Prevention

Erin Pope, PT, MPT, ATP

Cincinnati Children's Hospital Perlman Center
Cincinnati, Ohio
United States
erin.pope@cchmc.org

IC45 | 3/3/2017 | 1:30PM

Seeing Opportunities for Success: Visual Factors for Positioning

IC54 | 3/3/2017 | 3:00PM

To Abduct or Not Abduct: That is the Question

Ronald Porter, OTR

AOTA, Wickenburg Community Hospital
Wickenburg, Arizona
United States
ronald.porter@wickhosp.com

PS10.2 | 3/4/2017 | 9:30AM

Is Empowering Indoor/Outdoor Mobility Medically Necessary?

Caroline Portoghese, OTR/L, ATP

University of Minnesota Medical Center - Fairview
Saint Paul, Minnesota
United States
carolineandsteve@aol.com

PO1.9 | 3/2/2017 | 8:30AM

IAD: Can Reducing Friction and Shear Heal and Prevent Recurrence?

Gail Powell-Cope, PhD, ARNP, FAAN

VA CINDRR
Tampa, Florida
United States
Gail.Powell-Cope@va.gov

PS1.1 | 3/2/2017 | 1:00PM

Health Outcomes of Wheelchair Seated Posture in Older Veterans

PS1.2 | 3/2/2017 | 1:00PM

Developing a Seating Intervention for Older Veterans

Penny Powers, PT, MS, ATP

Vanderbilt Medical Center - Pi Beta Phi Rehabilitation Institute
Nashville, Tennessee
United States
penny.powers@vanderbilt.edu

PC09 | 3/1/2017 | 1:00PM

Power Assisted Technology: Evidenced Based Practice

PS1.4 | 3/2/2017 | 1:00PM

Specialty Clinical Experience in Seating and Mobility

Jessica Presperin Pedersen, OTR/L, ATP

Rehab Institute of Chicago
Chicago, Illinois
United States
jesspeders@gmail.com

PC07 | 3/1/2017 | 8:00AM

Dynamic Seating - Providing Movement and Why

IC36 | 3/3/2017 | 11:00AM

Group Wheelchair Skills Training- Setting and Achieving Goals

IC26 | 3/3/2017 | 9:30AM

Rehab on the Ropes: Round 2 of the CMS Competitive Bid Program

IC66 | 3/4/2017 | 8:00AM

Air Travel with a Wheelchair: What Seating Experts Should Know

Deborah Pucci, PT, MPT

Rehabilitation Institute of Chicago
Chicago, Illinois
United States
dpucci@ric.org

IC26 | 3/3/2017 | 9:30AM

Rehab on the Ropes: Round 2 of the CMS Competitive Bid Program

Jack R. Engsberg, PhD

Washington University
St. Louis, Missouri
United States
engsbergj@wustl.edu

PS3.4 | 3/2/2017 | 4:00PM

Motor Learning Approach for Training Manual Wheelchair Users

R**Leena Rapacz, PT, DPT**

Courage Kenny Rehabilitation Institute
Golden Valley, Minnesota
United States
Leena.Rapacz@allina.com

PC08 | 3/1/2017 | 1:00PM

The Wheelchair Clinic Experience: Effective, Efficient, Empowering

Norman Reese

LeTourneau University
Longview, Texas
United States
NormanReese@letu.edu

PS8.4 | 3/3/2017 | 4:30PM

Simulating Terrain for Measuring Wheelchair Rolling Resistance

Emma Regan, BSc, OT

Belfast Health & Social Care Trust, Northern Ireland
Belfast, County Antrim
United Kingdom
emma.regan@belfasttrust.hscni.net

PS10.3 | 3/4/2017 | 9:30AM

Parents' Perspectives of Infants Using Modified Toy Cars

Samhita Rhodes, PhD

Grand Valley State University
Grand Rapids, Michigan
United States
rhodesam@gvsu.edu

PS10.1 | 3/4/2017 | 9:30AM

Changes in EEG Spectra in Response to Power Mobility Training

Laura Rice, PhD, MPT, ATP

University of Illinois
Champaign, Illinois
United States
ricela@illinois.edu

PS2.4 | 3/2/2017 | 2:30PM

Effectiveness of Transfer Training for Wheelchair Users with Multiple Sclerosis

Stephanie Rigot, SPT

Human Engineering Research Laboratories, University of Pittsburgh
Pittsburgh, Pennsylvania
United States
rigots@pitt.edu

PO1.18 | 3/2/2017 | 8:30AM

Biomechanical Effects of Training on Wheelchair-Commode Transfers

Karen Rispin

LeTourneau University
Longview, Texas
United States
karenrispin@letu.edu

PS7.1 | 3/3/2017 | 3:00PM

Interrater Reliability of the Wheelchair Components Questionnaire

PS7.4 | 3/3/2017 | 3:00PM

Reliability of the Aspects of Wheelchair Mobility Protocol

Tina Roesler, PT, MS, ABDA

Motion Composites
St Roch De l'Achigan, Quebec
Canada
tina@motioncomposites.com

PC03 | 2/28/2017 | 8:00AM

Set up for Success! Trials and Tribulations of Wheelchair Setup and Delivery

IC57 | 3/3/2017 | 4:30PM

The Seating Clinic: Business Realities for Success

IC75 | 3/4/2017 | 9:30AM

The Clinician Scientist: A Foundation for Leadership

Max Rogmans, MD

Vicair
Wormer, New Hampshire
Netherlands
c.kramer@vicair.com

IC33 | 3/3/2017 | 11:00AM

Introduction of the Total Shear Measurement Device, iShear

Russ Rolt

Active Controls
Sewell, New Jersey
United States
info@activecontrols.com

IC07 | 3/2/2017 | 1:00PM

The Wheelchair Drive Control as a Critical Positioning Device

Lauren Rosen, PT, MPT, MSMS, ATP/SMS

St. Joseph's Children's Hospital of Tampa
Tampa, Florida
United States
PTLauren@aol.com

IC22 | 3/2/2017 | 4:00PM

A Pommel Does What?

IC63 | 3/3/2017 | 4:30PM

Running a Seating Clinic 102: Going Beyond the Basics

Marc Rosen, ATP

Monroe Wheelchair
Latham, New York
United States
mrosen@monroewheelchair.com

IC73 | 3/4/2017 | 9:30AM

Custom Molding; Who, Why and How Tips
from the Collaborative Team

Lisa Rotelli, AS

Adaptive Switch Labs, Inc
Spicewood, New York
United States
lrotelli@asl-inc.com

PC14 | 3/1/2017 | 8:00AM

Powered Mobility Training for First Time Users

IC59 | 3/3/2017 | 4:30PM

Integration of Powered Mobility, AAC, & Computers

Paula Rushton, OT, PhD

Universite de Montreal
Montreal, Quebec
Canada
paula.rushton@umontreal.ca

PS5.2 | 3/3/2017 | 11:00AM

A Global Description of Wheelchair Service Education

PS7.3 | 3/3/2017 | 3:00PM

Wheelchair Skills Training: University Course vs. Boot Camp

IC28 | 3/3/2017 | 9:30AM

How Do We Learn the Skills to Become Seating Therapists?

Michael Ruyman, ATP

Handi Medical Supply
St. Paul, MN
United States
mruyman@handimedical.com

PC08 | 3/1/2017 | 1:00PM

The Wheelchair Clinic Experience: Effective, Efficient, Empowering

S

Andrina Sabet, PT, ATP

Cleveland Clinic Children's Hospital for Rehabilitation
Cleveland, Ohio
United States
andrinaset@gmail.com

IC38 | 3/3/2017 | 11:00AM

Driving for Change: Ending Barriers and Paving the Way for Play

Andrina Sabet, PT, ATP

Cleveland Clinic Children's Hospital for Rehabilitation
Cleveland, Ohio
United States
andrinaset@gmail.com

PC01 | 2/28/2017 | 8:00AM

Go Baby Go: An Innovative Method to Provide Mobility for Children

PC01 | 2/28/2017 | 8:00AM

Go Baby Go: An Innovative Method to Provide Mobility for Children

Ben Salatin, MS

US Department of Veterans Affairs
Albuquerque, New Mexico
United States
benjamin.salatin@va.gov

IC48 | 3/3/2017 | 1:30PM

Rehab Engineers + 3D Printing + Electronics = Personalized AT

Andi Saptono, PhD

University of Pittsburgh
Pittsburgh, Pennsylvania
United States
ans38@pitt.edu

PS9.4 | 3/4/2017 | 8:00AM

Self-care Mobile Health Platform for
Individuals with Spinal Cord Injury

Bonita Sawatzky

bonita.sawatzky@ubc.ca

IC75 | 3/4/2017 | 9:30AM

The Clinician Scientist: A Foundation for Leadership

Richard Schein, PhD, MPH

University of Pittsburgh
Pittsburgh, Pennsylvania
United States
rms35@pitt.edu

IC04 | 3/2/2017 | 1:00PM

Update on Functional Mobility Assessment and Uniform Data Set

PS2.2 | 3/2/2017 | 2:30PM

Assessment of Seat Elevator User Satisfaction

Vince Schiappa, MS

University of Pittsburgh
Pittsburgh, Pennsylvania
United States
vjs19@pitt.edu

IC04 | 3/2/2017 | 1:00PM

Update on Functional Mobility Assessment and Uniform Data Set

PS2.2 | 3/2/2017 | 2:30PM

Assessment of Seat Elevator User Satisfaction

Mark Schmeler, PhD, OTR/L, ATP

University of Pittsburgh
Pittsburgh, Pennsylvania
United States
schmeler@pitt.edu

IC04 | 3/2/2017 | 1:00PM

Update on Functional Mobility Assessment and Uniform Data Set

PS2.2 | 3/2/2017 | 2:30PM

Assessment of Seat Elevator User Satisfaction

PS8.2 | 3/3/2017 | 4:30PM

RCT on Wheeled Mobility for Pressure Injury Prevention

Britta Schwartzhoff, PT, DPT

Gillette Children's Specialty Healthcare
St. Paul, Minnesota
United States
brittaschwartzhoff@gillettechildrens.com

PC08 | 3/1/2017 | 1:00PM

The Wheelchair Clinic Experience: Effective, Efficient, Empowering

Nicky Seymour, OT

Motivation Charitable Trust
Cape Town, Western Cape
South Africa
seymour@motivationafrica.org.za

PS5.2 | 3/3/2017 | 11:00AM

A Global Description of Wheelchair Service Education

Mary Shea, MA, OTR, ATP

Kessler Foundation and Kessler Institute for Rehabilitation
West Orange, New Jersey
United States
MShea@kessler-rehab.com

IC36 | 3/3/2017 | 11:00AM

Group Wheelchair Skills Training- Setting and Achieving Goals

IC66 | 3/4/2017 | 8:00AM

Air Travel with a Wheelchair: What Seating Experts Should Know

I Made Agus Setiawan

University of Pittsburgh
Pittsburgh, Pennsylvania
United States
ims13@pitt.edu

PS9.4 | 3/4/2017 | 8:00AM

Self-care Mobile Health Platform for
Individuals with Spinal Cord Injury

Sheilagh Sherman, BA, BSc OT, MHM

Sunrise Medical
Concord, Ontario
Canada
sheilagh.sherman@sunmed.com

IC80 | 3/4/2017 | 9:30AM

Expanding Roles of Therapist Assistants and Wheelchair Provision

Satoshi Shirogane, PhD

Research Institute, National Rehabilitation
Center for Persons with Disabilities
Tokorozawa, Saitama
Japan
shirogane-satoshi@rehab.go.jp

PO1.4 | 3/2/2017 | 8:30AM

Sheet Type Sensor for Monitoring of Shear Force on Wheelchair

Nancy Shuster, EdS, MS, OTR, ATP

Community Health Network
Wallingford, Connecticut
United States
nshuster@chnct.org

IC19 | 3/2/2017 | 4:00PM

Environmental and Mobile Device Access for Power Wheelchair Users

Alexander Siefert, PhD

Wölfel Engineering GmbH + Co.KG
Bavaria
Germany
siefert@woelfel.de

IC13 | 3/2/2017 | 2:30PM

Posture, the Missing Link in Finite Modeling

Mary Simonson, OTL

Santa Clara Valley Medical Center
San Jose, California
United States
Mary.Simonson@hhs.sccgov.org

IC35 | 3/3/2017 | 11:00AM

Are Environmental Control Units (ECUs) a Thing of the Past?

Barbara Sipper, PTA

The Center for Discovery
Harris, New York
United States
bsipper@tcfcd.org

IC73 | 3/4/2017 | 9:30AM

Custom Molding; Who, Why and How Tips
from the Collaborative Team

Carina Siracusa, PT

OhioHealth
Columbus, Ohio
United States
carina.siracusa@OhioHealth.com

IC74 | 3/4/2017 | 9:30AM

Providing Assistive Technology for the MS Client

Robin Skolsky, MSPT, ATP

The Shepherd Center
Atlanta, Georgia
United States
Robin_Skolsky@shepherd.org

IC37 | 3/3/2017 | 11:00AM

School of Power Mobility: Tips for Teaching Power Mobility Skills

Colleen Smith, PT, DPT, ATP

Kennedy Krieger Institute
Baltimore, Maryland
United States
smithco@kennedykrieger.org

IC47 | 3/3/2017 | 1:30PM

Solving Complex Seating Clinic Challenges in an Intense Climate

Emma Smith, MScOT, ATP/SMS

University of British Columbia
Vancouver, British Columbia
Canada
smithem@alumni.ubc.ca

PC12 | 3/1/2017 | 8:00AM

Mobile Device Access and Integration for Wheelchair Users

IC12 | 3/2/2017 | 2:30PM

Powered Wheelchair Provision: Current Practices and Opportunities

Sharon Sonenblum, PhD

Georgia Institute of Technology
Atlanta, Georgia
United States
ss427@gatech.edu

IC29 | 3/3/2017 | 9:30AM

What Happens When You Sit? Explaining Seated Buttocks Deformation

Jill Sparacio, OTR/L, ATP/SMS, ABDA

Sparacio Consulting Services
Downers Grove, Illinois
United States
otspar@aol.com

PC07 | 3/1/2017 | 8:00AM

Dynamic Seating - Providing Movement and Why

IC49 | 3/3/2017 | 3:00PM

Custom Molded Seating: Back to the Basics

Stephen Sprigle, PhD, PT

Georgia Institute of Technology
Atlanta, Georgia
United States
stephen.sprigle@design.gatech.edu

IC29 | 3/3/2017 | 9:30AM

What Happens When You Sit? Explaining Seated Buttocks Deformation

Kevin Stahr, OTR/L, AT

The Ohio State University Medical Center
Columbus, Ohio
United States
kevin.stahr@osumc.edu

PS9.3 | 3/4/2017 | 8:00AM

Wheelchair Rugby Project: Academic and Clinical Collaboration

Melanie Stephens, MA, BSc, RN

University of Salford
Salford, Greater Manchester
United Kingdom
m.stephens@salford.ac.uk

PS6.4 | 3/3/2017 | 1:30PM

Factors Affecting Seating Prescription: An Evaluation of Watercell Technology in Complex Static Chairs

Maureen Story, BSR(PT/OT)

Sunny Hill Health Centre for Children
Vancouver, British Columbia
Canada
mstory@cw.bc.ca

IC20 | 3/2/2017 | 4:00PM

Developing Competencies for Seating & Mobility Specialists

Gina Strack, OTR, ATP

Townsend Rep Group
Houston, Texas
United States
gina@townsendrepgroup.com

IC67 | 3/4/2017 | 8:00AM

Solution to Complex Drive Systems with the ALS Population

Andrea Stump, PT, DPT, NCS

OhioHealth
Columbus, Ohio
United States
andrea.stump@ohiohealth.com

IC74 | 3/4/2017 | 9:30AM

Providing Assistive Technology for the MS Client

Sharon Sutherland (Pratt), PT

Seating Solutions, LLC
Longmont, Colorado
United States
sharonpra@msn.com

PC07 | 3/1/2017 | 8:01AM

Dynamic Seating - Providing Movement and Why

IC62 | 3/3/2017 | 4:30PM

Evaluation of Saddle Seating for Children with Special Needs

IC25 | 3/3/2017 | 9:30AM

The Other Seat! Critical Considerations for Bathroom Equipment

T

Melissa Tally, PT

Perlman Center Cincinnati Children's
Cincinnati, Ohio
United States
Melissa.Tally@cchmc.org

IC54 | 3/3/2017 | 3:00PM

To Abduct or Not Abduct: That is the Question

Stephanie Tanguay, OTR, ATP

Invacare- Motion Concepts- Educational Specialist
Royal Oak, Michigan
United States
stanguay@motionconcepts.com

IC21 | 3/2/2017 | 4:00PM

The Past, Present and Future of Tilt & Recline

IC28 | 3/3/2017 | 9:30AM

How Do We Learn the Skills to Become Seating Therapists?

Marshall Tempest

University of Pittsburgh Medical Center
Steubenville, Ohio
United States
tempestml@upmc.edu

IC72 | 3/4/2017 | 8:00AM

Back to the "Ideal" Ultralight Manual Wheelchair

Diane Thomson, MS, OTR/L, ATP

Rehab Institute Michigan (RIM)
Detroit, Michigan
United States
diane.b.thomson@gmail.com

PC02 | 2/28/2017 | 8:00AM

Foundations of Wheelchair Seating & Mobility Evaluations

Maria Toro Hernandez, PhD

Universidad Ces
Medellin, Antioquia
Colombia
mhtoro@ces.edu.co

PS5.2 | 3/3/2017 | 11:00AM

A Global Description of Wheelchair Service Education

IC56 | 3/3/2017 | 3:00PM

An Online Wheelchair Maintenance Training Program for Clinicians

Shigeru Toyama, PhD

National Rehabilitation Center for Persons with Disabilities
Tokorozawa, Saitama
Japan
toyama-shigeru@rehab.go.jp

PO1.4 | 3/2/2017 | 8:30AM

Sheet Type Sensor for Monitoring of Shear Force on Wheelchair

Elizabeth Trodler, MOTS

University of Texas Health Science Center San Antonio
San Antonio, Texas
United States
Trodler@livemail.uthscsa.edu

PO1.1 | 3/2/2017 | 8:30AM

Early Mobility Intervention: An Innate Right

Chung-Ying Tsai, PT

Human Engineering Research Laboratories, University of Pittsburgh
Pittsburgh, Pennsylvania
United States
cht60@pitt.edu

PO1.18 | 3/2/2017 | 8:30AM

Biomechanical Effects of Training on Wheelchair-Commode Transfers

Kalai Tsang, BS

Human Engineering Research Lab
Pittsburgh, Pennsylvania
United States
kat85@pitt.edu

PS2.1 | 3/2/2017 | 2:30PM

Adapting Commercial Wearable Fitness
Technology for Manual Wheelchair Users

Raheleh Tschoepe, MS, OT/L

University of North Carolina - Chapel Hill Division of
Occupational Science and Occupational Therapy
Chapel Hill, North Carolina
United States
tschoepe@med.unc.edu

PS3.2 | 3/2/2017 | 4:00PM

Advocating Necessity for Bluetooth Power Mobility Integration

Sue Tucker, OTD, OTR/L, ATP

Washington University
St. Louis, Missouri
United States
tuckers@wustl.edu

PS3.3 | 3/2/2017 | 4:00PM

Outcomes in a Community-Based Wheelchair Seating Clinic

PS3.4 | 3/2/2017 | 4:00PM

Motor Learning Approach for Training Manual Wheelchair Users

Patricia Tully, OTR

TIRR Memorial Hermann
Houston, Texas
United States
trishtullyot@gmail.com

PC02 | 2/28/2017 | 8:00AM

Foundations of Wheelchair Seating & Mobility Evaluations

U

Atsuki Ukita, OT

Social Medical Corporation Hokuto, Tokachi Rehabilitation Center
Obihiro, Hokkaido
Japan
a.ukita19@gmail.com

PO1.3 | 3/2/2017 | 8:30AM

The Effect of Wheelchair Back Support Shape on Reach Accuracy

V

Jaxon Vallely, BPhil

jyv27@pitt.edu

PS6.2 | 3/3/2017 | 1:30PM

An MRI Investigation Evaluating Tissue Response to Seat Cushions

Bart Van der Heyden, PT

Prive Pt Practice, De Kine - SuperSeating
Destelbergen,
Belgium
info@super-seating.com

IC13 | 3/2/2017 | 2:30PM

Posture, the Missing Link in Finite Modeling

Akhila Veerubhotla, MS

Human Engineering Research Laboratory (HERL)
Pittsburgh, Pennsylvania
United States
alv47@pitt.edu

PS9.1 | 3/4/2017 | 8:00AM

Using Wearable Sensors to Track Upper Extremity
Motion in Rehabilitation: A Literature Review

Lindsey Veety, PT, DPT, ATP

The Center for Discovery
Harris, New York
United States
lveety@tcfcd.org

IC73 | 3/4/2017 | 9:30AM

Custom Molding; Who, Why and How Tips
from the Collaborative Team

Tamara Vos-Draper, OT, ATP, SMS

Mayo Clinic
Rochester, Minnesota
United States
vosdraper.tamara@mayo.edu

PS8.1 | 3/3/2017 | 4:30PM

System Requirements for Continuous Seat Pressure Mapping

W

Thelma Wakefield, OTR

Eleanore's Project
Missoula, Montana
United States
sandwakefield@myfairpoint.net

PO1.15 | 3/2/2017 | 8:30AM

Eleanore's Project: Wheelchairs and 24-Hour Postural Care in Peru

Ann Weesie Walker, ATP/SMS

NRRTS
Lubbock, Texas
United States
wwalker@nrrts.org

IC42 | 3/3/2017 | 1:30PM

Documentation for Complex Rehab Technology: The Ethical Dilemma

Carla Walker, OTD, OTR/L, ATP

Washington University Program in Occupational Therapy
St. Louis, Missouri
United States
walkerc@wustl.edu

PS3.1 | 3/2/2017 | 4:00PM

Beyond Mobility: Above Knee Amputee Case Study

Ginger Walls, PT, MS, NCS, ATP/SMS

Permobil
Lebanon, Tennessee
United States
ginger.walls@permobil.com

IC43 | 3/3/2017 | 1:30PM

Overcoming Barriers to Best Practice: Keep the Client First!

Hongwu Wang, PhD

University of Pittsburgh
Pittsburgh, Pennsylvania
United States
how11@pitt.edu

IC16 | 3/2/2017 | 2:30PM

Assistive Robotics to Support Activities of Daily Living

Amber Ward, MS, OTR/L, BCPR, ATP/SMS

CHS- Neurosciences Institute Neurology
Charlotte, North Carolina
United States
amber.ward@carolinashealthcare.org

IC52 | 3/3/2017 | 3:00PM

Meeting the Unmet Need: Encouraging and Educating Therapists

Mark Warner, PT, ATP

VA Medical Center Dayton, Oh
Dayton, Ohio
United States
mark.warner4@va.gov

IC60 | 3/3/2017 | 4:30PM

Ideas to Innovation: Student Design Projects and Capstone Projects

Lin Wei, MS

Human Engineering Research Laboratories
Pittsburgh, Pennsylvania
United States
liw49@pitt.edu

PS2.3 | 3/2/2017 | 2:30PM

Evaluating Wheelchair Transfer Technique by Microsoft Kinect

Lotte Wemmenborn

Krabat
Lunde, Sweden
lotte@fysionord.se

IC62 | 3/3/2017 | 4:30PM

Evaluation of Saddle Seating for Children with Special Needs

Debora Wilkinson

University of Pittsburgh
Sun City Center, Florida
United States
WilkinsonD67@gmail.com

PS8.2 | 3/3/2017 | 4:30PM

RCT on Wheeled Mobility for Pressure Injury Prevention

Ashley Williams, PT, DPT

Comfort Company
Venice, Florida
United States
ashley.williams@comfortcompany.com

IC22 | 3/2/2017 | 4:00PM

A Pommel Does What?

Hyun Wook Ka, PhD

akoontz@pitt.edu
Pittsburgh, Pennsylvania
United States
hyk21@pitt.edu

PS2.3 | 3/2/2017 | 2:30PM

Evaluating Wheelchair Transfer Technique by Microsoft Kinect

Lynn Worobey, PhD, DPT, ATP

University of Pittsburgh
Pittsburgh, Pennsylvania
United States
lynn.worobey@pitt.edu

PO1.18 | 3/2/2017 | 8:30AM

Biomechanical Effects of Training on Wheelchair-Commode Transfers

IC36 | 3/3/2017 | 11:00AM

Group Wheelchair Skills Training- Setting and Achieving Goals

PS4.3 | 3/3/2017 | 9:30AM

Wheelchair Breakdowns and Hospitalizations
in People with Spinal Cord Injury

Y

Amber Yampolsky, PT, ATP, CPST

Nemours Children's Hospital
Orlando, Florida
United States
amber.yampolsky@nemours.org

IC78 | 3/4/2017 | 9:30AM

Car Seats and Vehicular Transport for Children with Special Needs

Z

Knut Magne Ziegler-Olsen, PT

Nav Center of Assistive Technology Oslo and Akershus
Oslo
Norway
km-ols@online.no

PO1.6 | 3/2/2017 | 8:30AM

We Give People Possibilities; Special Adaptations for Activity

Brian Zita, OTS

University of Texas Health Science Center San Antonio
San Antonio, Texas
United States
zitaB@livemail.uthscsa.edu

PS7.2 | 3/3/2017 | 3:00PM

Proper Wheelchair Measurement and Fit

Amanda Zito, OTR/L

Orlando Health
Orlando, Florida
United States
Amanda.zito@orlandohealth.com

IC05 | 3/2/2017 | 1:00PM

The Integration of Wheelchair Mobility and Home Accessibility

Session #	Title	Primary Presenter	Location
Thursday, March 2nd 7:30am-8:30am			
	Exhibit Hall Open - Breakfast Provided		
Thursday, March 2nd 8:30am-10:30am			
SS2	Opening Session	Mark R. Schmeler	Presidential Ballroom
SS1.1	Virtual Analysis of the Posture Effect on Skin Integrity	Alexander Siefert	Presidential Ballroom
SS1.2	Outcomes: Just Do It- Circa 1994	Jane Fontein	Presidential Ballroom
SS1.3	Large Data- Keynote Address	Kenneth J. Ottenbacher	Presidential Ballroom
Thursday, March 2nd 10:30am-1:00pm			
PO1	Poster Session for CEU Credit		Exhibit Hall
	Exhibit Hall Open - Lunch Provided		
Thursday, March 2nd 1:00pm-2:15pm			
IC01	Using The Science of Materials to Compare Wheelchair Cushions	Darren Hammond	Presidential Ballroom CE
IC02	Complex Rehab Technology Update	Donald E. Clayback	Presidential Ballroom AB
IC03	What's in a Back?	Jane E. Fontein	Ryman Ballroom EF
IC04	Update on Functional Mobility Assessment and Uniform Data Set	Mark R Schmeler	Presidential Ballroom D
IC05	The Integration of Wheelchair Mobility and Home Accessibility	Julie M. Gaby	Ryman Ballroom BC
IC06	Go Baby Go? Stakeholder Perceptions of Powered Mobility Provision	Heather A. Feldner	Ryman Studio MNO
IC07	The Wheelchair Drive Control as a Critical Positioning Device	Michael Flowers	Ryman Ballroom AD
IC08	Development of Wheelchair Standards for Less-Resourced Settings	Anand Mhatre	Ryman Studio PQR
PS1	Paper Session 1		Ryman Studio L
PS1.1	Health Outcomes of Wheelchair Seated Posture in Older Veterans	Lelia S. Barks	Ryman Studio L
PS1.2	Developing a Seating Intervention for Older Veterans	Lelia S. Barks	Ryman Studio L
PS1.3	The Experience of Spinal Cord Injury and Wheelchair Use	Jenny Lieberman	Ryman Studio L
PS1.4	Specialty Clinical Experience in Seating and Mobility	Penny J. Powers	Ryman Studio L
Thursday, March 2nd 2:15pm-2:30pm			
	Break		
Thursday, March 2nd 2:30pm-3:45pm			
IC09	Understanding Pressure Injuries for Effective Prevention	Amit Gefen	Presidential Ballroom AB
IC10	What's the Latest: Medicare Documentation & Coverage Requirements	Claudia Amortegui	Presidential Ballroom CE
IC11	Optimizing the Ride: How Manual Wheelchair Configuration Enhances Function	Jennith Bernstein	Presidential Ballroom D
IC12	Powered Wheelchair Provision: Current Practices and Opportunities	Emma M. Smith	Ryman Ballroom AD
IC13	Posture, the Missing Link in Finite Modeling	Alexander Siefert	Ryman Ballroom EF
IC14	Understanding Paediatric Mobility Needs from Parental Perspective	Sheila McNeill	Ryman Ballroom BC
IC16	Assistive Robotics to Support Activities of Daily Living	Dan Ding	Ryman Studio PQR
PS2	Paper Session 2		Ryman Studio L
PS2.1	Adapting Commercial Wearable Fitness Technology for Manual Wheelchair Users	Kalai Tsang	Ryman Studio L
PS2.2	Assessment of Seat Elevator User Satisfaction	Vince Schiappa	Ryman Studio L
PS2.3	Evaluating Wheelchair Transfer Technique by Microsoft Kinect	Lin Wei	Ryman Studio L
PS2.4	Effectiveness of Transfer Training for Wheelchair Users with Multiple Sclerosis	Laura A. Rice	Ryman Studio L
Thursday, March 2nd 3:45pm-4:00pm			
	Break		
Thursday, March 2nd 4:00pm-5:15pm			
IC17	Early Vs. Late Intervention with Custom Molded Seating	Thomas R. Hetzel	Presidential Ballroom AB
IC18	Updating Referral Sources on Medicare Wheelchair Requirements	Laura J. Cohen	Ryman Ballroom AD
IC19	Environmental and Mobile Device Access for Power Wheelchair Users	John J. Doherty	Presidential Ballroom D
IC20	Developing Competencies for Seating & Mobility Specialists	Maureen Story	Presidential Ballroom CE
IC21	The Past, Present and Future of Tilt & Recline	Karen Ball	Ryman Ballroom BC
IC22	A Pommel Does What?	Lauren Rosen	Ryman Ballroom EF
IC23	A Lifespan Blueprint for DME: Cerebral Palsy	Jonathan M. Greenwood	Ryman Studio MNO
IC24	Advances in Upper Body Function; Here Come the Robots!	Chantal Bérubé	Ryman Studio PQR
PS3	Paper Session 3		Ryman Studio L
PS3.1	Beyond Mobility: Above Knee Amputee Case Study	Michael Bender	Ryman Studio L
PS3.2	Advocating Necessity for Bluetooth Power Mobility Integration	Raheleh G. Tschoepe	Ryman Studio L
PS3.3	Outcomes in a Community-Based Wheelchair Seating Clinic	Sue Tucker	Ryman Studio L
PS3.4	Motor Learning Approach for Training Manual Wheelchair Users	Sue Tucker	Ryman Studio L
Thursday, March 2nd 5:30pm			
SS3	Exhibit Hall Welcome Reception		Exhibit Hall
Thursday, March 2nd 8:00pm-11:00pm			
SS1	ISS One Party - Social Event		Country Music Hall of Fame
Friday, March 3rd 7:00am-8:00am			
	Exhibit Hall Open - Breakfast Provided		
Friday, March 3rd 8:00am			
SS4	Morning Plenary - Do We Really Need Big Data?	Jean Minkel and Panel	Presidential Ballroom AB
Friday, March 3rd 9:15am-9:30am			
	Break - Exhibit Hall Open		
Friday, March 3rd 9:30am-10:45am			
IC25	The Other Seat! Critical Considerations for Bathroom Equipment	Sharon L. Sutherland	Presidential Ballroom AB
IC26	Rehab on the Ropes: Round 2 of the CMS Competitive Bid Program	Deborah L. Pucci	Ryman Studio PQR
IC27	Positioning the Head	Michelle L. Lange	Presidential Ballroom CE
IC28	How Do We Learn the Skills to Become Seating Therapists?	Rhona Moot	Ryman Studio MNO

IC29	What Happens When You Sit? Explaining Seated Buttocks Deformation	Sharon Sonenblum	Ryman Ballroom EF
IC30	Power Mobility for Children with Multiple Severe Disabilities	Lisa K. Kenyon	Ryman Ballroom AD
IC31	Meeting Lifetime Mobility Needs of Spinal Cord Injury and Disease	Kara L. Murphy	Ryman Ballroom BC
IC32	An Introduction to Hybrid Alternative Driving Systems	Steven J. Mitchell	Presidential Ballroom D
PS4	Paper Session 4		Ryman Studio L
PS4.1	Effects of Adjusting Wheelchair Configuration on Ramp Propulsion	Sarah Bass	Ryman Studio L
PS4.2	Montana Postural Care Project: A 24-Hour Postural Care Model	Tamara L. Kittelson-Aldred	Ryman Studio L
PS4.3	Wheelchair Breakdowns and Hospitalizations in People with Spinal Cord Injury	Nathan S. Hogaboom	Ryman Studio L
PS4.4	An Ergonomic Comparison of Three Different Seated Transport Devices	Jefferson S. Griscavage	Ryman Studio L
Friday, March 3rd 10:45am-11:00am			
	Break		
Friday, March 3rd 11:00am-12:15pm			
IC33	Introduction of the Total Shear Measurement Device, iShear	Max Rogmans	Ryman Ballroom EF
IC34	Mobility Addendums; Getting it Right the First Time	Dan Fedor	Ryman Ballroom AD
IC35	Are Environmental Control Units (ECUs) a Thing of the Past?	Tricia Garven	Presidential Ballroom D
IC36	Group Wheelchair Skills Training – Setting and Achieving Goals	Lynn Worobey	Ryman Studio MNO
IC37	School of Power Mobility: Tips for Teaching Power Mobility Skills	Angie Kiger	Presidential Ballroom AB
IC38	Driving for Change: Ending Barriers and Paving the Way for Play	Andrina J. Sabet	Ryman Studio PQR
IC39	Conquer the Complexity of Writing a Letter of Medical Necessity	Erin Baker	Ryman Ballroom BC
IC40	New & Emerging Technologies: How to Ask the Right Questions When Evaluating Mobility Devices	Kendra L. Betz	Presidential Ballroom CE
PS5	Paper Session 5		Ryman Studio L
PS5.1	Second Generation of a Low-Cost Smart Wheelchair	Carlos Gonçalves	Ryman Studio L
PS5.2	A Global Description of Wheelchair Service Education	Paula W. Rushton	Ryman Studio L
PS5.3	Development of an Online Wheelchair List for Wheelchair Users	Anand Mhatre	Ryman Studio L
PS5.4	Evaluating the Effectiveness of Hybrid Wheelchair Training	A. Yohali Burrola Méndez	Ryman Studio L
Friday, March 3rd 11:30am-2:00pm			
	Exhibit Hall Open - Lunch Provided		
Friday, March 3rd 1:30pm-2:45pm			
IC41	CARF Accreditation in Assistive Technology	Dawn Hameline	Ryman Studio PQR
IC42	Documentation for Complex Rehab Technology: The Ethical Dilemma	Ann L. Walker	Presidential Ballroom CE
IC43	Overcoming Barriers to Best Practice: Keep the Client First!	Virginia Walls	Ryman Studio MNO
IC44	Empowering Practice: Evaluating Seating and Mobility Outcomes	William C. Miller	Ryman Ballroom AD
IC45	Seeing Opportunities for Success: Visual Factors for Positioning	Katherine Clark	Ryman Ballroom BC
IC46	Assessing Mobility for Those with Cortical Visual Impairment	Cindi Petito	Ryman Ballroom EF
IC47	Solving Complex Seating Clinic Challenges in an Intense Climate	Meredith Budai	Presidential Ballroom D
IC48	Rehab Engineers + 3D Printing + Electronics = Personalized AT	Ben Salatin	Presidential Ballroom AB
PS6	Paper Session 6		Ryman Studio L
PS6.1	Modeling Pressure Injury Conditions Caused by Toilet Seats	Amit Gefen	Ryman Studio L
PS6.2	An MRI Investigation Evaluating Tissue Response to Seat Cushions	David M. Brienza	Ryman Studio L
PS6.3	How a Cushion Can Effectively Protect Against Pressure Injury	Amit Gefen	Ryman Studio L
PS6.4	Factors Affecting Seating Prescription: An Evaluation of Watercell® Technology in Complex Static Chairs	Carol Bartley	Ryman Studio L
Friday, March 3rd 2:45pm-3:00pm			
	Break		
Friday, March 3rd 3:00pm-4:15pm			
IC49	Custom Molded Seating: Back to the Basics	Jill M. Sparacio	Ryman Ballroom BC
IC50	Power Adjustable Seat Height is Both Reasonable and Necessary!	Julie A. Piriano	Presidential Ballroom AB
IC51	Advanced Mobility Skills Training for Manual Wheelchair Users	Kendra L. Betz	Presidential Ballroom D
IC52	Meeting the Unmet Need: Encouraging and Educating Therapists	Amber L. Ward	Ryman Ballroom EF
IC53	Seating the 'Unseatable'	Stefanie Laurence	Presidential Ballroom CE
IC54	To Abduct or Not Abduct: That is the Question	Ginny Paleg	Ryman Ballroom AD
IC55	Adaptive Bathroom Equipment for Adults	Elaina M. Halkiotis	Ryman Studio MNO
IC56	An Online Wheelchair Maintenance Training Program for Clinicians	Sara Múnera	Ryman Studio PQR
PS7	Paper Session 7		Ryman Studio L
PS7.1	Interrater Reliability of the Wheelchair Components Questionnaire	Karen Rispin	Ryman Studio L
PS7.2	Proper Wheelchair Measurement and Fit	Rachel Arata-Maiers	Ryman Studio L
PS7.3	Wheelchair Skills Training: University Course vs. Boot Camp	Paula W. Rushton	Ryman Studio L
PS7.4	Reliability of the Aspects of Wheelchair Mobility Protocol	Karen Rispin	Ryman Studio L
Friday, March 3rd 4:15pm-4:30pm			
	Break		
Friday, March 3rd 4:30pm-5:45pm			
IC57	The Seating Clinic: Business Realities for Success	Theresa F. Berner	Presidential Ballroom AB
IC58	A Memorial to our Colleagues Who Have Passed - No CEU's	Gerry Dickerson	Ryman Ballroom AD
IC59	Integration of Powered Mobility, AAC, & Computers	Karen M. Kangas	Presidential Ballroom D
IC60	Ideas to Innovation: Student Design Projects and Capstone Projects	Mark P. Warner	Ryman Studio MNO
IC61	Comparative Effectiveness Research: A Conceptual Model in Wheelchair Service Provision	Deepan Kamaraj	Ryman Ballroom BC
IC62	Evaluation of Saddle Seating for Children with Special Needs	Sharon Sutherland	Ryman Ballroom EF
IC63	Running a Seating Clinic 102: Going Beyond the Basics	Ashley Williams	Presidential Ballroom CE
IC64	Colombian Wheelchair Sector: People, Policy, Products, and Provision	Sara Múnera	Ryman Studio PQR
PS8	Paper Session 8		Ryman Studio L
PS8.1	System Requirements for Continuous Seat Pressure Mapping	Tamara Vos-Draper	Ryman Studio L
PS8.2	RCT on Wheeled Mobility for Pressure Injury Prevention	David M. Brienza	Ryman Studio L
PS8.3	Design and Verification of a Paediatric Wheelchair Cushion	Maighread M. Ireland	Ryman Studio L
PS8.4	Simulating Terrain for Measuring Wheelchair Rolling Resistance	Patrick J. Barba	Ryman Studio L

Saturday, March 4th 7:00am-8:00am			
	Breakfast Provided - Presidential Lobby		
Saturday, March 4th 8:00am-9:15am			
IC65	Maximizing Outcomes In Step with Advancing Technology	Amy M. Morgan	Ryman Ballroom BC
IC66	Air Travel with a Wheelchair: What Seating Experts Should Know	Jessica Pedersen	Ryman Ballroom EF
IC67	Solution to Complex Drive Systems with the ALS Population	Pam Glazener	Presidential Ballroom CE
IC68	Research & Evidence-Based Practice for Pressure Management and Tissue Integrity	Brenlee Mogul-Rotman	Presidential Ballroom D
IC69	Sip'n Puff: A Thing of the Past?	David J. Kreutz	Ryman Studio MNO
IC70	Challenges and Solutions in Seating for Infants and Toddlers	Janice Hunt Herman	Presidential Ballroom AB
IC71	Creating Partnerships Among Clinicians and Engineering Programs	Lisa K. Kenyon	Ryman Studio PQR
IC72	Back to the "Ideal" Ultralight Manual Wheelchair	Rosemarie Cooper	Ryman Ballroom AD
PS9	Paper Session 9		Ryman Studio L
PS9.1	Using Wearable Sensors to Track Upper Extremity Motion in Rehabilitation: A Literature Review	Akhila Veerubhotla	Ryman Studio L
PS9.2	Common Sense about Usable, Accessible, and Inclusive Seating	Naomi J. Petersen	Ryman Studio L
PS9.3	Wheelchair Rugby Project: Academic and Clinical Collaboration	Maria Eismann	Ryman Studio L
PS9.4	Self-care Health Platform for Individuals with Spinal Cord Injury	Andi Saptono	Ryman Studio L
Saturday, March 4th 9:15am-9:30am			
	Break		
Saturday, March 4th 9:30am-10:45am			
IC73	Custom Molding; Who, Why and How Tips from the Collaborative Team	Lindsey Veety	Presidential Ballroom AB
IC74	Providing Assistive Technology for the MS Client	Carina M. Siracusa	Presidential Ballroom D
IC75	The Clinician Scientist: A Foundation for Leadership	Carmen P. Digiovine	Ryman Ballroom AD
IC76	Training and Education for Novice Wheelchair Users	Hsin-Yi Liu	Ryman Ballroom BC
IC77	Keep Calm and Evac On!	Kathryn J. Fisher	Ryman Studio PQR
IC78	Car Seats and Vehicular Transport for Children with Special Needs	Amber Yampolsky	Presidential Ballroom CE
IC79	AT Collaboration Between Occupational Therapists and Speech Language Pathologists in Adult Rehab	Amy Grace	Ryman Ballroom EF
IC80	Expanding Roles of Therapist Assistants and Wheelchair Provision	Sheilagh Sherman	Ryman Studio MNO
PS10	Paper Session 10		Ryman Studio L
PS10.1	Changes in EEG Spectra in Response to Power Mobility Training	Lisa K. Kenyon	Ryman Studio L
PS10.2	Is Empowering Indoor/Outdoor Mobility Medically Necessary?	Jill Barnett	Ryman Studio L
PS10.3	Parents' Perspectives of Infants Using Modified Toy Cars	Emma Regan	Ryman Studio L
PS10.4	Preliminary Design of Assistive Robotic Arm for Kitchen Tasks	Molly Jeffers	Ryman Studio L
Saturday, March 4th 10:45am-11:00am			
	Break		
Saturday, March 4th 11:00am-12:30am			
SS5	Closing Session	Soren Kaplan, Keynote Speaker	Presidential Ballroom

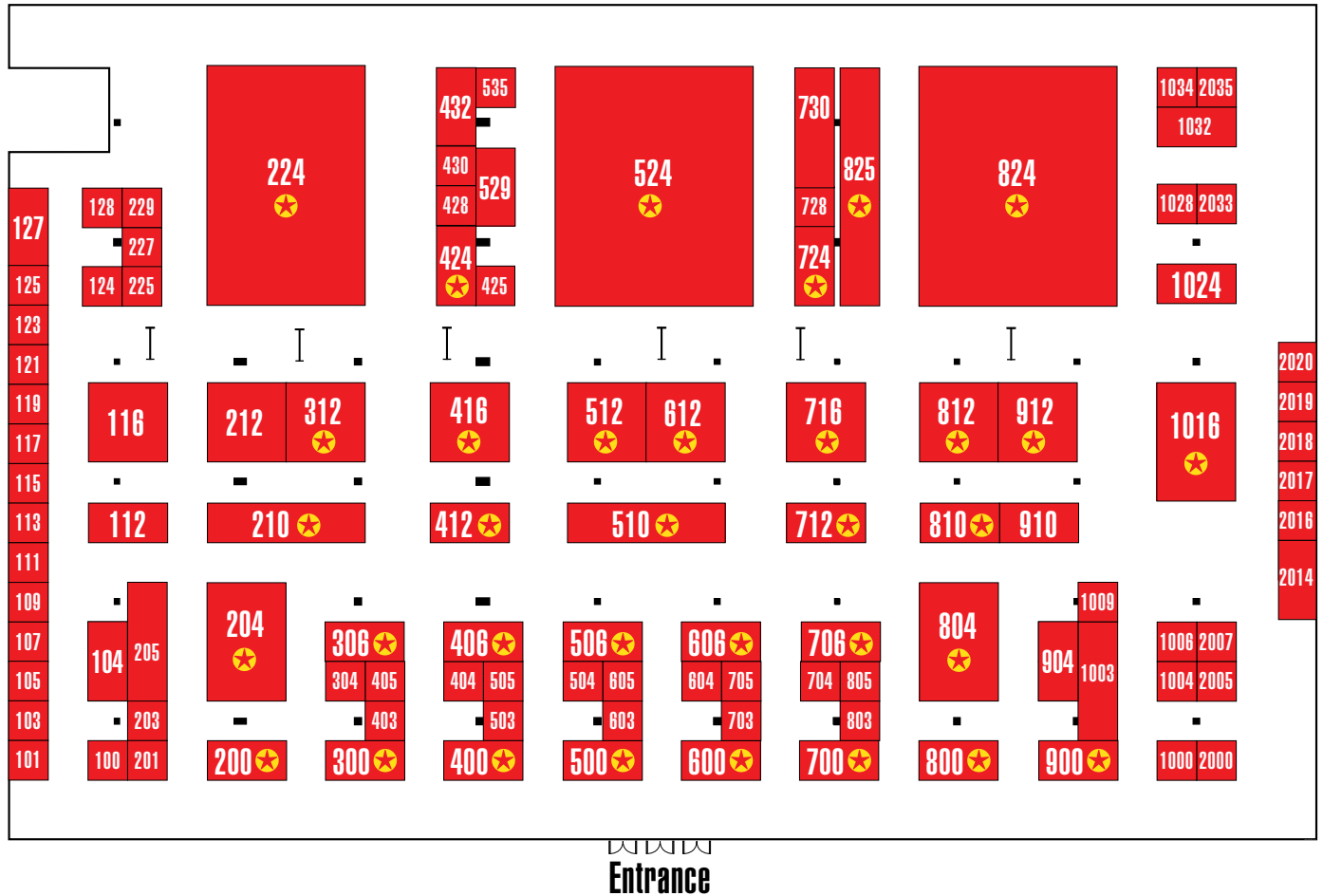

Exhibitors

A

Abram's Bed, LLC

129
Beth MacHine
300 Camp Horne Road
Pittsburgh, PA 15202
United States

beth@thesafetysleeper.com
412-766-3454

<http://www.thesafetysleeper.com>

Activeaid, Inc.

117
Charles Nearing
101 Activeaid Rd.
Redwood Falls, MN, 56283
United States

charles@activeaid.com
800-533-5330

<http://activeaid.com>

Adaptive Imports

104
Bob Brown
2744 Circleport Drive
Erlanger, KY, 41018
United States

bob@adaptiveimports.com
877-767-9462

<https://www.adaptiveimports.com>

Adaptive Switch Laboratories, Inc

535
Codie Ealey
Po Box 636 125 Spur 191 Suite C
Spicewood, TX, 78669
United States

cealey@asl-inc.com
830-798-0005

<http://asl-inc.com>

AEL

500
Jill Patty
102 E Keefe Ave
Milwaukee, WI, 53212
United States

jpatty@aelseating.com
866-656-1486

<http://www.aelseating.com>

AKW Industries USA, Inc.

805
Chiu-Ty Te
8260 Gardenia Vista Rd
Riverside, CA, 92508
United States

TY@AKWINDUSTRIES.COM
951-742-3466

<http://www.akwindustries.com>

Alber USA

425
William Russell
1005 International Dr
Oakdale, PA, 15071
United States

bill.russell@alber-usa.com
888-426-8581

<http://www.alber-usa.com>

Amysystems

212
Rob Travers
1650 Chicoine
Vaudreuil-Dorion, QC, J7V8P2
Canada

rtravers@amysystems.com
450-424-0288

<http://amysystems.com>

Aquila Corporation

203
Steve Kohlman
3827 Creekside Lane
Holmenww, WI, 54636
United States

skohlman@aquilacorp.com
608-782-0031

<http://www.aquilacorp.com>

Artsco, Inc.

403
Melissa Albright
501 Lloyd St.
Pittsburgh, PA, 15208
United States

melissa@artscoinc.com
412-204-8683

<http://www.artscoinc.com>

Atlas Enterprise Software

119
Scott Higley
9125 Canyon Magic ave
Las Vegas, NV, 89129
United States

shigley@atms-us.com
800-399-6012

ATR - American Track Roadsters

424
Greg Peek
1500 W. Hampden Ave. Unit 3-C
Englewood, CO, 80110
United States

greg@longbikes.com
303-986-9300

<http://www.seatingdynamics.com>

B

Beds by George

716
Aaron Clow
51690 Creekside Drive
Granger, IN, 46530
United States

Aaron@bedsbygeorge.com
574-298-0390

<http://www.bedsbygeorge.com>

BlueSky Designs

703
Mary Kay Walch
2637 27th Ave. S. Suite 209
Minneapolis, MN, 55406
United States

mkwalch@blueskydesigns.us
612-724-7002

www.mountnmover.com

Bodypoint, Inc.

600
Charlotte Moore
558 1st Avenue South
Seattle, WA, 98104
United States

Charlottemoore@bodypoint.com
206-405-4555

www.bodypoint.com

Broda Seating

400
Tricia Boudreau
560 Bingemans Centre Drive
Kitchener, ON, N2B 3X9
Canada

tricia.boudreau@brodaseating.com
800-668-0637

<https://www.brodaseating.com>

C

CarboLife Technologies GmbH & Co. Kg

603
Mirko Filler
Hermann-Mende-Str. 5-7
Dresden, SAS, 01099
Germany

mirko@carbolife.de
004935128790561

<http://carbolife.de>

Christopher and Dana Reeve Foundation

2016
Jennifer Hatfield
636 Morris Turnpike Suite 3A
Short Hills, NJ, 07078
United States

jhatfield@christopherreeve.org
908-868-7236

<https://www.christopherreeve.org>

Clarke Health Care Products

432
Jay Everett
7830 Steubenville Pike
Oakdale, PA, 15071
United States

jeverett@clarkehealthcare.com
713-854-1922

<http://www.clarkehealthcare.com>

Clinton River Medical

123
Dietrich Mackel
70 S. Squirrel Rd.
Auburn Hills, MI, 48326
United States

dietrich@clintonrivermedical.com
248-330-1317

www.clintonrivermedical.com

Comfort Company

825
Eric Murphy
509 S. 22nd Ave
Bozeman, MT, 59718
United States

eric@comfortcompany.com
800-564-9248

www.comfortcompany.com

Convoid/R82

116
Nicole Fiamengo
2830 California Street
Torrance, CA, 90503
United States

nicole@convoid.com
310-755-7826

<http://www.convoid.com>

Creating Ability

2014
Kevin Carr
225 Ne Winona St.
Chatfield, MN, 55923
United States

Kevin@creatingability.com
507-202-2174

<http://creatingability.com>

Crosley Medical Products, Inc.

1000
60 South Second Street, Suite E
Deer Park, NY 11729

crosleymedical@aol.com
631-595-2547

<http://crosleymedicalproducts.com>

D

Daedalus Technologies, Inc.

2001
Dawn Drewery
2511 Vauxhall Place
Richmond, BC, V6V 1Z5
Canada

ddrewery@daessy.com
604-270-4605

<http://www.daessy.com>

Daher Manufacturing, Inc.

404
Doug Daher
16 Mazonod Road Unit 5
Winnipeg, MB, R2J 4h2
Canada

daherd@gmail.com
204-663-3299

<http://www.daherproducts.com>

Dynamic Health Care Solutions

306
Tony Persaud
753011 Second Line
Mono, ON, L9W2Z2
Canada

tonypersaud@dynamichcs.com
519-942-8441

<http://www.dynamichcs.com>

Dynamic Systems, Inc.

111
Susan Yost
104 Morrow Branch Rd.
Leicester, NC, 28748
United States

marketing@sunmatecushions.com
980-239-2954

<https://www.sunmatecushions.com>

E

EasyStand

1024
Brittany Mathiowetz
262 W 1st St
Morton, MN, 56270
United States

brittany@easystand.com
800-342-8968

<https://easystand.com>

Evac+chair North America

2033
Jeff Wolvovsky
3000 Marcus Avenue Suite 3e6
Lake Success, NY, 11042
United States

jeff@evac-chair.com
516-502-4240

<http://www.evac-chair.com>

F

FEAL AB

1034
Mats Sundstedt
Södra Industriområdet 23
Horndal, Dalarna, 77468
Sweden

mats.sundstedt@feal.se
+46-226-464111

<http://www.feal.se>

Freedom Concepts, Inc.

800
Evan Paterson
2087 Plessis Road
Winnipeg, MB, R3W1S4
Canada

evan@freedomconcepts.com
204-654-1074 ext.205

<http://www.freedomconcepts.com>

G

Gel Ovations

201
Chris Barnum
1030 Gallery Rd
Wilmington, DE, 19805
United States

chris@gelovations.com
302-999-7792

<http://www.gelovations.net>

Go! Mobility Solutions

225
Rick Goldstein
2100 N. Wilmot Road Suite 319
Tucson, AZ, 85712
United States

rick@GoesAnywhere.com
520-582-0014

<https://www.goesanywhere.com>

H

Healthline

121
Travis Magnuson
1065 E Story Rd.
Winter Garden, FL, 34787
United States

pvcmeds1@aol.com
407-656-0704

<http://www.healthlinemedical.com>

Healthwares Manufactures

604
Patty Porter
8649 East Miami River Road
Cincinnati, OH, 45247
United States

pporter@healthwares.com
513-353-3691

<http://www.healthwares.com>

HERL/ISWP

1009
Michael Lain
6425 Penn Avenue, Suite 400
Pittsburgh, PA 15206
United States

mil72@pitt.edu
412-822-3663

<http://herl.pitt.edu/>
<http://wheelchairnet.org/>

I

Innovation In Motion

730
Whittney Ash
201 Growth Parkway
Angola, IN, 46703
United States

whittney@mobility-usa.com
800-327-0681

<http://www.mobility-usa.com>

Innovative Concepts

728
Michael Potts
300 North State Street
Girard, OH, 44420
United States

mpotts@icrehab.com
330-545-6390

<http://www.icrehab.com>

Inspired by Drive

312
Kimmie Sirimitr
11724 Willake Street
Santa Fe Springs, CA, 90670
United States

marketing@columbiamedical.com
562-282-0244

<http://www.columbiamedical.com>

Invacare

534
Jeff Steiss
1 Invacare Way
Elyria, OH, 44035
United States

jsteiss@invacare.com
440-329-6029

<http://www.invacare.com>
2035: iShear

iShear

2035
Damy Gertsen
Bruynvisweg 5
1531 AX Wormer
Netherlands

support@ishear.com
+3175 6429 999

www.ishear.com

K

Kaji Corporation

2000
Atsuko Kawanishi
3-2-7 Hikaridai, Seikacho, Sorakugun
Kyoto, 6190237
Japan

a_kawanishi@exgel.jp
8-177-498-2633

<http://www.exgel.jp/jpn/seating-lab/>

Kaye Products, Inc.

227
David Dillon
535 Dimmocks Mill Road
Hillsborough, NC, 27278
United States

kayeproducts@embarqmail.com
919-732-6444

<http://www.kayeproducts.com>

Ki Mobility

204, 205
Breianna Schneider
5201 Woodward Dr
Stevens Point, WI, 54481
United States

bschneider@kimobility.com
715-303-6155

<https://www.kimobility.com>

Kinova Robotics

606
Laurie Paquet
6110 Doris-Lussier
Boisbriand, QC, j7h0e8
Canada

lpaquet@kinovarobotics.com
514-771-7529

<http://www.kinovarobotics.com>

Kirton Healthcare

103
Beverly Lawrence
23 Rookwood Way
Haverhill, SFK, CB9 8PB
United Kingdom

beverlylawrence@kirtonhealthcare.co.uk
4401440705352

L

Leggero

412
Gabriela Romero
Po Box 485
Burnet, TX, 78611
United States

gabriela@leggero.us
830-613-6746

<http://www.leggero.us>

Leisure-Lift, Burke, Inc.

124
Duwayne Kramer Jr
1800 Merriam Lane
Kansas City, KS, 66106
United States

dekramer@burke-mobility.com
913-722-5658

Levo USA

910
James Papac
7105 Northland Terrace
Brooklyn Park, MN, 55428
United States

jimp@levousa.com
678-429-9459

<http://www.levousa.com>

LPA Medical, Inc.

706
Bryan Welch
2527 Ave Dalton
Quebec, QC, G0A1H0
Canada

bwelch@lpamedical.com
418-681-1313

<http://www.lpamedical.com>

M

Matrix Seating USA

430
Katherine Sims
10607 Sw 8th Ave.
Gainesville, FL, 32607
United States

Katherine@matrixseatingusa.com
Info@matrixseatingusa.com
800-986-9319

www.matrixseatingusa.com

Max Mobility

1016
Marc Richter
5425 Crossings Blvd
Antioch, TN, 37013
United States

mark@max-mobility.com
800-637-2980

www.max-mobility.com

Medifab Limited

900
Roger Mascull
Po Box 86027 Rolleston West
Rolleston, , 7658
New Zealand

roger@medifab.co.nz
643-307-9798

www.medifab.com

Metalcraft Industries, Inc.

100
Jim Swinehart
399 N Burr Oak Avenue
Oregon, WI, 53575
United States

Joan@Metalcraft-Industries.com
888-399-3232

<http://www.metalcraft-industries.com>

Merits/Avis Rehab

724
Todd Aiazzone
730 NE 19th Place
Cape Coral, FL 33909
United States

todd@meritsusa.com
800-963-7487

<http://www.meritsusa.com/page/avid.html>

Miller's Adaptive Technologies

105
Daniel Craig, Jr
2023 Romig Rd
Akron, OH, 44320
United States

dcr@millers.com
800-837-4544

<http://www.millersadaptive.com>

MK Battery

503
Destinie Jones
1631 S. Sinclair St.
Anaheim, CA, 92806
United States

djones@mkbattery.com
714-922-2021

www.mkbattery.com

Mobility Management

505
Susan May
14901 Quorum Drive Suite 425
Dallas, TX, 75254
United States

smay@1105media.com
972-687-6744

<https://mobilitymgmt.com>

Motion Composites

210
Eric Simoneau
519 J-Oswald Forest
Saint-Roch-De-L'achigan, QC, j0k3h0
Canada

eric@motioncomposites.com
450-588-6555

<http://www.motioncomposites.com>

Motion Concepts

529
Eric Simoneau
519 J-Oswald Forest
Saint-Roch-De-L'achigan, QC, j0k3h0
Canada

eric@motioncomposites.com
450-588-6555

<http://www.motioncomposites.com>

N

National Mobility Equipment Dealers Association (NMEDA)

712
Peter Lucas
3327 West Bearss Avenue
Tampa, FL, 33618
United States

plucas@nmeda.org
800-833-0427

<http://www.nmeda.com>

National Seating & Mobility

300
Bill Noelting
320 Premier Court Suite 220
Franklin, TN, 37067
United States

bnoelting@nsm-seating.com
615-595-1115

<http://www.nsm-seating.com>

NCART

2019
54 Towhee Court
East Amherst, NY 14051

716-839-9728

<http://www.ncart.us>

Noridian Healthcare Solutions and CGS Medicare

115
Lu Newell
900 42nd Street South
Fargo, ND 58103
United States

701-277-2489
lu.newell@noridian.com

www.noridianmedicare.com

NRRTS

2018
5815 82nd Street, Suite 145 #317
Lubbock, TX 79424

aodom@nrrts.org
800-976-7787

<http://www.nrrts.org>

Numotion

704
Mark Miller
155 Franklin Road Suite 100
Brentwood, TN, 37027
United States

mark.miller@numotion.com
423-505-5031

<http://www.numotion.com>

Nuprodx

605
Mark Homchick
889 Hayes St.
Sonoma™, CA, 95476
United States

mark@nuprodx.com
707-838-8578

<http://www.nuprodx.com>

O

Ottobock

912
Michal-Lynn Jakala
11501 Alterra Parkway Suite 600
Austin, TX, 78758
United States

ml.jakala@ottobock.com
512-806-2614

<http://www.ottobock.com/>

P

Panthera AB

510
Milja Winqvist
Gunnebogatan 26
Spanga, 16353
Sweden

milja@panthera.se
0046707614921

<http://www.panthera.se>

PDG Product Design Group

1032
Louise Tran
103 - 318 East Kent Avenue South
Vacouver, BC, V5X 4N6
Canada

ltran@pdgmobility.com
604-358-9106

<http://www.pdgmobility.com>

Penny and Giles Controls Ltd.

406
Mike Iles
10 Airspeed Road
Christchurch, DOR, BH23 4HD
United States

Jnash@curtisswright.com
509-306-9678

<http://www.curtisswright.com>

Permobil

824
Josh Anderson
2701 W Court St
Pasco, WA, 99301
United States

janderson@tilite.com
5095866117326

<http://www.permobil.com>

Precision Seating Solutions, LLC

803
Kirsten Davin
8755 Farmington Cemetery Road
Pleasant Plains, IL, 62677
United States

kirs10k@aol.com
217-414-2585

<http://www.pressuremapping256.com>

Prime Engineering

810
Dawn Cobb
4202 W Sierra Madre Ave
Fresno, CA, 93722
United States

dawn@primeengineering.com
559-276-0991

<http://www.primeengineering.com>

Prism Medical Ltd.

1003
Jeremy Bespalko
2201 Hangar Place, Ste. 200
Allentown, PA, 18109
United States

jbespalko@prismmedicaltd.com
314-346-7450

<http://www.prismmedicalinc.com>

PRM, Inc.

229
Todd Dinner
5325 Kuhl Road
Erie, PA, 16510
United States

tdinner@prmrehab.com
814-725-8731

<http://www.prmrehab.com>

PVA Publications/Paralyzed Veterans of America

109
Sherri Shea
2111 E. Highland Ave Suite 180
Phoenix AZ 85016
United States

sherri@pvamag.com
602-224-0500

<http://pvamag.com/pn/>

Q

Quantum Rehab

224
Debbie Gnall
182 Susquehanna Ave
Exeter, PA, 18643
United States

dgnall@pridemobility.com
570-655-5574

<http://www.quantumrehab.com>

R

Ram Mounts

428
Ashley Swearingen
8410 Dallas Ave. S.
Seattle, WA, 98108
United States

abs@rammount.com
206-763-8361

<http://www.rammount.com>

Raz Design, Inc.

512
Nelson Pang
19 Railside Road
Toronto, ON, M3A 1B2
Canada

npang@razdesigninc.com
416-751-5678

<http://razdesigninc.com>

REHAdapt North America

101
Robert McPherson
7619 A1a South
St, Augustine, FL, 32080
United States

rmp@rehadapt.com
904-687-0130

<http://rehadapt.com>

RESNA

2017
1700 North Moore Street
Suite 1540
Arlington, VA 22209

703-524-6686

<http://www.resna.org>

Ride Designs

812
Amanda Segebart
8100 Southpark Way, C400
Littleton, CO, 80120
United States

amandas@ridedesigns.com
866-781-1633

<http://www.ridedesigns.com>

Rifton

612
Deborah Keiderling
2032 Rt 213
Rifton, NY, 12471
United States

deborahkeiderling@ccimail.com
845-658-7700

<http://www.rifton.com>

Rowheels, Inc.

107
Rimas Buinevicius
3402 Viburnum Drive
Madison, WI, 53705
United States

rimas@rowheels.com
608-213-1207

<http://www.rowheels.com>

S

Shower Buddy, LLC

1006
Cheryl Oswill
12405 Montague Street
Pacoima, CA, 91331
United States

cheryl@myshowerbuddy.com
877-769-2833

<http://myshowerbuddy.com>

Simple Stuff Works Associates, Ltd

127
Anna Waugh
Units 4 and 5
Cavendish
Tamworth
United Kingdom

anna@simplestuffworks.co.uk

<http://www.simplestuffworks.co.uk>

SleepSafe Beds, LLC

506
Angie Daniel
3629 Reed Creek Drive
Bassett, VA, 24055
United States

adaniel@sleepsafebed.com
276-627-0088

<http://sleepsafebed.com>

Stars N Stripes Scooters

125
Mandy Chia
19140 Van Ness Ave
Torrance, CA, 90501
Canada

mandyc@snsscoters.com
626-213-4756

<http://www.snsscoters.com>

Stealth Products

416
Barry Steelman
104 John Kelly Drive
Burnet, TX, 78611
United States

barry@stealthproducts.com
800-965-9229

<https://www.stealthproducts.com>

Sunrise Medical

804
Laura Roese
6899 Winchester Cir #200
Boulder, CO, 80301
United States

laura.roese@sunmed.com
303-218-4463

<http://www.sunmed.com>

Supracor, Inc.

112
Brad Stern
2050 Corporate Ct
San Jose , CA, 95131
United States

bstern@supracor.com
408-432-1616

<http://www.supracor.com>

Symmetric Designs

128
Sam Hannah
125 Knott Place
Salt Spring Island, BC, V8K2M4
Canada

sam@symmetric-designs.com
250-537-2177

<http://www.symmetric-designs.com>

Synetik ErgoCare

2005
Lori-Pier Bacon
1242 De Lanaudiere
Joliette, QC, J6E3P1
Canada

lbacon@synetik-di.com
4507599449

Therafin Corporation

200
Marie Meents
9450 W Laraway Rd
Frankfort, IL, 60423
United States

marie@thera-fin.com
815-277-2813

<http://www.thera-fin.com>

TRG

504
Peggy Townsend
9330 Corporate Drive #605
Selma, TX, 78154
United States

ptownsend@townsendrepgroup.com
210-867-6562

<http://www.townsendrepgroup.com>

21st Century Scientific, Inc.

1028
RD Davidson
4931 N Manufacturing Way
Coeur D'alene, ID, 83815
United States

rdd@wheelchairs.com
208-667-8800

<http://www.wheelchairs.com>

T

Tamarack Habilitation Technologies

113
Jason Pawelsky
1670-94th Lane Ne
Minneapolis, MN, 55449
United States

jasonp@tamarackhti.com
763-795-0057

<http://www.tamarackhti.com>

Tekscan

1004
Lisa Bacon
307 West First St
South Boston, MA, 02127
United States

lbacon@tekscan.com
617-464-4500

<http://www.tekscan.com>

U

United Spinal Association

2020
United Spinal Association
120-34 Queens Blvd. #320
Kew Gardens, NY 11415
United States

718-803-3782
<https://www.unitedspinal.org>

U.S. Rehab

700
Sarah Eisenman
1111 W San Marnan Dr
Waterloo, IA, 50701
United States

sarah.eisenman@vgm.com
800-624-6065

<https://www.vgm.com>

V

Varilite

904
Karyn Abraham
4000 1st Ave S
Seattle, WA, 98134
United States

karyn.abraham@varilite.com
206-676-1451

<http://www.varilite.com>

Vista Medical Ltd.

705
Natalia Emelyanova
55 Henlow Bay Unit 3
Winnipeg, MB, R3Y1G4
Canada

salesadmin@vista-medical.com
204-949-7674

<http://www.pressuremapping.com>

W

WHILL

405
Chris Koyama
285 Old County Rd #6
San Carlos, CA, 94070
United States

chris@whill.us
415-638-3937

<http://whill.us>

X

Xsensor Technology

304
Ashley Wong
133 12 Ave Se
Calgary, AB, T2G 0Z9
Canada

ashley.wong@xsensor.com
403-266-6612

<http://www.xsensor.com>

Thursday

March 2, 2017

SS1.1: Virtual Analysis of the Posture Effect on Skin Integrity

Alexander Siefert, PhD

Bart Van der Heyden, PT

The Finite Element Method was initially developed in the 70's in the field of civil engineering to compute stresses and strains for the design of buildings. Within the last 40 years the capability and performance of this method are steadily improved due to hardware and software enhancements. A challenge for the FEM is the modelling of the human body. But within the last years great advancements are made in the field of biomechanics. A known example is the 3D heart project, where companies and clinical partners developed an active model of the human heart. Beside these scientific developments the FEM is more and more used in the development, where products are interacting with the human body. An example is the tool CASIMIR/Automotive used in the automotive industry to evaluate seating comfort. Here a seat design can be combined with different types of manikins in different postures.

Learning Objectives:

- List at least two applications of how findings from 3D FEM can be applied for wheelchair adjustments.
- Describe at least three influences of seat adjustments on tissue loads.
- List at least three effects of common postural adjustments on tissue loads.

References:

1. Oomens, C. W., Maenhout, M., Oijen, C. H., Drost, M. R., & Baaijens, F. P. (2003). Finite element modelling of contracting skeletal muscle. *Philosophical Transactions of the Royal Society B: Biological Sciences*, 358(1437), 1453-1460. doi:10.1098/rstb.2003.1345.
2. Siefert, A., Pankoke, S., & Wölfel, H. (2008). Virtual optimisation of car passenger seats: Simulation of static and dynamic effects on drivers' seating comfort. *International Journal of Industrial Ergonomics*, 38(5-6), 410-424. doi:10.1016/j.ergon.2007.08.016.
3. Loerakker, S. (2011). The relative contributions of muscle deformation and ischaemia to pressure ulcer development. PHD thesis, TU Eindhoven. ISBN 978-90-386-2550-8.

SS1.2: Outcomes: Just Do It – Circa 1994

Jane Fontein, OT

Outcomes has become a popular topic of conversation lately, however, despite all the talk it appears that only a few people are actually performing outcome measures. With funding becoming tighter it has become even more important that outcomes be performed. This is not just for the service providers but for all members of the seating team, including the suppliers and the manufacturers. Each team member will benefit from the information gathered. A commitment to performing outcomes by the audience will be made and a network for exchanging information will be set up.

Objectives

- Discuss the critical need to perform outcome measures as it relates to seating and mobility.
- Demonstrate what areas to cover in the evaluation process to enable outcomes to be measured.
- Demonstrate through an example that the process is not difficult or threatening.
- To leave with a concrete plan for each participants' setting.

References:

1. Bergen, Adrienne, F., P.T., Provision of Seating and Wheeled Mobility Issues in Continuing Quality Assurance, and Overview, Ninth International Seating Symposium "Seating the Disabled" Proceedings. pp. 163-167
2. England, B., M.A.; Glass, R.M.; Ed.D.; Pattersen, C.H., M.M., Quality Rehabilitation Results – Oriented Patient Care, A.H.A. American Hospital Publishing Inc., 1989
3. Fuhrer, Marcus J., PhD., Editor, Rehabilitation Outcomes Analysis and Management, Paul H. Brooks Publishing Company, 1987
4. Gill, Thelma, Med., BScOT, OT(C), Chairperson of Task Force, Toward Outcome Measures in Occupational Therapy, Minister of National Health and Welfare Publishing Authority, Ottawa, Ontario, June 1987
5. Luebben, Aimee J., Outcomes Management, Ninth International Seating Symposium "Seating the Disabled" Proceedings. pp. 163-167
6. Mortola, Paul J., O.T.R.; Kohn, Jean, M.D., M.P.H.; LeBlanc, Marice, M.S.M.E., C.P. Success through client follow-up. Team Rehab, Nov. 1992, pp. 49-51
7. Warren, C.G., MPA, Improving Intervention Through Quality Assurance, Ninth International Seating Symposium "Seating the Disabled" Proceedings. pp. 163-167

SS1.3: What is Data Science and How Will it Impact Rehabilitation Science?

Kenneth J. Ottenbacher, PhD, OTR

Data Science is operationally defined as using computer-based systems and processes to analyze large amounts of data and extract knowledge from them. At its core Data Science is the study of: 1) where information comes from, 2) what it represents, and 3) how it can be turned into knowledge that benefits human well-being. Data Science is an interdisciplinary field in which structured or unstructured information is examined using methods associated with statistics, data mining, predictive analytics, bioinformatics and model simulation. There are similarities between Data Science and Rehabilitation Science. Both are interdisciplinary, both involve the analyses and application of different forms of data, and both use a constantly changing combination of analytical and investigative approaches. To become partners in the emerging field of Data Science, rehabilitation scientists and practitioners must expand their research portfolio. The presentation will describe potential steps in building research capacity to use “Big Data” in addressing questions relevant to seating and mobility. The distinction between Large Data and Big Data will be discussed and opportunities involving the secondary analyses of data repositories and data sharing will be examined.

Learning Objectives

- Identify at least 3 methods which can be used to examine data.
- Identify 3 similarities between Data Science and Rehabilitation Science
- Describe 3 steps that can build research capacity to use Data Science to address issues in seating and mobility.

References

1. Roebuck K. Big Data. New York: McGraw Hill; 2011.
2. Roski J, Bo-Linn GW, and Andrews TA. Creating value in health care through Big Data: Opportunities and policy implications. *Health Aff* 2014;33:1115-1122.
3. Boslaugh S. Secondary Data Sources for Public Health: A Practical Guide. Cambridge University Press: Cambridge, UK; 2007.
4. Pietrobon R, Guller U, Martins H, Menezes AP, Higgins LD, Jacobs DO. A suite of web applications to streamline the interdisciplinary collaboration in secondary data analyses. *BMC Med Res Method*. 2004;4(1):29.

IC01: Using The Science of Materials to Compare Wheelchair Cushions

W. Darren Hammond, MPT, CWS

General Session Overview:

Too often therapists and providers who recommend seating and positioning products do not fully understand the reason(s) behind the design and the specific characteristics of product options. Prescribers sometimes rely on generalized assumptions, sales and marketing spin, and historical effectiveness for their justification regarding choosing one seating product over another.

It seems that the process involved in selecting clinically appropriate seat cushions for our wheelchair seated clients has switched gears somewhat from a purely artistic approach to perhaps a more evidence based or science based thought process. This is a welcome change in our industry and one we can all embrace.

This program will provide foundational knowledge of an alternative approach to the way the health care community chooses various seating support surfaces when discussing skin integrity, positioning and stability. A basic overview of scientific mechanisms by which load is applied and the resultant forces, which occur, will be discussed. Using scientific principles, the majority of the discussion will review the materials and the various design methods used to construct cushions in order to provide specific therapeutic benefits. In addition, participants will gain a greater understanding of varying load redistribution properties used to achieve specific clinical outcomes. Finally, quantifying methods used to compare and contrast wheelchair cushions will be discussed.

Objectives:

By the end of the presentation, participants will be able to:

- Explain two mechanisms and resulting forces that occur while load is applied to three different cushion materials
- List three different load redistribution methods used in cushion design and construction
- Explain the three quantifying methods used to compare and contrast cushion materials surfaces

Abbreviated Bibliography:

1. Brienza DM, Geyer MJ. (2005) Using Support Surfaces to Manage Tissue Integrity. *Adv Skin Wound Care*,18,151-7.
2. Brienza D, Kelsey S, Karg P, et al. (2010) A Randomized Clinical Trial on Preventing Pressure Ulcers with Wheelchair Seat Cushions. *Journal of The American Geriatrics Society*. 58(12), 2308-2314.
3. Ferguson-Pell M. (2005) Nicholson G. Bain D. Call E. Grady J. deVries J. The role of wheelchair seating standards in determining clinical practices and funding policy. *Assistive Technology*. 17(1),1-6.
4. Garber, S.L., and T. Krouskop. (1997) Technical advances in wheelchairs and seating systems. *Arch Phys Med Rehabil: State of the Art Reviews* 11, 93-106.
5. Gefen, A. (2014) Tissue Changes in Patients Following Spinal Cord Injury and Implications for Wheelchair Cushions and Tissue Loading: A Literature Review. *Ostomy Wound Management*. 60(2), 34-45.
6. Lizaka S, Nakagami G, Urasaki M, Sanada H. (2008) Influence of the "hammock effect" in wheelchair cushion cover on mechanical loading over the ischial tuberosity in an artificial buttocks model. *J Tissue Viability*. 18(2), 47-54.
7. Levy, A., Kopplin, K., & Gefen, A. (2014). An air-cell-based cushion for pressure ulcer protection remarkably reduces tissue stresses in the seated buttocks with respect to foams: Finite element studies. *Journal of Tissue Viability*, 23(1), 13-23.
8. Maklebust J. (2005) Choosing the right support surface. *Advances in Skin and Wound Care*. 18(3), 158-61.
9. Pipkin L and Sprigle S. (2008) Effect of model design, cushion construction, and interface pressure mats on interface pressure and immersion. *Journal of Rehabilitation Research and Development*. 45(5), 875-882.
10. Serway RA and Jewett JW. (2007) *Physics for Scientists and Engineers, Volume 1, Chapters 1-22, 7th edition.* Brooks Cole.
11. Serway RA and Jewett JW. *Physics for Scientists and Engineers, Volume 2, Chapters 23-46, 7th edition, Brooks Cole, Feb 2007.*
12. Shechtman, Orit, et al. (2001) Comparing Wheelchair Cushions for Effectiveness of Pressure Relief: A Pilot Study. *The Occupational Therapy Journal of Research*. 21(1).
13. Sprigle S, Call E, Pratt S. (2006) The Science of Seating Materials- Why Do We Care From a Clinical Perspective? Paper presentation: Authors: Proceedings of the 22nd International Seating Symposium.
14. Sprigle S, Chung KC, Brubaker CE. (1990) Reduction of sitting pressures with custom contoured cushions. *J Rehabil Res Dev*. 27,135-40.
15. Sprigle S, Linden M, McKenna D, et al. (2001) Clinical skin temperature measurement to predict incipient pressure ulcers. *Advances in Skin and Wound Care*. 14(3), 133-137.
16. Sprigle S. Press L. (2003) Reliability of the ISO wheelchair cushion test for loaded contour depth. *Assistive Technology*. 15(2), 145-50.

-
17. Stockton L, Rithalia S. (2008) Pressure-reducing cushions: perceptions of comfort from the wheelchair users' perspective using interface pressure, temperature and humidity measurements. temperature and humidity measurements. J Tissue Viability. 18(2), 28-35.

Contact Information:

W. Darren Hammond, MPT, CWS

Senior Director
The ROHO Institute of Education
ROHO / Permobil, Inc.

Darren.hammond@permobil.com

IC02: Complex Rehab Technology Update

Donald E Clayback

The world of Complex Rehab Technology (CRT) is undergoing significant changes. This session will review the legislative and regulatory issues in play that have a direct impact on access at the federal and state levels. Topics will include the Medicare Separate Benefit Category, the impact of Competitive Bidding, state Medicaid matters, and other important initiatives and trends. We'll also review the tools available to promote access to CRT with policy makers and payers and how to use them effectively.

Learning Objectives:

Upon completion of this session, attendees will be able to;

- Describe at least two of the latest issues regarding Medicare CRT legislation and other federal issues.
- Describe at least two of the latest topics regarding state Medicaid issues and activities.
- Describe at least two ways to protect CRT access on federal and state levels and the resources available to help.

References:

1. Congressional Legislation (2015). H.R. 1516 and S. 1013 Ensuring Access To Quality Complex Rehabilitation Technology Act of 2015.
2. Congressional Legislation (n.d.). H.R. 3229 and S. 2196 To provide for the non-application of Medicare competitive acquisition rates to complex rehabilitative wheelchairs and accessories.
3. Kaiser Family Foundation Studies (2016). Retrieved from www.kff.org/medicaid/index.cfm.

IC03: What's in a Back

Jane Fontein, OT

This hands on workshop will explore the properties of back supports and their impact on seating and positioning. Through demonstration and trial, the attendees will assess the differences from sling upholstery, tension adjustable, and rigid backs. . A review of back properties and their clinical implications will be discussed

Often referrals sent to a therapist will request that one aspect of the seating system, often the cushion, be assessed. When this occurs the therapist should request referral for a full seating assessment to adequately determine the cause of the issues presented. . When it comes to posture and skin health the cushion is only one aspect of seating and needs to be looked at in combination with the back support, the size of the equipment, and the overall wheelchair set up and configuration. The back support and the seat to back interface should be considered as an equal partner to the cushion when completing a seating assessment. Once a seating assessment has been performed, it is important to list the properties of the seating system that are required, in conjunction with the goals of the client.

The purpose of back supports are to support the pelvis and trunk but allow movement of thoracic area. Back supports can provide lateral stability and if a head support is needed allows for the attachment of the head support. How the pelvis and trunk are supported will depend on the structure of the back and cushion combined however it has been supported in a study by Kersti Samuelsson et al. "that a lumbar support and a shaped seat cushion are the most effective way to support the pelvic towards a neutral position. Most effective was a lumbar support" ¹.

When looking at a back system there are pros and cons (as generalizations) for having sling seat vs adjustable tension vs rigid and it will depend on the client. As in a cushion there is no one back for everyone as there is no one cushion. Generally, a sling back that comes with a chair does not allow for pelvic support and allows the pelvis to move into posterior pelvic tilt, which often leads to a kyphosis. Sling back supports will stretch over time as well, depending on the fabric. The advantage of a sling back is that if the chair is folded frequently it eliminates the step to remove a rigid back. A tension adjustable back, allows tightening and loosening of straps to accommodate for the posture of the user. It can give more support at the pelvis but may not prevent posterior pelvic tilt. Like the sling seat it allows for easy folding of the chair, but does add a little weight and also has to be maintained if the straps loosen. " The Velcro™-adjusted back support in our study formed a better support for pelvic position than the traditional sling back ." ¹.

There are many different types of rigid backs that come in many different shapes and sizes so it is difficult to make a statement about all rigid backs. However due to being rigid there is more ability to support the pelvis to help maintain a neutral position. But depending on the design the removability for folding varies from very simple to more

difficult. In a study by Yu-Sheng Yang et al. " Wheelchairs in this study were equipped with sling backrests. Studies have shown that the use of a sling backrest in a wheelchair can have a negative impact on posture and can be less supportive than a rigid back.^{3,6,28} In a recent study we investigated differences between a rigid backrest and the standard sling backrest on wheelchair propulsion variables in 26 MWUs with paraplegia. Under similar propulsion conditions as this study, the rigid backrest kept the trunk more up right, reduced non tangential propulsion forces, and increased MEF.²⁹ Consequently, there may be added benefits of pushing a wheelchair with a low rigid backrest instead of one with a low sling backrest."²

Once you have determined that a back support is required, there are several dimensions to be determined including the height (or length), width and lateral support required. Studies have shown that a back to high can limit shoulder movement and thus limit propulsion, it can also force a client into forward flexion. Too low, may limit the support provided and can lead to skeletal deformities. Determining the height will be part of the seating assessment however for independent propulsion it is better to have the height of the support below the lowest part of the scapula. Yu-Sheng Yang et al concluded that "Using a backrest height lower than 40.6cm (16in) afforded MWUs more freedom of arm movement, increased stroke angles, and decreased cadence. As a result, this simple modification in wheelchair setup could help decrease the risk of developing upper-limb overuse related injuries. The improvements found when using the low backrest were regardless of slope type. Consistent with findings in prior studies, pushing uphill demanded significantly higher resultant and tangential force, torque, MEF, and cadence. Ideally the backrest height should provide adequate postural support while affording as much freedom of arm movement as possible. Future studies should be directed on rigid backrests, as they come in various sizes and shapes and provide added benefits related to propulsion effectiveness and posture."²

The following is a list of potential properties to consider when looking at rigid back supports, depending on the needs of the client the priorities of which property is more important can change. These properties will be reviewed in the workshop as well as discussing their clinical implications.

- Pelvic support – how is it achieved
- Seat to back angles available
- Lateral support – positions, depth, adjustability, fixed contours or removable, swing away.
- Back height (length)- sizes
- Removability - ease
- Weight – including hardware
- Width sizes – some rigid backs fit different sizes of wheelchairs
- Angle adjustability within the back support
- Comfort (individual)
- Maintenance required
- Aesthetics
- Colour options
- Head support mounting options
- Shoulder strap mounting options

-
- Insert options for rigid backs, ie Foam or other materials... gel, air
 - Hardware – ease of mounting, adjustability, weight, reliability
 - Crash tested

References:

1. The effect of shaped wheelchair cushion and lumbar supports on under-seat pressure, comfort, and pelvic rotation. Kerstu /samyeksiibm, Marrut Bjork, Ann-Marie Erdugan, Anna-Karin Hansson & Birgitta Rustner; Faculty of Health Sciences, Department of Clinical and Experimental Medicine, Rehabilitation Medicine, Linkoping, Sweden, and Clinical Department of Rehabilitation Medicine, University Hospital, Linkoping, Sweden Disability and Rehabilitation: Assistive Technology, September 2009; 4(5): 329–336
2. Effect of Backrest Height on Wheelchair Propulsion Biomechanics for Level and Uphill Conditions Yu-Sheng Yang, PhD, Alicia M. Koontz, PhD, Shan-Ju Yeh, BS, Jyh-Jong Chang, PhD. Physical Medicine and Rehabilitation, April 2012 Volume 93, Issue 4, Pages 654–659

Contact:

Jane Fontein, OT

Janefontein – Independent Manufacturer Educator
(Dynamic Health Care Solutions and Motion Composites)
janefontein@gmail.com

IC04: Update on Functional Mobility Assessment and Uniform Data Set

Mark Schmeler, PhD, OTR/L, ATP

Richard Schein, PhD, MPH

Vince Schiappa, MS

Carmen P Digiovine, PhD, ATP/SMS,
RET

Standardized outcome measures and associated datasets are necessary to improve evidence and accountability in the field of mobility assistive equipment. This session will present updated developments in the Functional Mobility Assessment (FMA) registry along with the development of accompanied Uniform Data Set (UDS). Challenges and strategies associated with the implementation of standardized measures in clinical routine and associated data collection, aggregation, and analyses will be discussed from previous work and current collaborations with VGM/U.S. Rehab, The Ohio State University Medical Center, and Veteran's Administration.

Learning Objectives:

Upon completion of this session, attendees will be able to;

- Identify two reasons why the field needs a mobility registry
- Discuss the 10 items and scoring of the Functional Mobility Assessment (FMA) and elements of the associated database
- List 3 elements of the associated FMA Database/UDS

References:

1. Kumar, A., Schmeler, M.R., Karmarkar, A.M., Collins, D.A., Cooper, R., Cooper, R.A., Shin, H., & Holm, M.B. (2012). Test-retest reliability of the functional mobility assessment (FMA): a pilot study. *Disabil Rehabil Assist Technol*.
2. Gliklich, R.E., Dreyer, N.A., eds. (2010). *Registries for Evaluating Patient Outcomes: A User's Guide*. 2nd ed. AHRQ.
3. Mortenson, W.B., Miller, W.C., & Auger, C. (2008). Issues for the selection of wheelchair-specific activity and participation outcome measures: a review. *Arch Phys Med Rehabil*. 89: 1177-86.

IC05: The Integration of Wheelchair Mobility and Home Accessibility

Julie Gaby, MPA, OTR/L, ATP, CAPS

Home accessibility is often defined as the ability to approach, enter and navigate through the environment safely. With the advancements in both wheelchair and assistive technology the potential for the client to not only navigate, but control the environment allows the client greater comfort, safety and independence with their home. Advances wheelchair technology allow for greater access for transfers, activities of daily living and mobility, while the advancement of android and Apple products along with I Home and Alexa allow the client greater control of their environment . Knowledge of both areas is imperative for the mobility professional to be able to successfully provide the client with their accessibility needs. This power point presentation will give specific examples of product and services that integrate together and best serve the client in their home and accessibility needs.

In addition to recent advances in technology, we will also be reviewing some basic concepts in accessibility and universal design. We will discuss pros and cons of home designs and the impact of those designs on wheeled mobility. We will be discussing simple and cost efficient adaptations as well as more complex systems that are more costly. We will be providing information on possible funding sources.

Resources:

American Occupational Therapy Association (AOTA)

Link:

1. www.aota.org
2. Americans with Disability Act Link: ADA.gov
3. National Home Builders Association (NHBA) Link: nahb.org
4. American Association of Retired Persons (AARP) Link: www.aarp.org
5. Rebuilding Together Link: www.rebuildingtogether.org

Contact:

Julie Gaby

Arnold Palmer Hospital for Children,
Orlando, Florida 32803
juliegaby@orlandohealth.com

IC06: Go Baby Go? Stakeholder Perspectives of Powered Mobility Provision

Heather A. Feldner, PT, PhD, PCS

James C. Galloway, PT, PhD, FAPTA

Background

Mobility, regardless of form, is increasingly being acknowledged as a human right. Some scholars researching mobility technology have argued, from a rights-based perspective, that participation and access for disabled adults and children who use such technologies remain significantly compromised, but little is known about factors specific to the user or the provision process, especially in the case of young children and their families (Borg et al., 2011; Mortenson & Miller, 2008; Nicholson & Bonsall, 2005; Ripat & Woodgate, 2011).

Further, the field of rehabilitation, which has been a classic setting for intervention for disabled children with mobility impairments, has been historically underpinned by the medical model perspective, whereby disability is defined as an undesirable deficit residing in an individual, which results in the need for intervention to remediate, or normalize, such deficit as best as possible (Kielhofner, 2005). Although there have been recent challenges to this view of disability from within the field, resulting in a slow philosophical shift within more progressive professional circles, evidence of the medical model perspective remains pervasive (Gibson et al., 2011; Gibson & Teachman, 2012; Kielhofner, 2005; Wiart et al., 2004). Alternatively, the social model of disability, for example, claims that while bodily impairment exists, it is a value-neutral way of being in the world, and that disability is solely a constructed phenomenon- a combination of social, political, and environmental barriers- resulting in the persistent oppression of people with impairments (Charlton, 1998; Kielhofner, 2005). Some scholars in disability studies note that technology provision sits at the crossroads of the medical and social models of disability, where bodily experiences of impairment, as well as the social and physical barriers and discriminations faced by disabled people, both matter (Ripat & Woodgate, 2011; Siebers, 2008).

Ripat and Woodgate (2011) have asserted that Assistive Technology (AT) like a mobility device, as a prescriptive item historically provided within the rehabilitation framework as a reparation or compensation for the deficit of not walking, can be reimagined within a disability studies framework as a key means of access which prevents marginalization, addresses external participation limitations, and promotes empowerment (p. 89). Further, as Gudgeon and Kirk (2015) have pointed out, for children who use mobility technology, achieving 'fit' between self, device, and environment helps determine whether mobility experiences are considered positive or negative. Thus, examining this 'fit' from multiple angles becomes a pivotal part of the larger picture of disabled children's mobility experiences.

Over the past decade, there has been a rapid increase in pediatric mobility research, and a growing body of evidence demonstrating physical and psychosocial efficacy of early powered mobility technology use (Casey, Paleg, & Livingstone, 2013; Jones, McEwen & Neas, 2012; Livingstone & Paleg 2014; Rodby-Bousquet & Hägglund, 2010; Uchiyama et al., 2008). However, recognition of these benefits, at least among researchers and clinicians, has not necessarily resulted in a concomitant increase in access to, or utilization of, mobility technology for disabled children (Guerette, Tefft, & Furumasu, 2005; Livingstone & Paleg, 2014; Rodby-Bousquet & Hägglund, 2010). Child and family experiences and perceptions are likely one factor contributing to this finding, which further underscores the importance of this issue, however, relatively few studies have considered caregiver and child perceptions of their mobility devices.

Even less is known about their perceptions of these practices within an alternative provision system. Over the past five years, researchers have revisited innovative early mobility solutions piloted in the 1980's, with the modification of commercially available, inexpensive, plastic battery-powered ride-on toy cars as an early, non-medical form of powered mobility for disabled infants and toddlers (Huang & Galloway, 2012). The Go Baby Go project has received ongoing funding support to continue studying the feasibility of this design with populations not typically considered for powered mobility, technical aspects of design that allow driving from multiple positions, and community use of the cars in conjunction with other mobility solutions (Huang & Galloway, 2012; Logan, Huang, Stahlin, & Galloway, 2014). While promising traditional child and family related outcomes have been reported, there has not been, to date, a focus on the family involvement with the modification process, or on the family perceptions of the cost, aesthetic, and accessibility profile of the ride-on cars. These factors are worthy of further exploration.

Methods

This study was conducted using an ethnographic case study approach, where two alternate cultures of mobility technology provision and early use were examined using a combination of qualitative and participatory action methods, including in-depth semi-structured interviews, field observations, document analysis, and photovoice narrative. 21 people participated in the study, including two children and their families, their clinicians, and 10 key informants from the powered mobility industry, who held roles in company leadership, clinical services, education consulting, marketing, manufacturing, design engineering, and research and development. One child and family pursued a traditional powered wheelchair through a professional seating clinic, and the other pursued a modified Go Baby Go ride-on car that was built in the community by a group of volunteers and professionals. Each child and family was followed across a three to four-month period of engagement, where data was gathered at and around three key events: 1) The initial seating evaluation/pre-build consultation; 2) the delivery appointment/ride-on car build; and 3) a one to two-month follow up visit. Data collected was transcribed, coded, and analyzed using the constant comparative method in a case-wise manner to determine the major themes that emerged from the participants' experiences. A cross-case appraisal was also conducted to compare similar and dissimilar thematic instances.

Findings

Four major themes and three higher-order constructs emerged from the data. First, Dys/Function of Mobility Technology comprised aspects of each family's experience relating to device disrepair; practical or abstract perceptions of the role of the device; concerns about safety and security; and concerns with the size/weight footprint of the device. Second, Daily Life, Play, and Participation, captured experiences of daily activity and interaction with peers and siblings; perceptions of participation with and without mobility technology; concerns about accessible and inaccessible environments; and varying attitudes of others. Third, Emerging Self/Advocacy related to how families defined and promoted independence; seeking out mobility opportunities; setting one's own mobility agenda; and expressing creativity about device design and features. Finally, Complex Family/Industry Interplay explored each family's experience with industry related to choice-making; expectations and formality of provider interactions; provider knowledge; device costs and aesthetics; and provision hassles.

This data was further synthesized into three higher-order constructs that encapsulated what the provision and early use process was ultimately about for these families: participation, expectation, and identity. These conceptual categories were abstracted from each theme in slightly different ways, but remained omnipresent as the families navigated their experiences. For example, participation was facilitated or hindered by dys/function of the mobility device (Theme 1), others' attitudes and perceptions (Theme 2), the confidence of the child in setting a mobility agenda (Theme 3), or the choices and aesthetics offered by the industry for mobility technology consumers (Theme 4). Similarly, expectation related to a caregiver's expectation of the mobility device itself (Theme 1), the child's expectations in exploring play and participation (Theme 2), a caregiver's expectations of their child (Theme 3), or caregiver expectations of industry support (Theme 4). Further, the collective experiences and perceptions within these themes, as well as the devices and cultures of provision themselves, are not neutral, and thus will help shape the identities of both children into the future.

Discussion

As two families experienced two different cultures, or models, of powered mobility provision and early use, in some cases each family shared similar experiences, such as common fears for safety and security, comparable appraisals of the positive effects of mobility technology on their sons' participation, similar perceptions of provision or accessibility hassles, and similar concerns over device cost and size. Yet in some cases, such as the mothers' perceptions of powered mobility industry professionals, or their conceptualization of independence and disability, they differed dramatically.

For example, the family who received the powered wheelchair felt that knowledge or bias of professionals, who were making decisions about expensive equipment in a relatively short time without knowing their son well, was a limiting factor. Contrastingly, the family who received the ride-on car felt that the knowledge of the professionals and volunteers who built the ride-on car with them, some of whom knew their son well, and some of whom had expertise in the modification

process, was a facilitating factor. One family looked upon the powered wheelchair as an opportunity for independence, and promoted a positive disability identity by seeking out successful kids and adults who use powered mobility to act as role models for their son. The other family also appreciated the freedom and opportunity afforded by the ride-on car, but saw it as just one of many modes of mobility that complimented walking as their primarily desired mode for their son, who they referred to as a 'walking man'. They saw the ride-on car as a 'cool' way to be different, and retained their perception of a wheelchair as an unwelcome signifier of disability. In fact, having the ride-on car as an aesthetically alternative powered mobility option strengthened the family's resolve to forestall their son's potential need for a wheelchair in the future.

However, even though caregiver perceptions diverged, the experiences shared by the boys throughout their first encounters with powered mobility were markedly parallel. Both boys described aspects of their devices that they did and did not like, and both experienced conscious changes in their participation as well as changes in their emerging agency that were mediated by the respective devices. Both boys also experienced similar accessibility limitations in certain play situations, and both devices were interesting and coveted by their peers, although this was a much more common occurrence for the boy with the ride-on car. These similarities occurred despite their respective mobility technologies and provision processes being quite unique. Although the devices themselves did appear to influence the children's and family experiences, it was not the principal influence. Rather, it was the perceptions and expectations of the family that primarily shaped their mobility experience. Finally, informants from both the powered mobility industry as well as the toy industry offered their insights into industry processes such as funding and regulatory oversight, niche marketing opportunities to disabled children and their families, challenges with innovation and design, and the struggle to balance altruistic aims with for-profit business structure. These are important influences that, as part of the disability business, help shape the experiences of children and families as consumers.

Conclusion

The findings from this study have the potential to inform multiple stakeholders in the powered mobility provision process. The data suggests that experiences and perceptions of children and families about disability, the devices themselves, and the processes to obtain them act as a direct influence on the identity development of young children as powered mobility users and disabled people. Whether this identity is internalized as positive or negative depends on both the implicit and explicit messages a child receives during these processes. The findings indicate that for these participants, the mobility technology provision process, along with the early use of a mobility device, is not a simple procurement transaction. Rather, it is a social, emotional, and practical endeavor for both caregiver and child, in fulfillment of the right to self-directed mobility.

References

1. Borg, J., Larsson, S., & Ostergren, P. (2011). The right to assistive technology: For whom, for what, and by whom? *Disability & Society*, 26(2), 151-167.
2. Casey, J., Paleg, G., & Livingstone, R. (2013). Facilitating child participation through power mobility. *The British Journal of Occupational Therapy*, 76(3), 158-160.
3. Charlton, J. I. (1998). *Nothing about us without us: Disability oppression and empowerment*. University of California Press.
4. Gibson, B. E., & Teachman, G. (2012). Critical approaches in physical therapy research: Investigating the symbolic value of walking. *Physiotherapy Theory & Practice*, 28(6), 474-484.
5. Gibson, B. E., Teachman, G., Wright, V., Fehlings, D., Young, N. L., & McKeever, P. (2011). Children's and parents' beliefs regarding the value of walking: Rehabilitation implications for children with cerebral palsy. *Child: Care, Health and Development*, 38(1), 61-69.
6. Gudgeon, S., & Kirk, S. (2015). Living with a powered wheelchair: exploring children's and young people's experiences. *Disability and Rehabilitation: Assistive Technology*, 10(2), 118-125.
7. Guerette, P., Tefft, D., & Furumasu, J. (2005). Pediatric powered wheelchairs: results of a national survey of providers. *Assistive Technology*, 17(2), 144-158.
8. Huang, H., & Galloway, J. C. (2012). Modified ride-on toy cars for early power mobility: A technical report. *Pediatric Physical Therapy*, 24(2), 149-154.
9. Jones, M. A., McEwen, I. R., & Neas, B. R. (2012). Effects of power wheelchairs on the development and function of young children with severe motor impairments. *Pediatric Physical Therapy*, 24(2), 131-140.
10. Kielhofner, G. (2005). Rethinking disability and what to do about it: Disability studies and its implications for occupational therapy. *American Journal of Occupational Therapy*, 59(5), 487-496.
11. Livingstone, R., & Paleg, G. (2014). Practice considerations for the introduction and use of power mobility for children. *Developmental Medicine & Child Neurology*, 56(3), 210-221.
12. Logan, S. W., Huang, H., Stahlin, K., & Galloway, J. C. (2014). Modified ride-on car for mobility and socialization: Single-case study of an infant with down syndrome. *Pediatric Physical Therapy*, 26(4), 418-426.
13. Mortenson, W. B., & Miller, W. C. (2008). The wheelchair procurement process: Perspectives of clients and prescribers. *Canadian Journal of Occupational Therapy*, 75(3), 167-175.
14. Nicholson J, & Bonsall M. (2005). Powered mobility for children under five years of age in England. *The British Journal of Occupational Therapy*, 65(6), 291-293.
15. Ripat, J., & Woodgate, R. (2011). Locating Assistive Technology within an emancipatory disability research framework. *Technology and Disability*, 23(2), 87-92.
16. Rodby-Bousquet, E., & Hägglund, G. (2010). Use of manual and powered wheelchair in children with cerebral palsy: A cross-sectional study. *BMC Pediatrics*, 10(59), 1-8.
17. Siebers, T. (2008). *Disability theory*. Ann Arbor, MI: University of Michigan Press.
18. Uchiyama, I., Anderson, D. I., Campos, J. J., Witherington, D., Frankel, C. B., Lejeune, L., & Barbu-Roth, M. (2008). Locomotor experience affects self and emotion. *Developmental Psychology*, 44(5), 1225-1231.
19. Wiart, L., Darrah, J., Hollis, V., Cook, A., & May, L. (2004). Mothers' perceptions of their children's use of powered mobility. *Physical and Occupational Therapy in Pediatrics*, 24(4), 3-21.

IC07: Postural and Functional Benefits of Power Wheelchair Operation at Midline

Russ Rolt

Session Description

This 75 minute course will thoroughly cover the myriad benefits of driving power wheelchairs from a midline position. A lively and entertaining powerpoint presentation will accompany Russ Rolt, VP Sales and Business Development at Active Controls, as he discusses the postural benefits, functional benefits and the improved control and operation when driving a power wheelchair from midline. Midline driving has been proven to offer multiple functional and postural benefits to the end user. Therapists can optimize their client's function, improve client posture and increase the overall success of power chair provision by embracing this concept.

Russ Rolt's presentation style drills down on a complex subject in a way that makes it easy to understand but does not short-change the science behind the technology. His professional background as a former ATP provides a keen insight into the subject matter with an energetic and medically accurate delivery that is very relatable to a wheelchair clinician.

This presentation is divided into four sections: Historical Background, Clinical Advances, Pro's and Con's of Midline Driving, and Alternative Drive Controls at Midline. Notes from the powerpoint will be provided to all attendees, as well as a copy of "Prevent and Amend Muscular Skeletal Conditions" which presents a leading physiatrist's research on the biomechanical advantages of midline driving of study and a certified ergonomic assessment specialist's findings on improved posture and pressure distribution.

The first section of the presentation provides a brief historical background that highlights how midline is the natural/preferred location for steering a moving vehicle. This background shows how the evolution of the power wheelchair deviated from midline over the course of time. It also covers the history of alternative mounts used to make midline possible and the limitations that have kept them from being more widely utilized.

The second section presents a clinical discussion of the advances that midline driving makes possible. The attendee will learn more about proprioception, pressure distribution, spacial awareness and balanced posture in regards to midline vs armrest mounted drive controls. The different muscle groups used for each drive position will also be discussed in this section.

The third section dives into the pros and cons of midline driving as it can be achieved through gatin mounts, trays, and the center drive system. Covering all of the current methods

to achieve midline, this section of the presentation thoroughly and objectively lists the benefits and disadvantages of all the methods to achieve midline with a client. The client-based focus of how this section is presented can provide a real value for the attendee in real-world applications of midline mounting technologies.

The last and largest section of the presentation touches on each of the many types of alternative drive controls that can be deployed optimally at midline. It also explains the ergonomics behind the posture enabled at midline. Proportional, micro-proportional, capacitive, and proximity based drive controls are all devoted equal attention in this section. The technology presented here is explained with an appropriate depth that comes across in a clear and concise manner without succumbing to the pitfall of information overload. This highly educational portion of the presentation offers real take-home for today's clinician.

Finally, the session concludes by re-focusing on midline driving from the perspective of each client's unique needs. The attendee will walk-away with a comprehensive understanding of the benefits of the midline driving concept on an individual client level. The overall goal of the presentation is for clinicians to appropriately consider midline driving for their clients and still retain the conventional tools used during assessments to find success and drive greater outcomes.

Outcome Learning Objectives

Upon completion of this session, attendees will be able to:

- Describe the importance of the position of the drive control and how it contributes to posture.
- Demonstrate the importance of the position of the drive control and how it contributes to pressure distribution.
- Demonstrate the importance of secondary upper extremity support while driving at midline.
- Compare and contrast the pro's and con's of midline mounting methods.
- List the various types of alternative drive controls available at midline.
- Discuss improved orientation in space from driving at midline.
- Discuss fatigue reduction achieved from driving at midline.
- Discuss the positive ergonomic contribution from midline driving.

Content References

1. Adequacy of power wheelchair control interfaces for persons with severe disabilities: A clinical survey, Linda Fehr, MS; Edwin Langbein, PhD; Steven B. Skaar, PhD, Journal of Rehabilitation Research and Development, Vol.37, No.3, May/June 2000, Pages 353-360.
2. Proportional Control for Power Wheelchairs, Michelle L. Lange, Advance Occupational Therapy Practitioners, Vol 26, Issue 10, page 13, 2010.
3. Joystick Control for Powered Mobility: Current State of Technology and Future Directions, Brad E. Dicianno, MD, Assistant Professor, Rory A. Cooper, PhD; John Coltellaro, MS, ATP, Rehabilitation Engineer, Phys Med Rehabil Clin N Am. Feb 2010; 21(1): 79–86.

Content Outline

- Welcome, Introductions, & Course overview
5 minutes
- Historical Background; Lecture/PowerPoint
10 minutes
- Clinical Advances; Discussion/PowerPoint/Handout on Research Study
15 minutes
- Pros and Cons of Midline Driving; Lecture/PowerPoint/
Demonstration of Controls
10 minutes
- Alternative Drive Controls at Midline; Lecture/PowerPoint/
Demonstration of Controls
20 minutes
- Conclusion; Lecture/PowerPoint
10 minutes
- Questions and Discussion
5 minutes

Instructional methods:

Instruction will include pictures and power point presentation.

Speaker Biography

Russ Rolt has been working for Active Controls since April 2011 and is highly experienced professional with nearly 30 years experience in the Complex Rehab industry as a provider and working in product development of medical devices. He has participated in all facets of the industry. Beginning in sales then management to the creation of his own company specializing in Complex Rehab products in 1998. In his current position as Vice President of Active Controls, Russ has been integral in the design and development of the Active Controls Center Drive System. This experience and his work with thousands of doctors and clinicians worldwide has been the validation of the functionality of the midline concept. He has a keen interest in innovation in the mobility market and has been involved in designing innovative solutions for several hundred complex rehab clients.

Conflict of Interest Disclosure

Russ Rolt is employed by Active Controls LLC.

Session Level

Instructional level- Intermediate

Keywords

- Complex Rehab
- Drive Controls
- Alternative Drive Controls
- Switched Driving
- Midline Driving
- Alternative Input Device
- Power

IC08: Development of Wheelchair Standards for Less-Resourced Settings

Anand Mhatre, MIMSE

Jon Pearlman, PhD

Introduction

Wheelchairs provided in less-resourced settings fail prematurely as they are subjected to demanding outdoor environments and use conditions. Wheelchair failures in the field are known to cause injuries to users and breakdowns have adverse effects on the quality of life. For this reason, the guidelines on provision of manual wheelchairs developed by World Health Organization promote ISO 7176 testing of wheelchairs and further encourage conducting additional quality testing based on the conditions experienced in less-resourced settings. However, there are no clear directions on design and development of such additional testing standards. The International Society of Wheelchair Professionals (ISWP) undertook the initiative for developing additional wheelchair tests and the instructional course will cover the steps taken by ISWP Standards Working Group in developing the new tests for less-resourced settings. The course will also describe other tools and resources that are developed by ISWP for raising the quality of wheelchairs worldwide. Methods: Identifying the additional tests needed was accomplished in two ways. First, a literature review of development of ISO standards, wheelchair testing studies and failures seen in less-resourced environments was performed. Second, expert advice from members of the Standards Working Group of the International Society of Wheelchair Professionals was compiled and reviewed. The outcomes of the review and expert advice provided directions on development of different types of additional wheelchair tests.

Results

Development of International Standards

ISO work commenced in the early 1980's with participation from UK, Sweden, Germany, France, Denmark, US, Canada, Austria and Japan (Cooper et al. 1996; McLaurin 1986; Staros 1981), but no LREs were involved. There are now 34 standards published by the committee with expanded categories that include power wheelchairs, scooters, and stair-climbing devices. ISO 7176 standards tests consist of durability, safety and performance tests along with measurement and reporting of wheelchair dimensions and characteristics. Some test procedures allow for comparison between wheelchair safety and performance while certain tests need the wheelchair to pass minimum requirements (number of test cycles) (Cooper et al. 1996; Hobson 1999). ISO 7176-8 includes tests for strength, impact and fatigue. Fatigue tests consist of a multi-drum test (MDT) and curb-drop test (CDT) conducted in a

controlled laboratory setting and for passing minimum ISO requirements, products should complete 200,000 MDT cycles and 6666 CDT drops without failures (Hobson, 1999) which is supposed to represent 3-5 years of use.

Literature Review Results

Twelve articles related to ISO 7176 testing were found and reviewed. Two studies provided results on testing on wheelchairs used in LREs that failed early on multi-drum testing. New-condition wheelchair models were evaluated in these studies that were already available on the market and commonly purchased. Ultralight-weight wheelchairs experienced higher Class I failures that could be repaired by users whereas hospital-style wheelchairs had greater Class III failures (Fitzgerald et al. 2001). Failures with cross-braces, side frames (at weld joints) and back rests, caster forks and spindles, and footrests were noted. There was no evidence found in these studies that correlated performance of wheelchairs on ISO laboratory tests with outdoors use and LRE conditions. Also, none of these testing studies matched type of failures on fatigue tests with field failures.

Evidence of Field Failures in LREs

Seven articles were found that evaluated wheelchair usability in the LRE community. Based on anecdotal and research evidence, majority of the wheelchair designs distributed in LREs cannot endure outdoor conditions and fail prematurely (Constantine et al. 2006; Kim & Mulholland 1999; Mulholland et al. 2000; Mukherjee & Samanta 2005; Saha et al. 1990; Sheldon & Jacobs 2006; Toro et al. 2012, 2013). Several wheelchair failures and performance issues with brakes, casters, rear wheels and other parts were noted in these studies.

Expert Advice from ISWP-SWG members

Photographic evidence was provided by ISWP-SWG members on field failures of wheelchair parts. They reported minimal LRE participation in ISO 7176. ISWP-SWG members identified some unique quality-affecting elements such as corrosion, aging and high impact forces (e.g. if a wheelchair is dropped from a bus) as causes for wheelchair failures. Durability issues with parts like upholstery, anti-tippers, belt harness, calf straps, toe straps and fasteners were noted as durability issues that are not tested under ISO 7176.

Additional Test Methods Identification

A product testing matrix (Table 1) was developed that listed parts, failure modes (as noted by experts), testing priority and the applicability of ISO test methods for each failure mode. The testing priority for different parts was assigned by a consensus from ISWP-SWG members based on the parts that fail most often and make the wheelchair non-functional. Based on votes, casters and rear wheels were selected as crucial components for testing. Corrosion testing of parts and testing complete wheelchair through simulated environmental conditions were prioritized as well.

Components	Failure modes	Test factors	Priority	ISO test methods
Casters, Rear Wheels & Bearings	Tire type, wheel and caster features, and bearings affect rolling resistance.	Rollability: Effort required to propel wheelchairs on paved and unpaved surfaces	High	Not in ISO 7176
	Broken caster and wheel parts.	Durability: impacts and loads; fracture loads		Yes (ISO 7176 – 8), but does not reproduce complex load conditions that occur in LRCs.
	Worn out tires	Durability: abrasion		Not in ISO 7176
	Parts degradation	Durability: accelerated aging		Not in ISO 7176
	Corroded bearings and metallic parts	Durability: corrosion		Not in ISO 7176
	Fluttering caster may waste effort and cause accidents	Caster flutter		Seen on ISO 7176-8 multi-drum test but not tested for.
	Tire puncture	Test for air retention for wheels, puncture tests		Not in ISO 7176
	Worn out bearings, dirt and dust in bearings	Test lubrication quality, seal design & quality		Not in ISO 7176
Trueness of wheels over time is affected, camber issues	Wheel alignment	Not in ISO 7176		
Seat Cushion & Upholstery	Seat cushions flatten over time.	Durability: cushion compression	High	Not in ISO 7176
	Exposure to fluids causes deterioration	Chemical resistance & Waterproof testing		Not in ISO 7176
	Tearing and wearing of cushion and cover, loosening upholstery	Durability: aging, tearing, abrasion, loosening		Not in ISO 7176
Wheel Locks	Loosening and corrosion of locks	Durability: cyclic testing, aging, corrosion	Low	Not in ISO 7176
Footrest	Broken footrests	Durability: strength	High	ISO 7176 – 8
	Difficulty in folding, adjusting for height	Durability: corrosion		Not in ISO 7176
Frame and cross braces	Bent push handles	Durability: loading	Low	Not in ISO 7176
	Wear on coatings, coating deterioration	Paint chipping and corrosion		Not in ISO 7176
	Rusted holes, welds, and areas where paint is chipped off	Durability: corrosion & testing folding mechanism		Not in ISO 7176
Fasteners & Arm Pads	Bolts and pads loosen out	Loosening	Low	ISO 7176 – 8
	Pads deteriorate, exposing edges	Aging and abrasion testing		Not in ISO 7176
	Rusted components	Durability: corrosion		Not in ISO 7176

tests – MDT and CDT are insufficient for testing for corrosion fatigue or predicting corrosion effects. Thus, product testing with ISO 7176 methods and development of test methods that replicate LRE conditions for additional testing was recommended by ISWP-SWG members. Following this recommendation and additional test method identification by experts, ISWP has developed test equipment for caster testing and rolling resistance testing. Caster durability and rolling resistance of the wheelchair will be tested on different surfaces. Corrosion testing will be conducted in a salt fog chamber as per ASTM B117 standard. The team is currently developing tests for whole-chair testing through different simulated conditions as found in LREs. Following development of test methods, the group plans to integrate new test methods into ISO standards as a new or add-on standard to ISO 7176 or as a technical specification so that they are harmonized with national standards. The group aims to develop test protocols for the newly developed tests and conduct field validation.

Table 1: Product Testing Matrix

Conclusions

Discussion

Based on the review of ISO standards development and experience of the ISWP-SWG members who participate on the ISO committee, there is little representation from LREs, and consequently no test factors representing unique conditions in these environments are evident in the standards. Wheelchairs produced in LREs and hospital-style chairs (similar designs are donated in LREs) failed prematurely on the multi-drum tests and need to be of greater quality to perform in LRE environments. Mixed outcomes were related to wheelchair models that were donated in LREs. Findings indicate that there is a disconnect between the product (design & quality) and environmental conditions which is responsible for performance issues and failures in LREs. Despite this fact, no indications or directions for additional durability testing were found in these studies. ISO 7176 may be sufficient to screen wheelchairs that will failure extremely quickly but there is no evidence that the tests accurately reproduce failures that occur on more durable products that last the anticipated 3-5 years. Photographic evidence by experts demonstrate the nature and extent of deterioration in quality that products experience in LRE environments. Corroded casters and brakes from ISO certified wheelchairs were reported to be non-functional after 15 months of use. Experts indicated that ISO fatigue

The goals of this work were to identify the additional wheelchair tests necessary to screen products for LREs as suggested by the WHO guidelines and Wheelchair Consensus Conference. Published evidence combined with field observations by ISWP-SWG experts indicate that wheelchairs fail in LREs in ways that would not be predicted by ISO 7176. Additional test methods are required that incorporate test factors responsible for the diverse failures seen in LREs. The additional tests that were identified include testing for corrosion/degradation due to the environmental conditions, rolling resistance, caster durability, and whole-chair testing.

References

1. Constantine, D., Hingley, C. A., & Howitt, J. (2006). Donated wheelchairs in low-income countries - issue and alternative methods for improving wheelchair provision. <http://doi.org/10.1049/ic.2006.0658>
2. Cooper, R. A., Gonzalez, J., Rick, B. S., Robertson, R. N., & Boninger, M. L. (1996). New developments in wheelchair standards. In Proceedings of 18th Annual International Conference of the IEEE Engineering in Medicine and Biology Society (Vol. 5, pp. 2191–2192). IEEE. <http://doi.org/10.1109/IEMBS.1996.646491>
3. Fitzgerald, S. G., Cooper, R. A., Boninger, M. L., & Rentschler, A. J. (2001). Comparison of fatigue life for 3 types of manual wheelchairs. *Archives of Physical Medicine and Rehabilitation*, 82(10), 1484–8. <http://doi.org/10.1053/apmr.2001.26139>
4. Hobson, D. A. (1999). Development and Application of Wheelchair Standards: Everything most people want to know in 30 minutes or less! In RERC on Wheeled Mobility. Pittsburgh, PA.
5. Kim, J., & Mulholland, S. J. (1999, January 1). Seating/wheelchair technology in the developing world: need for a closer look. *Technology and Disability*. IOS Press. Retrieved from <http://content.iospress.com/articles/technology-and-disability/tad00025>
6. McLaurin, C. A. (1986). Wheelchair development, standards, progress, and issues: A discussion with Colin McLaurin, Sc.D. *Journal of Rehabilitation R&D*, 23(2), 48–51. Retrieved from <http://www.scopus.com/inward/record.url?eid=2-s2.0-0022707389&partnerID=tZOtxy1>
7. Mukherjee, G., & Samanta, A. (2005). Wheelchair charity: a useless benevolence in community-based rehabilitation. *Disability and Rehabilitation*, 27(10), 591–6. <http://doi.org/10.1080/09638280400018387>
8. Mulholland, S. J., Packer, T. L., Laschinger, S. J., Lysack, J. T., Wyss, U. P., & Balaram, S. (2000). Evaluating a new mobility device: feedback from women with disabilities in India. *Disability and Rehabilitation*, 22(3), 111–122. <http://doi.org/10.1080/096382800296962>
9. Saha, R., Dey, A., Hatoj, M., & Podder, S. (1990). Study of wheelchair operations in rural areas covered under the District Rehabilitation Centre (DRC) scheme. *Indian Journal of Disability and Rehabilitation*, (Jul-Dec), 57–87.
10. Sheldon, S., & Jacobs, N. A. (2006). Report of a consensus conference on wheelchairs for developing countries. Retrieved from <http://www.who.int/disabilities/technology/WCGconsensusconf/en/#.Va2QwYdvWAl.mendeley>
11. Toro, M. L., Garcia, Y., Ojeda, A. M., Dausey, D. J., & Pearlman, J. (2012). Quantitative Exploratory Evaluation of the Frequency, Causes and Consequences of Rehabilitation Wheelchair Breakdowns delivered at a Paediatric Clinic in Mexico. *Disability, CBR & Inclusive Development*, 23(3), 48–64. <http://doi.org/10.5463/dcid.v23i3.167>
12. Toro, M. L., Garcia-Mendez, Y., Dausey, D. J., & Pearlman, J. L. (2013). Comparison of a manual wheelchair designed and produced in Mexico to a wheelchair produced in China based on ISO testing and clinician and user feedback. In Proceedings from the Rehabilitation Engineering and Assistive Technology Society of North American Annual Conference. Bellevue, Washington.

PS1.1: Health Outcomes of Wheelchair Seated Posture

Lelia Barks, PhD, ARNP

Barbara Crane, PhD, PT

Cynthia Garvan, PhD

Matthew Peterson, PhD

Lisa Brown, PhD

Gail Powell-Cope, PhD, ARNP

Background

We posit that wheelchair seated posture is predicted by and mediates certain health outcomes (Lin, et al, 2006) as reflected in the following model:

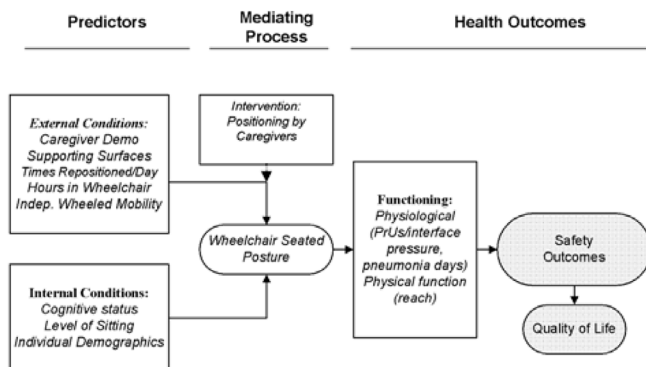

Posture is difficult to measure, because it is dynamic; however, in order to understand outcomes of wheelchair seating, it is necessary to measure and account for the effect of wheelchair seated posture on outcomes. The specific aims of this correlational, observational study were to : 1) Describe changes in wheelchair seated posture of older Veterans in the CLC environment over the course of a day; 2) Determine if there is an association between wheelchair seated posture of older Veterans in the CLC environment and posited predictors (supporting surfaces, times repositioned/day, time in wheelchair, cognitive status, independent wheeled mobility (), and level of sitting ability); and 3) Determine if there is an association between wheelchair seated posture of older Veterans in the CLC environment and intermediate and long term outcomes (interface pressure, pressure ulcer incidence, discomfort/pain, functional reach , and days of Health Care Acquired Pneumonia).

Methods

We included 45 Veterans over age 62 who sit in a wheelchair daily for 5 hours, for periods of at least 2 consecutive hours. We excluded Veterans with spinal cord injury, amputees, those with BMI over 35, and those with open pressure injuries on the seating surface areas. We collected data at four time points over the day: upon arising, two hours later, in midafternoon, and two hours later. Participants were out of the wheelchair for two hours after lunch. FSA BodiTrak pressure mapping mats were placed under participants for the two hour morning and afternoon periods, measured at start and end of the period. Creep was controlled within the FSA software. We used Peak Pressure Index (Sprigle et al., 2003; Brienza et al., 2010) to measure interface pressure.

Findings

Final results are forthcoming, pending journal submission.

References

1. Brienza, D., Kelsey, S., Karg, P., Allegretti, A., Olson, M., Schmeler, M., Zanca, J.,
2. Geyer, M., Kusturiss, M., & Holm, M. (2010). A Randomized Clinical Trial on Preventing Pressure Ulcers with Wheelchair Seat Cushions. *Journal of the American Geriatrics Society*, 58(12), 2308–2314. <https://doi.org/10.1111/j.1532-5415.2010.03168.x>
3. Kirby R. L., Smith C., Parker K., McAllister M., Boyce J., Rushton P. W., Routhier F., Best K. L., MacKenzie D., Mortenson B., Brandt A. (2016). *The Wheelchair Skills Program Manual Version 4.3*. Halifax, Nova Scotia: Dalhousie University. Retrieved from http://www.wheelchairskillsprogram.ca/eng/documents/version4.3.3/The_Wheelchair_Skills_Program_Manual_77_w_comments_and_highlights.pdf
4. Lin, F., Parthasarathy, S., Taylor, S. J., Pucci, D., Hendrix, R. W., & Makhsous, M. (2006). Effect of Different Sitting Postures on Lung Capacity, Expiratory Flow, and Lumbar Lordosis. *Archives of Physical Medicine and Rehabilitation*, 87(4), 504–509. <https://doi.org/10.1016/j.apmr.2005.11.031>
5. Sprigle, S., Dunlop, W., & Press, L. (2003). Reliability of bench tests of interface pressure. *Assistive Technology : The Official Journal of RESNA*, 15(1), 49–57. <https://doi.org/10.1080/10400435.2003.10131889>

This study was supported by a Veterans Health Administration Rehabilitation Research & Development Service Career Development Award-2.

PS1.2: Developing a Seating Intervention for Older Veterans

Lelia Barks, PhD, ARNP

Lisa Brown, PhD

Gail Powell-Cope, PhD, ARNP

Background

Positioning of nursing home residents in wheelchairs is a nursing task that is often delegated to Certified Nursing Assistants (CNAs). Positioning older adults in wheelchairs can affect comfort, interface pressure, and performance of functional tasks. (Trefler, et al., 2010). In nursing homes (community living centers, or CLCs), nursing staff may face barriers to positioning individuals correctly in wheelchairs. The best wheelchair in the world is worth little to a person inappropriately positioned in it. The purpose of this qualitative study was to identify barriers, facilitators, and shared practices of correct wheelchair positioning, in one VA CLC, to later develop an intervention (Nastasi & Schensul, 2005) to include the CLC staff.

Methods

We conducted focused interviews (n=28), using purposive snowball sampling of direct care providers of wheelchair positioning: nursing assistants, licensed practical nurses, registered nurses, and kinesiotherapists. Data were placed into Atlas.ti software 7.1.7 and coded using content analysis with concurrent memoing (Creswell, 2014). Codes were synthesized into themes and reliability checked by two other investigators (Creswell & Miller, 2000).

Findings

Facilitators of positioning Veterans in wheelchairs were: higher quality equipment (wheelchairs with mechanized “tilt”); sufficient staffing; the interdisciplinary team process, specific CLC practices, and training. Barriers to positioning were: physical factors (equipment and logistics), Veteran condition (pain, toileting needs, behavioral tendencies or preferences, diagnosis,) and insufficient staffing. Staff identified skin breakdown as an outcome of poor seating. Only two staff had received any formal training in positioning residents in wheelchairs.

Conclusion

Staff identified facilitators as resource issues (adequate staffing, equipment and training). These factors became barriers when absent or of poor quality. These data were used to develop a seating intervention.

References

1. Creswell, J. W. (2014). *Research Design: Qualitative, Quantitative, and Mixed Methods approaches*, 4th ed. (pp. 183-220). Los Angeles, CA: Sage.
2. Creswell, J. W., & Miller, D. L. (2000). Determining Validity in Qualitative Inquiry. *Theory Into Practice*, 39(3), 124–130. https://doi.org/10.1207/s15430421tip3903_2
3. Nastasi, B. K., & Schensul, S. L. (2005). Contributions of qualitative research to the validity of intervention research. *Journal of School Psychology*, 43(3), 177–195. <https://doi.org/10.1016/j.jsp.2005.04.003>
4. Trefler, E., Fitzgerald, S. G., Hobson, D. A., Bursick, T., & Joseph, R. (2004). Outcomes of Wheelchair Systems Intervention With Residents of Long-Term Care Facilities. *Assistive Technology*, 16(1), 18–27. <https://doi.org/10.1080/10400435.2004.10132071>

This study was supported by a Veterans Health Administration Rehabilitation Research & Development Service Career Development Award-2.

PS1.3: The Experience of Spinal Cord Injury and Wheelchair Use

Jenny M. Lieberman, PhD, OTR/L, ATP

Introduction

The purpose of this phenomenological study was to understand how three people with spinal cord injury experience their lives, their bodies, and their lifeworld through wheelchair use. Because of accountability and reimbursement requirements, physicians, clinicians, and wheelchair providers tend to focus on the client's diagnoses and impairments rather than the person or the role the wheelchair plays in his or her life. In order to provide more effective rehabilitation services and interventions, Professionals need to understand the lived experiences of a person with spinal cord injury. In this phenomenological study, I endeavored to understand what meaning three people who experienced spinal cord injury attached to their lives and the need to use a wheelchair for mobility. While people with spinal cord injury may share a loss of motor function and have a common need to use a wheelchair, the manner in which each person experiences these phenomena is different. How he or she perceives his or her lifeworld is personal. Each person has a distinct story to tell. Understanding individual stories provides a deeper understanding of the human experience for a person who lives his or her life using a wheelchair. Further, these stories help people in the medical profession to better understand and more appropriately respond to patients who have this experience.

Methodology

This study used phenomenology as the backbone for analysis and explication of results. Phenomenon is whatever appears to us in consciousness. Phenomena are therefore the building blocks of our social reality and as such the basis of all knowledge (Moustakas, 1994). In phenomenology, the aim of the researcher is to describe the phenomena as accurately as possible, while remaining true to the participant's story (Groenwald, 2004).

Embodied experience is a central theme of phenomenology, examining the perceptive awareness within our body as our body experiences the world (Gallagher, 2000). Focusing on embodied experience, the phenomenological approach allows the researcher to understand how people subjectively experience their lives, by examining participants bodily sensations, feelings, and reactions to the experience (Davidson, 2000; Willis, Willis, Jost, & Nilakanta, 2007). This is described as the lifeworld. In phenomenology, attention is paid to how the subjective body (the individual's view of their body) and the objective body (the body as parts) are intertwined with the world (Finlay, 2006).

What distinctions do people with spinal cord injury make between their body and their new reliance upon a wheelchair? Is the wheelchair an extension of the body or a part of it? Or is it something else? Merleau-Ponty (2002) emphasized that things can be an extension of the body. Since objects such as wheelchairs are an interface between the person and their environment, could they therefore be considered an extension of the person? What do well-known spaces, such as stairs in the home, mean to the lived body as it moves through a once familiar environment in a wheelchair? After disability, the relationship between the lived body and space changes, and tasks once so simple, such as toileting and dressing, can be altered depending on the task and the extent of disability (Petterson, et al., 2007).

Findings and Discussion

Each participant in this study experienced their spinal cord injury and altered mobility as well as their lives before and after injury differently. Yet for all three, there were certain things that aided in their rehabilitation process and certain things that did not. Their stories provide important insight into spinal cord injury as an embodied experience and reveals how therapist, families and friends can hinder or enhance the healing process.

All three participants expressed the feeling of being objectified. This was a combination of social construction and therapist expectation based upon prior experience. Society fosters the presumption that people with a disability are "not normal." Structural and social barriers to participation play heavily into meaningful existence for people with disabilities because of wheelchair use (Moola & Norman, 2012, p. 285). Robert Murphy (1987) reiterated this when discussing his life with a spinal cord injury, noting that along with the neural loss that occurs within the body, there is a loss of one's previous identity. This loss is one of "societal isolation" (Murphy, 1987, p. 227). Removing the idea that the patient is no longer "normal" can help them consciously conceive of a new way of being in his or her changed body.

The sense that therapists had to follow a protocol for intervention did not motivate the participants in this study. Not only did they feel it did not create an environment to learn how to live in their newly transformed bodies, but the participants also felt the therapists did not understand what they were going through nor did they try. Acknowledging that one cannot know what the person with spinal cord injury is thinking or going through allows for the opportunity to explore their needs, fears and concerns together. Treating the patient with spinal cord injury is not just about treating the spinal cord injury, but rather it is treating the person holistically. As a result, therapists must understand and address the emotional aspects of spinal cord injury as well as the physical. The three participants in this study verbalized that there were frequent points where they felt they were not heard or understood during therapy, resulting in feeling scared and at times completely out of control. When this occurred, they did not want to participate in therapy, thereby creating a negative view of rehabilitation. Since patients are better able to verbalize their sense of being in the world as it relates to their lived experience, it is important to create a therapeutic environment where they can openly talk about and make sense of their experience.

Carefully explaining to the person with spinal cord injury how they may feel as they begin moving their changed bodies during activity and mobility, and listening to what they have to say about how they are experiencing this movement is essential in creating an understanding between the patient and the therapist of the changed body. Effective intervention can only occur when there is open communication between the patient and the therapist. However, because the patient has no history of living with spinal cord injury, it becomes the responsibility of the therapist to initiate this communication and create a safe and trusting therapeutic environment.

Perhaps most devastating is that the change in embodied experience after spinal cord injury often results in a sense of hopelessness. It becomes paramount to expose the patient with spinal cord injury not just to a safe environment through which they can explore their capabilities, but also to seeing that people live full lives after spinal cord injury. This lesson can best occur through increased exposure to mentors who have spinal cord injuries and are living full, happy and useful lives. The exposure should occur while undergoing rehabilitation and after being discharged into the community. Seeing that spinal cord injury and meaningful life can go together promotes the awareness that life goes on.

A traumatic injury that is life altering, like a spinal cord injury, results in a temporal disruption. With no history of disability, many patients cannot conceive of a desirable future. The three participants experienced a sense of depression and suffering as they tried to establish an identity with spinal cord injury. Hope became an essential component in their recovery, experienced through joy and new love. Conceiving of a future was crucial for recovery. Since our experiences and meanings are grounded in our everyday involvement in the world, it becomes essential in therapy to create an environment where patients can envision a new future. In order to build greater meaning from experience patients need to know what is possible in the future. This cannot be achieved if the focus is on the body as it is today. Rather, the focus needs to be on what effect today's actions, with the current body, can have on the future. This future-oriented focus can be used to not only explain why activities are being performed, but also to provide an explanation of progress that is understandable to patients.

Patients often cannot see progress as they lack the understanding of even minor changes in progress due to a lack of knowledge over how they should progress. Stuck in the knowledge of who they were, with no ability to conceive of who they will become, it is hard for patients to see today's actions as improvement or progress. Even the smallest of actions and movements need to be pointed out so that patients can interpret their abilities and transform from being an individual who cannot to a person who can (Papadimitriou, 2008). Therapists cannot create a new temporal identity for patients. Patients must do this themselves. However, they need guidance and support throughout the recovery process to do so. Through narrative interaction, the side-by-side relationship can facilitate the development of a new identity by explaining the present actions as a means to a future possibility.

The three participants in this study identified instances where they did not understand what was said to them. They did not speak the language of the new world they found themselves in. They did not recall their therapists ever asking if they understood what was being said to them. Using the language of their past and incorporating it with the present can assist in understanding how specific therapeutic interventions can lead to improved function. This is how therapists can fight along side their patients. For example, telling a patient that the actions they are performing today they could not complete yesterday, giving them a sense of progression no matter how small.

One participant verbalized that she never felt that her therapists engaged her in the evaluation process for her wheelchair. The wheelchair is a necessity for having the opportunity to engage with others and to initiate movement of the body in the world. Therefore, communication becomes essential in the process of evaluation for and delivery of this very necessary equipment. Another participant also experienced initially utilizing a wheelchair that was demoralizing and that fit him poorly. The third participant however thought his first wheelchair looked cool, though he was not actively involved with the selection of this wheelchair as his therapy team provided it to him. It is significant that all three participants of this study did not feel that they were actively involved in the initial evaluation for equipment, or that the equipment ever fit them. It further supports the need for creating an open narrative with the patient with spinal cord injury and developing goals side by side with them. People with spinal cord injuries are not objects. On the contrary, they are human beings, all different in their own way. As such, the wheelchair cannot be one size fits all, taking into consideration the needs and wants of the person using the wheelchair. Working together to achieve this goal is a very important component of the therapeutic relationship.

References

1. Davidson, J. (2000). A phenomenology of fear: Merleau-ponty and agoraphobic life-worlds. *Sociology of Health and Illness*, 22(5), 95-660. doi:10.1111/1467-9566.00224.
2. Finlay, L. (2006) A bodies disclosure in phenomenological research. *Qualitative Research in Psychology*, 3(1), 19 – 30. doi:10.1191/1478088706qp051oa.
3. Gallagher, S. (2000). Phenomenological and experimental research on embodied experience. Paris, France: Vortrag Bei CREA.
4. Groenewald, T. (2004). A phenomenological research design illustrated. *International Journal of Qualitative Methods*, 3(1), 1-26.
5. Merleau-Ponty, M. (2002). *Phenomenology of perception*. New York, NY: Routledge Classics.
6. Moola, F. J., & Norman, M. E. (2012). Transcending 'Hoop Dreams': Toward a consideration of corporeality, crossroads and intersections, and discursive possibilities in disability and theory. *Qualitative Research in Sport, Exercise and Health*, 4(2), 284-295. doi:10.1080/2159676X.2012.685103
7. Moustakas, C. E. (1994). *Phenomenological research methods*. Thousand Oaks, CA: Sage.
8. Murphy, R. (1990). *The silent body*. New York, NY: W.W. Norton.
9. Papadimitriou, C. (2008). 'It was hard but you did it': The co-production of 'work' in a clinical setting among spinal cord injured adults and their physical therapists. *Disability and Rehabilitation*, 30(5), 365-374. doi:10.1080/09638280701336306
10. Pettersson, I., Appelrosi, P., & Ahlstrom, G. (2007). Lifeworld perspectives utilizing assistive devices: Individuals, lived experience following a stroke. *Canadian Journal of Occupational Therapy*, 74(1), 15-26. doi:10.2182/cjot.06.05.

PS1.4: Clinical Training in Seating and Mobility for Entry –level Physical Therapy Students

Penny J. Powers, PT, MS, ATP
Renee Brown, PT, PhD

Introduction

As the number of individuals with disabilities requiring assistance with mobility increases, there is a greater need for Physical Therapists (PTs) to be trained in Seating and Mobility. In addition, suppliers of seating and mobility devices have expressed frustration with the inability to access adequately trained professionals (PTs and Occupational therapists (OTs)) who have knowledge and skill in seating and mobility. This lack of access to trained individuals limits patients' ability to access quality care as they may be limited to media or web based information which may not accurately and fully address their individualized needs. Education in seating and mobility in entry-level physical therapy programs is variable and most students have limited opportunity in their clinical affiliations to develop the skills for seating and mobility as few seating and mobility clinics offer full time clinical experiences for entry-level students. Students may have intermittent exposure in some rehabilitation center, pediatric centers or skilled nursing facilities, however this intermittent practice does not allow for adequate development of skills across the full spectrum of seating and mobility. This means that few entry-level students have adequate training and practice to address seating and mobility needs of their clients, decreasing patient outcomes. The Clinician's Task Force, which works to address CMS coverage policies for wheeled mobility, and industry leaders are collaborating with the APTA –Neurology Section to develop entry-level expectations for seating and mobility. To address this, we developed both full- time and part-time integrated clinical experiences in seating and mobility which provide students with increased opportunity to develop the knowledge and skills in seating and mobility. These experiences provide the opportunity for students to develop skills that are applicable across patient populations such as communication, problem solving, critical thinking, transfers, ROM, and documentation among others, as well as working as part of an inter-professional team to maximize patient outcomes.

Methods

In collaboration between Vanderbilt Adult Seating and Mobility clinic and Belmont University School of Physical Therapy, affiliation objectives and learning experiences were developed and designed to provide the breadth and depth of training needed in seating and mobility. The didactic preparation in the entry-level program was reviewed and learning experiences including learning modules and on-site experiences were developed to further augment the

information that the student had already been presented in the entry-level physical therapy curriculum, seating and mobility is woven throughout the curriculum and includes: early experiences with wheelchair mobility and determining accessibility of campus and community, seating and mobility evaluation and assessment of advantages and disadvantages of component parts for manual seating and mobility, and then exposure to high tech seating and mobility with assistive technology and environmental control. Building on this foundation, additional learning modules and experiences were developed for the clinical affiliation to cover the entire lifespan as well as the breadth of complexity.

Participants

Both full time and part-time integrated clinical experiences were developed. Students were selected to participate in this specialty clinical affiliation based on their interest in this setting. To date, 3 entry-level doctor of physical therapy students have completed full-time, 8-week clinical affiliations in seating and mobility and one student has completed a part-time 1-day per week integrated clinical affiliation with an additional one in progress. Appendix A provides a list of activities that the students participated in during their clinic experiences. The student's performance was evaluated using the Clinical Performance Instrument (CPI) for full time clinical experience and a program specific assessment for the integrated clinical experiences. In addition, they completed clinical experience evaluations and some provided journal reflections. Follow up survey was conducted to determine the impact on their clinical practice post-graduation

Results

All the students successfully complete their clinical affiliations, meeting the established passing criteria for that experience. The diversity of case mix reported by all the full time students covered the full spectrum (Musculoskeletal, Neuromuscular, Cardiopulmonary, Integumentary and other: GI, GU, Renal, Metabolic, Endocrine). In addition, the experiences covered the entire lifespan. All the full time students rated the experience as "Excellent clinical learning experience", "Time well spent and would recommend this clinical education site to another student." The part-time student indicated "I believe that I learned valuable skills while in seating and mobility." "The skills I learned here will carry over to any setting that I am in for the future." Sample of the reflection from the students included: "Starting from day one I have been rocked by the severity of disability that has been placed in specialized wheelchairs and the care and dedication to detail that goes into each one of those chairs"; "The sheer amount of evaluations on a daily basis allowed to get ample practice with evaluation skills and subjective/history taking skills. Due to the variety of patients I was able to practice a wide variety of evaluation skills from simple muscle/ROM testing to more detailed vision or coordination skills."; "...forcing me to step out of the early skills and really begin to develop my thinking, problem solving and skills."

Conclusion

Specialty seating and mobility clinic can provide entry-level clinical experiences that offer the students the opportunity to develop their entry-level skills while also providing focused training in a specialty area of practice. The learning experiences can be tailored to enable the student to have the breadth and depth of experience to provide both reinforcement of basic skills that are applicable in a wide range of settings as well as advanced specialty skills. The development and implementation of clinical experiences such as these can help address the identified need for skilled clinicians in the area of seating and mobility and encourage individuals to pursue further training in this practice area.

References

1. Deusinger S, Crowner, B, Burlis, T, Stith, J. Meeting Contemporary Expectations for Physical Therapists: Imperatives, Challenges, and Proposed Solutions for Professional Education. *Journal of Physical Therapy Education*, 2014; 28(1), 56 -61.
2. Recker-Huges, C, Wetherbee, E, Buccieri, K, Fitzpatrick, Timmerberg, J, Stoffi, A. (2014). Essential Characteristics of Quality Clinical Education Experiences: standards to Facilitate Student Learning. *Journal of Physical Therapy Education*, 28,(1):48-55.

Appendix A

During the affiliation, the students engaged in the following activities:

- Complete Physical Therapy evaluations
- Accurate measurement for seating and mobility devices
- Identification of needs and challenges for individual patients
- Problems solving regarding seating and mobility options
- Seating and mobility prescription
- Collaboration with a variety of suppliers
- Evaluation and fitting of seating and mobility devices
- Instruction to patients regarding positioning, use, and care for their new seating and mobility device.
- Programming of power devices
- Administration of the FEW (Functioning Every day in a Wheelchair)
- Pressure mapping
- Writing insurance justifications
- Writing appeal letters

Additional clinical experiences:

- Inter-professional Amyotrophic Lateral Sclerosis clinic
- Inter-professional Muscular Dystrophy clinic
- Pediatric Seating and Mobility clinic
- Cloverbottom Developmental Center

Additional experiences outside of the clinic:

- Tour and education at the Permobil NA Headquarters
- Supplier workshops for fabrication of seating and mobility devices
- Travel with supplier for evaluations and build-outs
- Home visit for fitting, delivery and home assessments

IC09: Understanding Pressure Injuries for Effective Prevention

Amit Gefen, PhD

Joyce Black, CWCN, FAAN

Cees Oomens

David M Brienza, PhD

Dan Bader

Background

Understanding the etiology of a pressure injury (PI) is pivotal to prevention (Black et al. 2015). We provide a 360-degree analysis with an assembly of the world's thought-leaders, including researchers, clinicians, and bioengineers – all of whom approach PI prevention in seated clients from their areas of expertise. Central to this discussion are the findings of the world's first and largest randomized clinical trial (RCT) of wheelchair cushions, where it has been discovered how air-cell-based cushions can significantly reduce the incidence of PIs (Brienza et al. 2010). Alternately, we will look at the biomechanical aspects of soft tissue protection and the importance of immersion and envelopment through adequate adjustability and adaptability of the cushion (Gefen 2014). Specific topics address the convergence of ten years of PI prevention research: Why different PI types occur, covering deep tissue injury (DTI) and the distinct contributions of direct deformation versus ischemic damage. A clinician's look at the etiology and presentation of DTIs (covering definitions, timelines and clinical appearance). The RCT of cushions (efficacy of various cushions in PI prevention and a look at how laboratory-derived performance measures relate to clinical outcomes). What makes a cushion effective for PI prevention (presenting the risks of seating, the utilization of the latest bioengineering tools e.g. imaging of human anatomy through seated MRI coupled with finite element modeling and cell culture research to analyze these risks). The research is translated into practical considerations when prescribing a cushion.

Methods

The RCT of wheelchair cushions was conducted in twelve nursing homes, and included 232 participants (Brienza et al. 2010). All participants were provided with a fitted wheelchair and randomized into tissue/skin protection or segmented foam cushion groups. The tissue/skin protection group received air-cell-based cushions, viscous fluid and foam, or gel and foam cushions. The incidence of PIs over half a year for wounds near the ischial tuberosities has been measured. Secondary analysis was performed on combined ischial tuberosity injuries and injuries over the sacrum and coccyx (sacral PIs). In a complementary, bioengineering work, sets of finite element model variants which were developed based

on seated MRI scans was used to determine the state of mechanical deformations and stresses in muscle, fat, and skin tissues under the ischial tuberosities during sitting (Levy et al. 2014a,b, Shoham et al. 2015). Tissue deformation and stress analyses were conducted in different anatomies, incorporating pathoanatomical and pathophysiological changes associated with chronic sitting, including for example bone shape adaptation, muscle atrophy, spasms, obesity, diabetic tissue conditions and scars in superficial as well as in deep tissues.

Results

The combined volume of bioengineering work published over the last ten years by our groups indicates that it is the sustained exposure to tissue deformations which is primarily damaging cells and tissues (Gawlitta et al. 2007, Gefen et al. 2008a,b, Loerakker et al. 2011, Oomens et al. 2010, Stekelenburg et al. 2008). Direct deformation damage occurs much faster (in an order of several to tens of minutes) than purely ischemic damage (which requires several hours to develop). Hence, any type of support surfaces and devices for PI prevention, cushions included, should minimize the sustained exposure to internal tissue deformations and loads, not (just) to interface (skin) pressures. Data from the aforementioned RCT (Brienza et al. 2010) revealed that tissue/skin protection cushions used with fitted wheelchairs, particularly air-cell-based cushions, lower PI incidence for elderly nursing home residents and should be used to help prevent PIs across different facilities. The computer modeling data further indicated that this clinical outcome is achieved by adequate immersion and envelopment of the body in the cushion, which provides more 'safe sitting time' to users. In addition to that, the modeling also pointed to adjustability of the tissue/skin protection cushions as being a critical feature that is essential for prevention of PIs. Adjustability is the ability of the cushion to allow daily function and also accommodate patho-physiological changes that occur over time, such as disuse-related changes (bone and muscle atrophy, changes in muscle/fat mass ratio, weight gain etc.) (Gefen 2014). The key to safe sitting in fragile populations is therefore a tissue/skin protection cushion that simultaneously facilitates immersion, envelopment, and adjustability.

Discussion

Sitting acquired PIs are often deep tissue injuries (DTIs), which can be difficult to diagnose because many other skin and wound problems can appear as purple skin or rapidly appearing eschar. However, accurate diagnosis of DTIs is critical and can be life-saving. The proper diagnosis of DTI begins with a thorough history to account for times of exposure to weight-bearing, such as 'time down' at the scene or time during which the patient was immobile and could not respond to discomfort and pain (Black et al. 2015). In order to avoid DTIs, state-of-the-art clinical RCT-based data and bioengineering work all point to certain critical design features that need to be present in a good cushion for PI prevention: (i) Envelopment which is the cushion's ability to "wrap around" the buttocks and produce more side loading that disperse bodyweight loads when the body is immersed in the cushion. (ii) Adjustability which is the cushion's ability

to allow daily function and also accommodate patho-physiological changes that occur over time. With those two primary characteristics, the pattern of use of the cushion and the environment in which it is typically being used need to be considered as well, and hence, two additional key features are added: (iii) Adaptability which is the cushion's ability to also adapt to changes in the user's sitting position throughout the day (that is influenced by numerous factors, including e.g. their shoes and wardrobe). (iv) Durability which is the cushion's ability to maintain its structure, properties, function and performance over time when subjected to prolonged use and (often hostile) environmental conditions.

Conclusions

The science of PI prevention has advanced considerably over the last two decades. Now, with the better understanding of the etiology of PIs and DTIs, and given the availability of powerful imaging modalities and computer modeling that facilitate examination of the mechanical and biological conditions in deep tissues, the road for scientifically evaluating the efficacy of PI prevention equipment is paved. In this presentation we link between basic science bioengineering findings, clinical findings from RCT of cushions, and clinical experience and expertise, which altogether shape the key factors that should be considered in any cushion product selection or design process: minimize exposure to sustained tissue deformations as much as possible, by maximizing envelopment while facilitating adjustability, adaptability, and durability. With that being said, there are still considerable gaps between the state of science, public healthcare policy and current practice in cushion prescription, evaluation and purchasing decision-making, which need to be narrowed through multi-disciplinary collaborations and joint work, as conducted here.

References

1. Black, Joyce M., Brindle, C. and Honaker, J. (2016) "Differential Diagnosis of Suspected Deep Tissue Injury." *International Wound Journal*, 14(4): 531-539.
2. Brienza, D. K., Sheryl; Karg, Patricia; Allegretti, Ana; Olson, Marian; Schmeler, Mark; Zanca, Jeanne; Geyer, Mary Jo; Kusturiss, Marybeth; Holm, Margo (2010). "A Randomized Clinical Trial on Preventing Pressure Ulcers with Wheelchair Seat Cushions" *Journal of the American Geriatrics Society* 58(12):2308-2314.
3. Gawlitta D, Li W, Oomens CW, et al. (2007). "The Relative Contributions of Compression and Hypoxia to Development of Muscle Tissue Damage: an in Vitro Study" *Ann Biomed Eng.* 35(2):273-284.
4. Gefen A, Cornelissen LH, Gawlitta D, et al. (2008a) The Free Diffusion of Macromolecules in Tissue-Engineered Skeletal Muscle Subjected to Large Compression Strains" *J Biomech* 41(4):845-853
5. Gefen A, van Nierop B, Bader DL, Oomens CW (2008b). "Strain-time Cell-Death Threshold for Skeletal Muscle in a Tissue-Engineered Model System for Deep Tissue Injury" *J Biomech.* 41(9):2003-2012.
6. Gefen, A. (2014). "Tissue Changes in Patients Following Spinal Cord Injury and Implications for Wheelchair Cushions and Tissue Loading: A Literature Review" *Ostomy Wound Management*. Feb: 34-45.
7. Levy A, Kopplin K, Gefen A. (2014a). "An Air-cell-based Cushion for Pressure Ulcer Protection Remarkably Reduces Tissue Stresses in the Seated Buttocks with Respect to Foams: Finite Element Studies" *J Tissue Viability* 23(1):13-23.
8. Levy A, Kopplin K, Gefen A. 2014b). "Computer Simulations of Efficacy of Air-cell-based Cushions in Protecting Against Reoccurrence of Pressure Ulcers" *J Rehabil Res Dev.* 51(8):1297-1319.
9. Loerakker, S Manders, E Strijkers, GJ, Nicolay, K ,Baaijens, F. P. T., Bader, DL, Oomens, CWJ (2011). "The Effects of Deformation, Ischemia, and Reperfusion on the Development of Muscle Damage During Prolonged Loading" *Journal of Applied Physiology* 111 (4):1168-1177.
10. Oomens CW, Loerakker S, Bader DL. (2010). "The Importance of Internal Strain as Opposed to Interface Pressure in the Prevention of Pressure Related Deep Tissue Injury" *J Tissue Viability* 19(2):35-42.
11. Shoham N, Levy A, Kopplin K, Gefen A. (2015) Contoured foam cushions cannot provide long-term protection against pressure ulcers for individuals with a spinal cord injury" *Adv Skin Wound Care.* 28(7):303-316.
12. Stekelenburg A, Gawlitta D, Bader DL, Oomens CW. (2008) "Deep Tissue Injury: How Deep is our Understanding?" *Arch Phys Med Rehabil.* 89(7):1410-1413.

IC10: What's the Latest: Medicare Documentation & Coverage Requirements

Claudia Amortegui, MBA

Background:

The past several years brought changes to the Medicare funding requirements of all durable medical equipment (DME) including complex rehab technology (CRT). 2016 was a tumultuous year for such changes. There were cuts in reimbursement, updated policies, and changes in claim submission. Not only did these changes effect Medicare itself, but much of this also trickled down to all other funding sources.

The industry is now at the verge of more critical changes that are scheduled to take place at the beginning of 2017. There is a bit of hope that CRT will be saved from some of these changes. The industry needs to look at where it stands today when it comes to proper coverage and reimbursement in order to succeed as a provider and to prescribe appropriate equipment which would be funded by Medicare.

Discussion:

It has seemed as if CMS is constantly making changes in the industry. For many years, this was not necessarily a true statement. It appears there was bigger issue with provider staff feeling as if the changes were endless, however it was more the length of time it took to truly understand what Medicare now required and expected.

2016 did bring several changes in Medicare funding and it is hoped that the 2017 changes will not include CRT.

Significant cuts in reimbursement were made starting July 2016 due to the Competitive Bid program. Although CRT was originally carved out of Competitive Bidding, the allowables have now been applied to all replacement parts with the exception of Group 3 power wheelchairs. This means that the lower payments now apply to those parts on CRT manual wheelchairs and Group 2 power wheelchairs with powered seating. Also, the instructions and modifier that allow for higher payment of parts on Group 3 power wheelchairs is set to be eliminated effective January 1, 2017.

Effective July 1st, 2016, Medicare allowed a lump sum payment of replacement parts that fall under the capped rental category. This included any rentals of replacement parts that started prior to October 1st. Unfortunately, the initial instructions on how to bill these items was incorrect. The methodology for modifier usage was updated after the changes took effect.

Due to these issues, the CRT industry has been fighting to stop the year-end cuts to CRT options/accessories. This is a bipartisan issue that has gained much support. The hope is that House and Senate bills are attached to legislation that will be passed in time to stop the changes. Sadly, this is not the only issue facing the industry. Coding and policy have also been problems; more so due to Medicare wanting to fit all mobility into a "pretty little box."

One example of codes issues, started in February 2016 when an article was published by the Medicare PDAC contractor (responsible for coding). The article stated that the code E0995 defined as Calf Rest/Pad was to be used when billing for a Footbox. The industry quickly reacted and the article was rescinded within four days of the original publication. It was believed by most, if not all, that Medicare had changed their position on the coding instructions. It has been learned, that this is not the case and that they still believe the Calf Rest/Pad code is correct for use when billing a footbox. The issue is the allowable; it is less than \$25.00 on most wheelchairs. On Group 3 CRT power wheelchairs, the allowable is less than \$29.00. This has caused many to stop providing footboxes to their Medicare-only clients.

With these issues, plus many more, the industry has been in a long fight for CRT to have its own separate benefit category similar to orthotics and prosthetics. This would eliminate the current issues with the Competitive Bid Program as it relates to CRT. This should also allow for some new and better coding of CRT options and accessories. At this point, Medicare tends to group "similar" products, at least what they deem as "similar." Unfortunately, this has caused issues with items that can be basic or complex such as headrests and positioning belts.

Conclusion:

Although the fitting and selection of the appropriate mobility equipment is critical, having the equipment funded is just as important, in order to allow the end-users to obtain such equipment. Funding for CRT continues to change, therefore understanding the current requirements is vital. Much of the process may be similar but even the smallest adjustments to the requirements must be understood and applied. This will allow the end-user to receive the best service both clinically and by their providers.

References:

1. DME MAC Jurisdiction C Supplier Manual - Chapter 5 (Fee Schedule Categories), Section 9 (Repairs, Maintenance, and Replacement), Summer 2016
2. Medicare MAC website - CGS: Complex Rehab FAQs - CGS, 6/23/16; Repair Labor Billing & Payment Policy, 2/26/09, Billing Reminders for HCPC Code K0739, 5/22/14
3. CMS Local Coverage Determinations (LCDs) and Articles: Manual Wheelchairs (L11443), 7/1/16; Power Mobility Devices (L23613), 7/1/16; Wheelchair Options/ Accessories, Wheelchair Seating (L15887), 7/1/16

IC11: Optimizing the Ride: How Manual Wheelchair Configuration Enhances Function

Jennith Bernstein, PT, DPT, PT
Devon Doebele, PTA

The extensive amount of choice regarding manual wheelchair configuration and optimization could leave potential for misunderstanding and misuse of each application. Throughout this course, we plan to review classic and new literature to identify the benefits and potential drawbacks of chair configuration, manual wheelchair measurements and geometry, as well as the influence of accessories to the overall function and utilization of a manual wheelchair as an extension of the rider. Considerations on chair accessories and their influence on optimal chair set up and configuration. How to choose wisely and not make compromises. In addition, discussion regarding teaching methods and objective measures to ensure satisfaction and performance of each individuals skill when utilizing an optimized manual wheelchair.

How do components influencing optimally configured chair influence functional outcomes? Does it matter if a chair has suspension? What does a pneumatic tire really do? How does it impact the users/riders maneuverability within their environment, and the effects on propulsion and energy expenditure, efficiency and ultimately long term effects on influencing RSI incidence?

Once you have identified the need for an optimally configured chair, how do you progress and reevaluate how to continue the reconfiguration as a person's functional capacity improves. When do you make an adjustment to the COG? How does it impact the rider's ability to maximize the chair set up to meet their skill advancement? How do we apply this to a clinical setting to quickly and efficiently determine optimal COG based on wheelchair skills? Discuss solutions on how to avoid prescribing an adjustable chair but leaving it a sub-optimal set up, which does not match the user's abilities as they advance. How do we determine why we need to adjust a chair, what tools are available for use? How do we overcome resistance to change? How do we communicate to someone what they don't know they don't know?

Presentation to include a brief review of outcome measures that can be utilized to support and evaluate effectiveness of adjustment that you took the time to make. The ultimate take away is how your choices and measurements and equipment section are influencing success of MRALS, life satisfaction and overall participation and independence for the rider.

Demonstration regarding specific wheelchair adjustments such as wheel access and footplate height and how they influence balance, stability, and function.

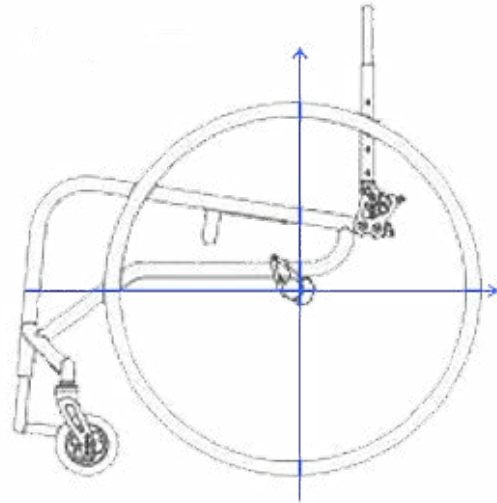

References

1. Caspall, J. J., Seligsohn, E., Dao, P. V., & Sprigle, S. (2013). Changes in inertia and effect on turning effort across different wheelchair configurations. *Journal of Rehabilitation Research and Development J Rehabil Res Dev*, 50(10), 1353-1362. doi:10.1682/jrrd.2012.12.0219
2. DiGiovine, C., Rosen, L., Berner, T., Betz, K., Roesler, T., & Schmeler, M. (2012). RESNA Position on the Application of Ultralight Manual Wheelchairs, [position paper]. Rehabilitation Engineering & Assistive Technology Society of North America. Retrieved April 6, 2016 from <https://www.resna.org/sites/default/files/legacy/resources/position-papers/UltraLightweightManualWheelchairs.pdf>
3. Groot, S., Post, M.W., Bongers-Janssen, H.M., Bloeman-Vrencken, J.H., van der Woude, L.V. (2011). Is manual wheelchair satisfaction related to active lifestyle and participation in people with spinal cord injury? *Spinal Cord*, 49, 560-565.
4. Kwarcia, A.M., Yarossi, M., Ramanujam, A., Dyson-Hudson, T. A., & Sisto, S.A. (2009) Evaluation of wheelchair tire rolling resistance using dynamometer based coast-down tests. *Journal of Rehabilitation Research & Development*. 46 (7). 931-938.
5. Sakakibara, B.M., Miller, W.C., Eng, J.J., Backman, C.L., & Routhier, F. (2014). Influences of Wheelchair-Related Efficacy on Life-Space Mobility in Adults Who Use a Wheelchair and Live in the Community. *Physical Therapy*, 94(11), 1604-1613.
6. Worobey, L. A., Kirby, R. L., Heinemann, A. W., Krobot, E. A., Dyson-Hudson, T. A., Cowan, R. E., . . . Boninger, M. L. (2016). Effectiveness of Group Wheelchair Skills Training for People With Spinal Cord Injury: A Randomized Controlled Trial. *Archives of Physical Medicine and Rehabilitation*. doi:10.1016/j.apmr.2016.04.006

IC12: Powered Wheelchair Provision: Current practice and opportunities for success

Emma M. Smith, MScOT, ATP/SMS

Lisa K. Kenyon, PT, DPT, PhD, PCS

Debra Field, OT, PhD

William C. Miller, PhD, FCAOT

Background

Powered wheelchairs provide important opportunities for participation in daily life for individuals with mobility limitations (Auger et al., 2008; Brandt, Iwarsson, & Stähle, 2004; Mortenson, Hammell, Luts, Soles, & Miller, 2015). For an individual to obtain a powered wheelchair, they are typically required to undergo a process of assessment and training to ensure competence and safety with use of the device (W B Mortenson et al., 2006; W. W. B. Mortenson et al., 2005). Therefore, assessment and training of wheelchair skills are recognized as important steps in the powered wheelchair provision process. (RESNA, 2011) Unfortunately, there is minimal research regarding the assessment and training provided by clinicians.

An understanding of current practice helps to guide research in the area by establishing standard practices for comparison and providing an opportunity to identify gaps in the assessment and training of powered wheelchair users which can be addressed clinically and in research. Therefore, we conducted a survey of clinicians in the field of powered wheelchair to identify current practices in powered wheelchair assessment and training. The objective of this workshop is to examine current practices in powered wheelchair skills assessment and training in a variety of practice settings and populations in Canada and the United States of America. We will use an understanding of current practices as a Launchpad for a discussion of those practices which are or are not supported by research evidence, and identify areas for future learning.

Methods

We developed an online survey utilizing themes generated from a series of qualitative interviews recently completed by the research team on powered wheelchair provision (in preparation for publication), and the clinical experience of the researchers. The survey consisted of open and closed questions. Closed questions typically used ordinal response which were tailored to address the specific content of the question (i.e. frequency, agreement). The survey was administered to individuals in Canada and the United States of America who engage in powered mobility provision including occupational therapists, physical therapists,

rehabilitation assistants, assistive technology professionals, seating and mobility specialists, and medical equipment dealers/vendors. Results from the survey were analyzed using descriptive statistics with thematic qualitative analyses for answers from open ended questions. Based on the results of this survey, we identified challenges and strengths within current practice. This was followed by a literature review to explore any available research evidence associated with current practices, and to identify gaps in evidence supporting practice.

Findings and Discussion

The results from the survey raised a number of questions for further exploration related to powered mobility assessment and training. In this workshop, we aim to address these questions and explore the current state of the research evidence which does or does not support current practice. These discussions will be broadly grouped into pre-assessment, in-chair driving assessment, and powered wheelchair skills training.

More than half of clinicians surveyed identified pre-requisite skills or capacities which must be met prior to proceeding with an in-chair driving assessment. These pre-requisites most often include cognition, motor skills, vision, attention, and visual motor skills. The decision to provide powered mobility to a client, or to engage in training was often influenced by the cognitive status of the client. This is typically assessed informally, or, less frequently, through the use of a standardized cognition tool. Although there is some limited evidence to suggest there is a relationship between cognition and frequency of wheelchair use (Cullen, O'Neill, & Evans, 2008; Massengale, Folden, McConnell, Stratton, & Whitehead, 2005), we were unable to identify research which has systematically addressed the influence of cognition on powered mobility driving skills. This area has been addressed more systematically within the pediatric literature, with a focus on developing cognition and powered mobility driving (Nilsson & Eklund, 2006). Given the limited evidence in this area, this represents an area of focus for powered mobility research. In particular, there is an opportunity to better understand those skills which are required for safe driving and should be addressed prior to engaging in in-chair assessment and training, and those which should be considered for review. It is also important to establish the relationship between standardized outcome measures used to assess vision, visual motor skills, and cognition, and the results of measures to assess driving proficiency and safety.

In general, respondents infrequently used powered wheelchair skills assessments which are supported by research evidence in their practice (i.e. Wheelchair Skills Test, Power Mobility Indoor Driving Assessment). Of those assessments which are supported by published research evidence, each was used "rarely" or "never" a majority of the time. While there are powered mobility driving assessments available to clinicians with support for reliability in the literature, including the Wheelchair Skills Test, the Power Mobility Indoor Driving Assessment, and the Power Mobility Community Driving Assessment, these were not used by a majority of respondents. (Dawson, Chan, Kaiserman, & E, 1994; Kirby et al., 2016) Although respondents' reasons

for not using assessment tools supported by the research evidence were not explored, there appears to be an opportunity for knowledge translation of these assessments, or suggests that the assessments do not meet a clinical need.

In addition, the majority of respondents were not currently using a specific wheelchair skills training program in their practice, likely due to the fact there are limited options available within the published literature. Research evidence specific to training is limited, however there are notable exceptions within the pediatric literature, where additional focus has been placed on developmental learning associated with powered mobility. In general, training practices appear to vary depending on the client and their unique needs; this will be further explored in the workshop.

Conclusions

Clinicians who responded to the survey largely use tools which are not supported by the research evidence. This is likely related to minimal evidence available in the field of powered mobility and training. Ultimately, an improved understanding of this area will lead to improved knowledge translation of current evidence, and opportunities to enhance clinical practice in the field, contributing to the establishment of best practices.

References

1. Auger, C., Demers, L., G elinas, I., Jutai, J., Fuhrer, M. J., & DeRuyter, F. (2008). Powered mobility for middle-aged and older adults: systematic review of outcomes and appraisal of published evidence. *American Journal of Physical Medicine & Rehabilitation (AM J PHYS MED REHABIL)*, 87(8), 666–680. Retrieved from <http://search.ebscohost.com/login.aspx?direct=true&db=c8h&AN=2009986574&site=ehost-live>
2. Brandt,  ., Iwarsson, S., & St ahle, A. (2004). Older people's use of powered wheelchairs for activity and participation. *Journal of Rehabilitation Medicine*, 36(2), 70–77. <http://doi.org/10.1080/16501970310017432>
3. Cullen, B., O'Neill, B., & Evans, J. J. (2008). Neuropsychological predictors of powered wheelchair use: a prospective follow-up study. *Clinical Rehabilitation*, 22(9), 836–46. <http://doi.org/10.1177/0269215508091873>
4. Dawson, D., Chan, R., Kaiserman, E., & E, D. D. ; C. R. ; K. (1994). Development of the Power-Mobility Indoor Driving Assessment for Residents of Long-Term Care Facilities: A Preliminary Report. *Canadian Journal of Occupational Therapy*, 61(5), 269–276. <http://doi.org/10.1177/000841749406100507>
5. Kirby, R. L., Smith, C., Parker, K., McAllister, M., Boyce, J., Rushton, P. W., ... Brandt,  . (2016). *Wheelchair Skills Program Manual*. Retrieved from www.wheelchairskillsprogram.ca/eng/manual.php
6. Massengale, S., Folden, D., McConnell, P., Stratton, L., & Whitehead, V. (2005). Effect of visual perception, visual function, cognition, and personality on power wheelchair use in adults. *Assistive Technology : The Official Journal of RESNA*, 17(2), 108–21. <http://doi.org/10.1080/10400435.2005.10132101>
7. Mortenson, W. B., Hammell, K. W., Luts, A., Soles, C., & Miller, W. C. (2015). The power of powered wheelchairs: Mobility choices of community-dwelling older adults. *Scandinavian Journal of Occupational therapy*, 22(5), 394–401.
8. Mortenson, W. B., Miller, W. C., Boily, J., Steele, B., Crawford, E. M., & Desharnais, G. (2006). Overarching principles and salient findings for inclusion in guidelines for power mobility use within residential care facilities. *Journal of Rehabilitation Research & Development*, 43(2), 199–208. Retrieved from <http://search.ebscohost.com/login.aspx?direct=true&db=c8h&AN=2009243442&site=ehost-live>
9. Mortenson, W. W. B., Miller, W. W. C., Boily, J., Steele, B., Odell, L., Crawford, E. M., & Desharnais, G. (2005). Perceptions of power mobility use and safety within residential facilities. *Canadian Journal of Occupational Therapy*, 72(3), 142–152. <http://doi.org/10.1177/000841740507200302>
10. Nilsson, L., & Eklund, M. (2006). Driving to learn: Powered wheelchair training for those with cognitive disabilities. *International Journal of Therapy and Rehabilitation*, 13(11), 517–527. Retrieved from <http://www.ijtr.co.uk/cgi-bin/go.pl/library/abstract.html?uid=22466>
11. RESNA. (2011). *Wheelchair Service Provision Guide*. Arlington, VA. Retrieved from <http://www.nrrts.org/clinicians/RESNAWheelchairServiceProvisionGuide.pdf>

We (Emma Smith, Lisa Kenyon, Debra Field, and William Miller) do not have any conflicts of interest to disclose. Specifically, none of the authors have an affiliation (financial or otherwise) with an equipment, medical device, or communications organization.

IC13: Posture, the Missing Link in Finite Modeling

Alexander Siefert, PHD

Bart Van der Heyden, PT

In a clinical setting the wheelchair's seat angles, knee angles and back support angles are adjusted according to the needs of the individual. Complications associated with these adjustments are common and include: increased stresses at weight bearing tissues, skin integrity issues, sliding and discomfort.

But what is exactly the effect of these postural interventions on skin integrity, sliding tendency and the wheelchair user's comfort levels and can these effects be predicted?

The Finite Element Method (FEM) is used in many industries to investigate stresses and strains for evaluating design variants of products. Due to the complexity of the human body its representation in computations is very difficult. Nevertheless models of the human body have been developed within the last years to investigate seat designs with respect to crash and comfort requirements.

A 3 dimensional FEM model, which offers the opportunity to compute internal tissue stresses at the buttock area with different postures and seating angles has been recently developed. Because of the vast amount of possible postural adjustment options its effect on tissue loading would be impossible to obtain through clinical trials. Accordingly a whole 3D human body model was combined with a common seat designs to investigate the effect of postural changes. Thereby non-measurable quantities as e.g. internal tissue loads have been used to evaluate the posture, which is another benefit compared to other measurement campaigns.

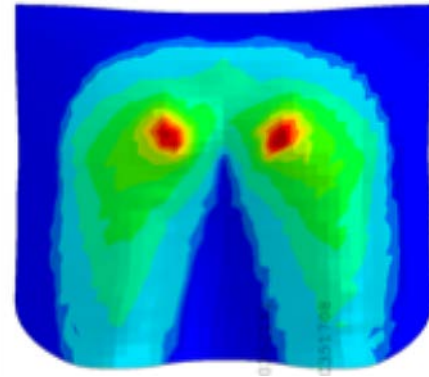

Figure 1: 3D Model setup and result for pressure distribution

This presentation will show first the general capabilities of 3D FEM and its requirements for the application to assess wheelchair designs. Finally the results regarding the influence of the posture and seat angles on tissue loads will be presented.

Learning objectives:

- Understand the use of 3D FEM for evaluation of wheelchair designs
- Understand the validation of 3D FEM for evaluation of wheelchair designs
- List at least 3 effects of common postural adjustments on tissue loads
- Describe at least 3 influences of seat adjustments on tissue loads
- List at least 4 application of how findings from 3D FEM can be applied for wheelchair adjustments.

References:

1. Siefert A, Hofmann-Rösener M, Lachenbruch Ch. Numerical Study of different Types of Supporting Structures regarding the Prevention of Deep Tissue Injuries. Presentation at 17th Annual European Pressure Ulcer Meeting, Stockholm, Sweden, September 2014
2. Siefert A, et al. Detailed FE-Model of the Buttock as a part of a Multi-Scale-Approach for numerical investigations of Deep Tissue Injuries (DTI). Presentation at 15th Annual European Pressure Ulcer Meeting, Cardiff, Wales September 2012
3. Siefert A, Siebert T. Passive and Active Muscle Tissue Approach for Human Body Model CASIMIR. Proceedings of CMBBE 2012, Berlin, Germany, April 2012
4. Loerakker S. The relative contributions of muscle deformation and ischaemia to pressure ulcer development. PHD thesis TU Eindhoven, 2011, ISBN 978-90-386-2550-8
5. Siefert A, Pankoke S, Wölfel, H-P. Virtual optimisation of car passenger seats : Simulation of static and dynamic effects on drivers' seating comfort. International Journal of Industrial Ergonomics, 2008, Volume 38, p. 410-424
6. Oomens CWJ et al.: Finite element Modelling of contracting skeletal muscle. Philosophical Transactions of the Royal Society B (2003), Volume 358, 1453-1460

IC14: Understanding Paediatric Mobility Needs from Parental Perspective

Laura Finney
Sheila McNeill

Background

A vast array of wheelchairs and adaptive strollers are available for young children with mobility needs. Initially, standard commercial products aimed at typically developing children are often adequate. However by the time the child is approximately 18 months old these low cost options no longer meet the requirements of children with disabilities (Antoniuk, Livingstone & Ott, 2012), and specialised equipment is required.

For a wide range of reasons, parents of young children often prefer an adaptive stroller to a paediatric wheelchair (Shahid, 2004). Clinicians are aware that it is not uncommon for families to require multiple conversations about the idea of evaluating for and transitioning to a wheelchair (Kiger, 2015). In a comparative study of Parent and Therapist views of the child's individual seating systems, McDonald (2003) showed that the views of the therapist prescribers differed from those of the parents. Parents focussed on functional and practical concerns such as toileting and transferring, whereas therapists concentrated on postural and technical issues.

Perhaps unsurprisingly, Thomas-Stonell, Oddson, Robertson and Rosenbaum (2010) showed that parents are often more perceptive in noticing the effects of clinical interventions compared to clinicians. Yet in the vast majority of medical models, be they insurance led or government funded, it is a prescribing clinician who leads and often steers discussions on appropriate therapeutic intervention. For these clinicians, understanding their clients' needs can be a real challenge; family, lifestyle, individual preferences and beliefs, should be taken into account to enable therapists to have a more holistic understanding of the child's needs and not miss the 'bigger picture' (Fisher & Harvey, 2015).

Method

This course will draw on the combined expertise of 678 parents who completed two online questionnaires, examining the transition from stroller to wheelchair. An initial survey focussed on practical considerations, including how the transition came about and in what manner they interact with this new equipment during the course of a day. The second survey employed a more holistic approach, recognising that the child resides within a family unit and that the intervention will have an impact on and will be impacted by other family members (Henderson, Skelton and Rosenbaum, 2008). It utilised the International Classification of Functioning, Disability and Health – Children and Youth Version (ICF-CY) to identify environmental factors, such as the parents' view of their child's perception by others, along with personal factors, such as their independence.

Findings & Discussion

The transition from stroller to wheelchair was shown to be predominantly initiated by the child's clinician. The relative importance of the many factors involved in choosing the new wheelchair; comfort, weight, aesthetics, reliability, ease of use, will be explored. When examining the impact of the wheelchair on the family unit, a picture emerges of equipment which has the power to frustrate and delight, often in equal measures. Wheelchairs are tilted and folded frequently throughout the day and the device soon becomes an integral part of general family life. For manufacturing reasons, wheelchairs which tilt are more costly to produce, and specific criteria often exist to limit provision. The eclectic range of benefits cited by parents for requiring tilt, and yet not typically part of the criteria, help explain the dissatisfaction pertaining to this feature. Views varied depending on the outcome measure assessed, the type of chair prescribed and the needs of the individual child and family. Reassuringly the role of the therapist during this transition is overwhelmingly positive, however the same can't be said of either the prescribing system/organisation or the equipment on offer. The open ended responses revealed with alarming regularity, the anger, hurt and frustration parents feel regarding the variety of equipment on offer and the lack of control of their situation.

Conclusion

Wheelchairs are essential equipment for many children with disabilities. Engaging directly with parents has yielded valuable insights which could assist clinicians and mobility manufacturers in their practice, ultimately resulting in clinical and functional benefit to the family and the child.

References

1. Antoniuk E, Livingstone R and Ott B (2012) Mobility Prescription: From Infancy through Adolescence and Beyond. Proceedings of the 28th International Seating Symposium, Vancouver, 41-44.
2. Fisher K and Harvey M (2015) Do we really know our clients? Lessons learned from a client feedback survey. Proceedings of the 31st International Seating Symposium, Pittsburgh, 119.
3. Henderson S, Skelton H and Rosenbaum P (2008) Assistive devices for children with functional impairments: impact on child and caregiver function. *Dev Med Child Neurol*, 50:89-98.
4. Kiger A (2015) Grow, play, learn, explore! – Introduction to pediatric seating and mobility. Proceedings of the 31st International Seating Symposium, Pittsburgh, 77-78.
5. Shahid M. Buggy-to-wheelchair progression for children with cerebral palsy: Parents' and therapists' opinions. *Int J Ther Rehabil* 11(12):560–566.
6. Thomas-Stonell NL, Oddson B, Robertson B, Rosenbaum PL (2010) Development of the FOCUS (Focus on the Outcomes of Communication Under Six), a communication outcome measure for preschool children *Dev Med Child Neurol* 52(1):47-53.
7. World Health Organisation (2007) International Classification of Functioning, Disability & Health – Children and Youth Version Retrieved from http://apps.who.int/iris/bitstream/10665/43737/1/9789241547321_eng.pdf?ua=1

IC15:

**This Presentation
is cancelled**

IC16: Assistive Robotics for Activities of Daily Living

Dan Ding, PhD

Hongwu Wang, PhD

Chengshiu Cheng, PhD

Hyun Ka, PhD,

Rory Cooper, PhD

Background

People who use powered mobility devices including those with high-level spinal cord injury (SCI), amyotrophic lateral sclerosis (ALS), and multiple sclerosis (MS) often have impaired upper extremities¹. Upper extremity impairments can lead to functional limitations in reaching and handling which are critical in completing activities of daily living (ADLs) such as self-care, self-feeding, and meal preparations². A number of surveys have shown that these individuals often considered that regaining arm and hand function would most improve their quality of life³⁻⁵. Despite the advancement in surgical restoration and use of neuroprosthesis through functional electrical stimulation⁶, there is still a gap in providing viable solutions to support upper limb functions among these individuals. Many of these individuals still require assistance from a personal caregiver for essential ADLs involving object handling. However, with the shortage of personal care attendants and caregiver burden, it is challenging to fulfill the rapidly growing needs for caregivers⁷. The inability to perform ADLs independently may also trigger the need for relocation to residential care settings, which could significantly impact the quality of life and self-esteem of these individuals⁸.

Assistive robotic manipulators (ARMs) that aims to assist rather than restore functions offer a unique solution to help these individuals complete some daily tasks involving object handling and manipulation. The ARMs support long-term daily use and do not need to be donned and doffed as wearable devices. They can also accommodate a wide range of diagnoses as long as users can use joystick or switch controls to operate their powered wheelchairs. The training and maintenance requirements are also more reasonable when compared with surgical and neuroprosthesis interventions. ARMs can be mounted on a powered wheelchair, placed on a mobile platform, or installed at a fixed location. There are a number of research prototypes. For example, The EL-E developed at Georgia Tech is an ARM mounted on a mobile platform that aims to help people with motor impairments with object retrieval by pointing to an object with a laser pointer or on a touch screen⁹. The ProVAR developed at the VA Palo Alto is a manipulation assistance system installed at a fixed location, where a robotic arm mounted on an overhead track above a desk was controlled via voice commands to assist people with high-level SCI with vocational tasks in a workplace setting¹⁰. There are also two commercially available ARMs, i.e., MANUS/iARM (Exact

Dynamics, Netherland) and JACO/MICO (Kinova Robotics, Canada). Both ARMs are designed to mount on a powered wheelchair and controlled by a joystick or keypad. In this instructional workshop, we will discuss the existing acquiring process of ARMs and evidence on their effectiveness on providing assistance on ADLs. We will also introduce a custom ARM assessment tool that could potentially aid the prescription and training of ARMs. We will demonstrate a few alternative control interfaces including voice control, touch control, and vision-based control.

Assessment Tools

Both JACO and iARM are light-weight robotic manipulator with a payload around 2kg. They are composed of six inter-linked segments and a two- or three-fingered hand, and typically mounted to the side of a powered wheelchair seat frame allowing it to follow the tilt movement of the seat. They can be operated with the existing wheelchair controllers through a joystick or other alternative controls (e.g., head array and sip and puff). ARMs are relatively new and complex assistive technology that many clinicians are not familiar with. Unlike wheelchairs and prosthetic devices, there is not yet a standardized provision procedure for ARMs or any guidelines to support clinical service delivery of ARMs. Purchases are typically made from out-of-pocket expenses that are not reimbursable by most insurances.

To support a standardized provision process for ARMs, we have developed two versions of the assistive robotic manipulator evaluation tool (ARMET). ARMET v1.0 includes six common objects, i.e., a large-size round button similar to a door opener, a small-size round elevator button, a rectangular-shape rocker light switch, a toggle switch, a door handle, and a radial knob¹¹. It is instrumented with sensors that detect the start and end time of a task and provide accurate task completion time. It also calculates the ISO 9241-9 throughput based on Fitt's Law and trajectory roughness of ARM movements, which provides additional indicators on user performance with ARMs. The throughput combines a task's index of difficulty (ID) with the completion time. The trajectory roughness is calculated as variance related to the straight line from the start to the end point of a task. We have also conducted two focus groups with five potential ARM users, three clinicians, and three researchers¹². All participants agreed that the ARMET would be useful assessment and training tool. All clinicians/researchers expressed that such a tool would be beneficial to clinical service delivery or research. They also stressed the need to have tasks with different levels of difficulty and complexity, and suggested adding additional modules to ARMET v1.0. Based on user feedback, ARMET v2.0 is being designed to be portable, easy to set up, and modular. The modular panels are interchangeable and thus allows for changing the setting of tasks, and adding additional tasks. We have ongoing research to examine the construct and predictive validity of ARMET v2.0.

Control Interfaces of ARMs

The default joystick and keypad control interfaces for ARMs can be difficult for individuals with severe muscle weakness/paralysis or impaired ability to grip. There are also cognitive challenges in operating the ARMs using different modes (i.e., translate, rotation, and grip). We developed two smartphone-based interfaces for JACO, i.e., touch-joystick and touch-keypad that allow users to control the arm with minimal physical exertion and no difficult motion such as grasping or twisting¹³. We compared the touch-joystick and touch-keypad interfaces with the default joystick interface on ARMET v1.0. Both touch interfaces showed significantly higher ISO9241-9 throughput than the default joystick interface, indicating more efficient operation with the touch interfaces.

In addition to manual controls, work has also been conducted on using sensors such as cameras to enhance the perception of ARMs for autonomous operations. The literature mostly described the technical details of the development and was limited in performing user evaluations. Only a handful of studies reported results from user evaluations. Kim et al. evaluated MANUS (Exact Dynamics, Netherland) with 10 individuals with SCI¹⁴. Half of the subjects controlled the arm manually with a joystick to complete pick-and-place tasks where six objects were placed on a two-level shelf (three on each level with generous space in between). The other half controlled the arm autonomously by selecting the object of interest on a touch screen. After a three-week trial, the autonomous and manual modes had comparable task completion times while user effort required for operating the robot in autonomous mode was significantly less than that for the manual mode. Laffont et al. conducted a similar study where 24 control subjects and 20 severely impaired patients used MANUS augmented by a panoramic camera for autonomous operation to pick 6 objects on the shelf or table¹⁵. Subjects with severe impairments spent twice the amount of time needed by the control subjects to complete the task, but reported high satisfaction with the arm. We have developed a 3D vision-based semi-autonomous control for ARMs¹⁶⁻¹⁷. A working prototype was built on JACO equipped with a low-cost short-range 3D depth-sensing camera. A user starts operating the arm using a preferred manual control method. In addition to the default joystick and keypad control, we have also implemented the touch interfaces and voice control for user selection. During the operation, when the camera detects an object within a set range, the arm is automatically stopped, and users are then presented with possible manipulation options (e.g., ignore it, push it, pick it up, and tap it etc.) through auditory feedback. They can select one option by saying a voice command. The system then drives the arm autonomously based on the orientation and proximity of the target object provided by the camera until the given command is completed or the user interrupts it. We have tested the system with 10 able-bodied individuals and 5 power wheelchair users with upper limb impairments. It was found that the semi-autonomous control method led to significantly better user performance than the manual control for relatively complex tasks (e.g., knob-turning, ball-picking, and bottle-gasping) that require fine motion control.

Effectiveness of ARMs in Assisting ADLs

There is initial evidence on the utility of ARMs to improve independence and quality of life for people with upper limb impairments. However, the evidence is largely based upon studies conducted in a controlled setting where users were trained to complete discrete and structured tasks instead of functional tasks that they often encounter in everyday life. In a pilot study, we asked 20 able-bodied individuals and 10 powered wheelchair users who were first time ARM users to complete the tasks on ARMET v1.0 and an adapted Wolf Motor Function Test (WMFT) for ARMs using both JACO with joystick control and iARM with keypad control¹⁸. The adapted WMFT includes 8 tasks including hand to table, hand to box, lift weight to box, life can to mouth, life mouth stick, life key, turn key in lock, and life basket to table. Faster task completion time, higher throughput, and lower roughness suggested that the joystick control might be a more efficient control among the participants. For the joystick control, proportional speed control and multi-axial manipulation helped to complete tasks faster. For the keypad control, single-axis action facilitates improved performance for the first-time participants. Even though the performance was statistically different between both controls, there was no statistical difference found in the cognitive loading and user's impressions. The questionnaire reveals that participants viewed both controls as easy to learn and use. Maheu et al. evaluated JACO (Kinova Robotics, Canada) with 34 powered wheelchairs and 31 of them were able to complete the trial¹⁹. Subjects were asked to perform 16 basic movements and 6 tasks (i.e., grasping a bottle on the table, grasping a bottle on a surface near the ground and bring it on the table, pushing the calculator buttons, taking a tissue from a box on the table, pouring water from a bottle into a glass, and taking a straw from a glass on the table). Between 79% and 93% of the participants succeeded to perform the movements and tasks the first time. About two thirds of the participants rated JACO as easy to use and potentially beneficial to assist them in their daily lives. It was also inferred through an economic model that JACO could reduce the caregiving time by 1.31 hours per day. Routhier et al. conducted the only home trial to date with JACO where they asked 7 participants to use JACO for a month²⁰. They found that JACO led to improvements in 9.66.1 tasks based on self-report. Participants were also very satisfied with JACO and perceived an increased quality of life with using it. Unfortunately, they could not record any usage pattern objectively and relied on a logbook for users to report their activities with JACO. According to the authors, the logbook was not completed on a regular basis even with insistent follow-up by the research team.

Summary

ARMs have potentials to assist people with severe upper limb impairments with every manipulation tasks. More work is needed to support the provision process of ARMs and provide evidence on how ARMs can support users to accomplish their priority tasks and expand their abilities to participate in other life activities in in their home and community.

References

1. Hubbard, S.L., Fitzgerald, S.G., Reker, D.M., Boninger, M.L., Cooper, R.A., and Kazis, L.E., Demographic characteristics of veterans who received wheelchairs and scooters from Veterans Health Administration. *J Rehabil Res Dev*, 2006. 43(7): p. 831-44.
2. Simonsick, E.M., Kasper, J.D., Guralnik, J.M., Bandeen-Roche, K., Ferrucci, L., Hirsch, R., et al., Severity of upper and lower extremity functional limitation: scale development and validation with self-report and performance-based measures of physical function. WHAS Research Group. Women's Health and Aging Study. *J Gerontol B Psychol Sci Soc Sci*, 2001. 56(1): p. S10-9.
3. Holliday, P.J., Mihailidis, A., Rolfson, R., and Fernie, G., Understanding and measuring powered wheelchair mobility and manoeuvrability. Part I. Reach in confined spaces. *Disabil Rehabil*, 2005. 27(16): p. 939-49.
4. Snoek, G.J., IJzerman, M.J., Hermens, H.J., Maxwell, D., and Biering-Sorensen, F., Survey of the needs of patients with spinal cord injury: impact and priority for improvement in hand function in tetraplegics. *Spinal Cord*, 2004. 42(9): p. 526-32.
5. Anderson, K.D., Targeting recovery: priorities of the spinal cord-injured population. *J Neurotrauma*, 2004. 21(10): p. 1371-83.
6. Bryden, A., A. Sinnott, and M.J. Mulcahey, Innovative strategies for improving upper extremity function in tetraplegia and considerations in measuring functional outcomes. *Topics in Spinal Cord Injury Rehabilitation*, 2005. 10(4): p. 75-93.
7. Feinberg, L.F., Wolkwitz, K., and Goldstein, C., Ahead of the curve: emerging trends and practices in family caregiver support. National Center on Caregiving: Family Caregiving Alliance. 2006.
8. Atkins, M.S., Baumgarten, J.M., Yasuda, Y.L., Adkins, R., et al., Mobile arm supports: evidence-based benefits and criteria for use. *Journal of Spinal Cord Medicine*, 2008. 31(4): p. 388-393.
9. Choi, Y.S., Andreson, C.D., Glass, J.D., and Kemp, C.C., Laser pointers and a touch screen: intuitive interfaces for autonomous mobile manipulation for the motor impaired, Proceedings of the 10th international ACM SIGACCESS conference on Computers and accessibility - Assets '08. 2008, ACM Press: New York, New York, USA. p. 225.
10. Hammel, J., Hall, K., Lees, D., Van der Loos, M., Perkash, L., and Crigler, R., Clinical evaluation of a desktop robotic assistant. *Journal of rehabilitation research and development*, 1989. 26: p. 1-16.
11. Chung, C.-S., Wang, H.W., Kelleher, A.R., and Cooper, R.A., Development of a standardized performance evaluation ADL task board for assistive robotic manipulators, Proceedings of the Rehabilitation Engineering and Assistive Technology Society of North America Conference. 2013: Seattle, WA.
12. Wang, H., Chung, C.S., Petruskie, B., Ding, D., Kelleher, A. Cooper, R., and Cooper, R.A. Design and development of an assistive robotic manipulation evaluation tool (ARMET). Proceedings of the Rehabilitation Engineering and Assistive Technology Society of North America Conference. 2016. Arlington VA.
13. Chung, C.S., Boninger, J., Wang, H.W., and Cooper, R.A., The Jacontrol: Development of a smartphone interface for the assistive robotic manipulator, RESNA Annual Conference. 2015: Denver, CO.
14. Kim, D.-J., Wang, Z., and Behal, A. Motion segmentation and control design for UCF-MANUS—an intelligent assistive robotic manipulator. *IEEE/ASME Transactions on Mechatronics*, 2012. 17: p. 936-948.
15. Laffont, I., Biard, N., Chalubert, G., Delahoche, L., Marhic, B., Boyer, F.C., and Leroux, C., Evaluation of a graphic interface to control a robotic grasping arm: a multicenter study. *Archives of physical medicine and rehabilitation*, 2009. 90: p. 1740-8.
16. Ka, H., Ding, D., and Cooper, R.A., Three dimensional computer vision-based alternative control method for assistive robotic manipulator. *Int J Adv Robot Automn*, 2016. 1(1): p. 1-6.
17. Ka, H., Chung, C.S., Ding, D., James, K., and Cooper, A., Assistive robotic manipulation performance evaluation between manual and semi-autonomous control. Proceedings of the Rehabilitation Engineering and Assistive Technology Society of North America Conference. 2016. Arlington VA.
18. Chung, C.S., Wang, H.W., Hannan, M.J., Ding, D., Kelleher, A., and Cooper, R.A., Task-oriented performance evaluation for assistive robotic manipulators: a pilot study, *American Journal of Physical Medicine and Rehabilitation*, 2016 (in print)
19. Maheu, V., Frappier, J., Archambault, P., and Routhier, F., Evaluation of the JACO robotic arm: clinico-economic study for powered wheelchair users with upper-extremity disabilities, 2011 IEEE International Conference on Rehabilitation Robotics. 2011, IEEE. p. 1-5.
20. Routhier, F., Archambault, P., Cyr, M.C., Maheu, V., Lemay, M., and Gelinas, I., Benefits of JACO robotic arm on independent living and social participation : an exploratory study. RESNA Annual Conference. 2014: Indianapolis, IN.

Contact Information:

Dan Ding

Human Engineering Research Laboratories
6425 Penn Ave, Suite 400
Pittsburgh, PA 15206
Tel: 412-822-3684
Email: dad5@pitt.edu

PS2.1: Adapting Off-the-Shelf Fitness Wearable for Manual Wheelchair Users

Kalai Tsang, BS
 Hui-Ju Young, PhD
 James H. Rimmer, PhD
 Dan Ding, PhD

Background

There are numerous off-the-shelf fitness wearables that quantify PA in different ways. People choose these wearables depending on their personal interest; for example, an office worker who lives a sedentary life may choose a simple pedometer to track how many steps taken in a day, but a runner may choose a device that provides the speed and distance to improve performance. Regardless of the type, the use of fitness wearables has shown to be significantly associated with increased motivation to engage in more PA, decreased BMI, decreased blood pressure, decreased percent body fat, and long-term behavior changes (Bravata et al., 2007; Fritz, 2014; Hurling et al., 2007; Jauho et al., 2015). While the ambulatory population has access to a plethora of fitness wearables and benefits from using them, manual wheelchair users (MWUs) have very limited choices as research showed most off-the-shelf monitors failed to recognize wheelchair related activities. Tsang et al. (2016) reported the relative errors of predicted energy expenditure (EE) by commercial monitors in MWUs ranged from -62.5% to -48.1% (absolute error: 21.3 – 125.8%) when compared to the gold standard (Tsang, Hiremath, Crytzer, Dicianno, & Ding, 2016); while the errors of estimating EE by tri-axial accelerometer-based and multisensor-based monitors in ambulatory population were -6.85% (95% confidence interval (CI): -18.20 – 4.49%) and 3.64% (95% CI: -8.97 – 1.70%) respectively (Remoorte et al., 2012). It was concluded that further development and modifications were needed to make the off-the-shelf wearables accessible to MWUs in order to promote health and fitness in this population. Therefore, our overall goal is to adapt off-the-shelf wearables for MWUs. In this paper, we outlined the overall process on how we will achieve the goal through building custom algorithms based on different commercial wearables, worn at different body locations, for tracking wheelchair related PA, with a focus on the development and evaluation of the custom algorithms based on two monitors – Sensewear and ActiGraph.

Methods

Adapting off-the-shelf monitors involve three main steps – choosing the wearables, applying the correct algorithms for the chosen wearable, and outputting meaningful information. Figure 1 describes the overall process for making the off-the-shelf wearables accessible to MWUs.

Figure 1. The process of making off-the-shelf wearables accessible to wheelchair users.

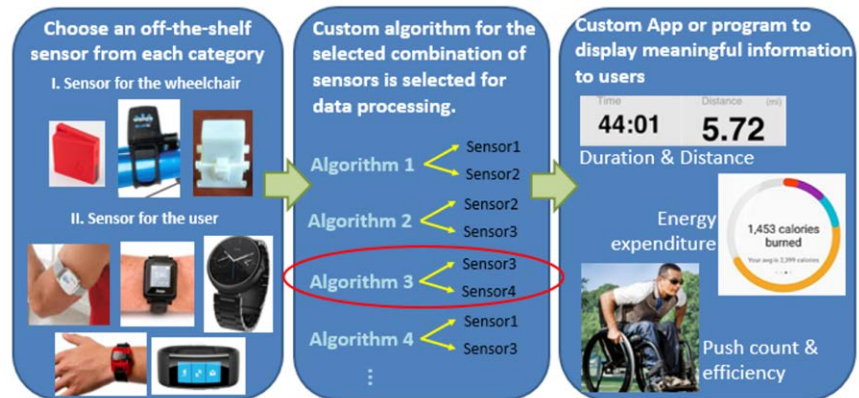

To date, a total of 45 participants have been enrolled in this study. Participants were between 18 and 65 years old, at least 1 year post-injury, lived in the community, used a manual wheelchair as a primary mean of mobility, could propel independently, and were medically stable. Participants were excluded if they were unable to tolerate sitting for three hours, had active pelvic or thigh wounds (pressure ulcers), had a history of cardiovascular diseases, or were pregnant (based on self-report).

Instrumentation

The K4b2 portable metabolic system (COSMED srl, Rome, Italy) was calibrated for each participant following the manufacturer's instructions. The EE measured by the K4b2 served as a criterion measure for the analysis. There were two different kinds of wearables used in this study. ActiGraph GT3X+ (ActiGraph Inc., Pensacola, FL) is an off-the-shelf wearable that consists of a tri-axial accelerometer, an inclinometer for measuring the steepness of slope, and an ambient light photodiode for tracking sleep. SenseWear (Jawbone Inc.) is another off-the-shelf wearable that consists of a tri-axial accelerometer, a galvanic skin response sensor, a skin temperature sensor, and a near-body temperature sensor. All the wearables and K4b2 were time synchronized and worn by participants during the testing trials.

Procedure

The study has two sessions – lab and home. The lab sessions took place at the laboratory facility at the University of Pittsburgh and the Lakeshore Foundation facility in Birmingham, AL. The home sessions took place at participants' home in Pittsburgh, PA and at the Cottage of Lakeshore in Birmingham, AL.

Lab session

Each participant was asked to complete a demographic questionnaire that included information such as age, gender, type of injury, experience using a manual wheelchair, and dietary/exercise habits. Participants wore the K4b2 over the chest with a vest-like harness, two ActiGraph GT3X+ devices (one over the triceps and one on the wrist of the dominant arm, and a SenseWear device over the triceps of non-dominant arm while performing the testing activities. Before beginning the activity trials, participants were asked to rest in their own wheelchairs for 30 min for collecting resting metabolic values. Participants then chose at least 6 activities which they felt comfortable performing from a list of 15 activities, including propulsion at different speeds and over different terrains, arm ergometry exercise at different intensities, and adaptive sports such as basketball and racing. Participants performed each activity for at least 10-min, and were given a 5-min break between activities.

Home session

All participants were invited to the home session, which was scheduled within 3 months of their lab sessions. Similar to the lab sessions, participants wore the same instruments, started with resting periods, and then performed a series of daily and/or household tasks such as watching TV, washing dishes, cleaning the houses, reading, and home exercises such as chair aerobic, stretching, and resistance training. Instructional videos were provided to participants who decided to do home exercises. Participants were given enough time to finish each task they chose, and performed the activities continuously without breaks for 1.5 hours.

Data Analysis

All data from wearables were downloaded at 15s epoch. A custom MATLAB program was written to condense the data into 1-minute intervals. To develop custom EE prediction algorithms, participants were stratified into two groups based on body weight and gender. Eighty percent of them were in the training group, and twenty percent were in the validation group. In addition to the default output from the wearables and demographic information of participants, we created custom variables for developing the algorithms. The custom variables were created using a combination of the default output and demographic data, transforming the default output from the wearables and demographic data, and using a combination of the transformed default output and demographic data. Only the custom variables that showed moderate to strong linear correlation with the criterion EE measured by the K4b2 were used. Custom MATLAB programs were written to select the best combination of variables through an iterative process, and the leave-one-out cross-validation was implemented in the algorithms training process to prevent overfitting. After development, the models were tested with the validation group. The relative percent error, absolute percent error, and the Pearson's *r* coefficient were calculated.

Findings

Custom algorithms for SenseWear

Two sets of custom algorithms were developed, i.e., general and activity-specific algorithms. The general algorithm was developed to estimate EE when wheelchair users performed any kind of PA. The activity-specific algorithms were developed to give a more accurate EE estimation when wheelchair users performed one of the four common wheelchair related PA – resting, deskwork, wheelchair propulsion, and arm ergometry. Results indicated that both the general and activity-specific models showed significant improvement in estimating EE in wheelchair users when compared to the default models used by the SenseWear (S. Hiremath, Ding D, Farrington J, Cooper R, 2012). The average EE estimation error for various PA varied from -19.10% to -89.85%, from -18.13% to 25.13%, and -4.31% to 9.93% for SenseWear default, the custom general, and the custom activity-specific algorithms, respectively (Table 1) (S. Hiremath, Ding D, Farrington J, Cooper R, 2012). The intraclass correlation coefficient was 0.64 (95% confidence interval (CI) 0.57 – 0.70), 0.72 (95% CI: 0.66 – 0.77), and 0.86 (95% CI: 0.82 – 0.88) for default, general, and activity-specific models respectively (S. Hiremath, Ding D, Farrington J, Cooper R, 2012).

Activities	MSE (kcal/min)			Mean Percentage Difference (%)		
	Manufacturer's Model	General Model	Activity-Specific Model	Manufacturer's Model	General Model	Activity-Specific Model
Resting	-0.2±0.3	-0.1±0.5	0.0±0.3	-19.1±27.5	-8.3±34.9	-4.3±21.4
Propulsion	-3.0±2.0	-0.4±0.8	0.2±0.7	-89.8±64.5	-16.8±28.0	2.8±22.3
Arm ergometry	-1.7±2.0	1.3±1.0	0.6±1.0	-40.3±42.1	25.1±16.5	9.9±19.0
Deskwork	-0.4±0.5	-0.2±0.4	0.0±0.2	-34.6±34.4	-18.1±26.8	-0.4±16.1
All activities	-1.9±2.0	0.4±1.1	0.4±0.8	-55.3±56.1	2.3±31.7	4.9±20.7

NOTE. Values are mean ± SD. The 95% confidence interval MSE values for the manufacturer's, and new general and activity-specific models were -48.1% to -62.5%, 6.3% to -1.7%, and 7.5% to 2.2%, respectively, for all activities combined.

Table 1. MSE and mean percent difference of EE (kcal/min) using the SenseWear default models, the custom general model, and the custom activity-specific models for the validation group. (1)

References

Hiremath S, Ding D, Farrington J, Cooper R. Predicting Energy Expenditure of Manual Wheelchair Users with Spinal Cord Injury Using a Multisensor-based Activity Monitor. *Arch Phys Med Rehabil.* 2012;93(11):1937-43. doi: 10.1016/j.apmr.2012.05.004.

In addition, a set of classification algorithms were developed to recognize 4 different wheelchair-related activities – resting, deskwork, wheelchair propulsion, and arm ergometry. This set of algorithms helped classify PA so that the correct activity-specific models mentioned earlier could be applied to better estimate EE in wheelchair users. Two different methods including quadratic discriminate analysis (QDA) and Naïve Bayes (NB) were used. The classification accuracy was 96.3% for QDA and 94.8% for NB when tested on a validation data set. The average EE estimation error using the activity-specific algorithms were 5.3 +/- 21.5% and 4.6 +/- 22.8% when the QDA and NB algorithms were applied, respectively, which were comparable to the error (4.9 +/- 20.7%) when 100% classification accuracy was assumed (S. Hiremath, Ding, Farrington, Vyas, & Cooper, 2013). We further evaluated the custom algorithms in estimating

the duration in different activity intensity levels. Figure 2 shows an example of the duration of activities in each intensity level measured by the K4b2, and estimated by the custom general and the activity-specific algorithms. Overall, the custom general and activity-specific algorithms overestimated the duration of low intensity (<3 MET) activities, and underestimated the duration of moderate (3 – 6 MET) and vigorous intensity (>6 MET) activities (Table 2). The relative percent error of the custom general algorithm for low, moderate and vigorous intensity activities were -26.4%, 55.5%, and 50%, respectively, and that of the custom activity-specific algorithms were -22.9%, 54.1%, and 40%, respectively. The relatively high prediction error in moderate and vigorous intensity activities was due to the relatively short duration at those intensity levels (small dataset).

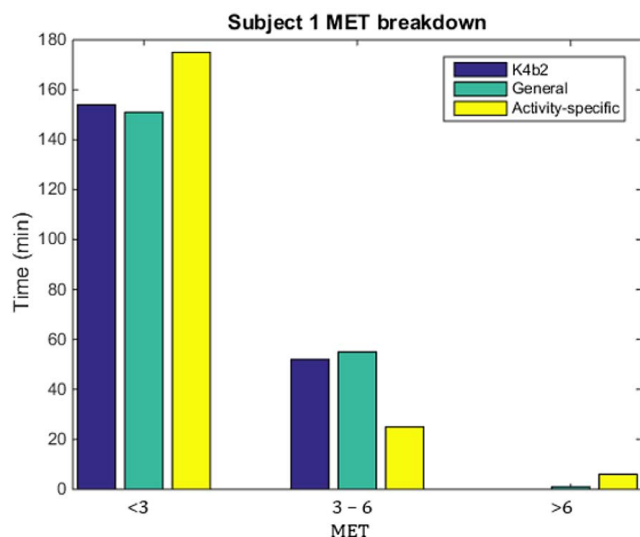

Figure 2. A study participant’s time spent in activities in each of the three intensity levels.

Intensity level	The average time spent (min) in each intensity level among participants			Difference (min) from the gold standard	
	K4b2	General	Activity-Specific	General	Activity-Specific
<3 MET	125.0 ± 39.8	158.0 ± 23.2	153.6 ± 25.6	-33.0 ± 29.8	-28.6 ± 37.2
3 – 6 MET	55.8 ± 28.7	24.8 ± 22.7	25.6 ± 3.1	31.0 ± 29.3	30.2 ± 31.1
>6 MET	2.0 ± 4.5	1.0 ± 0	1.2 ± 2.7	1.0 ± 4.5	0.8 ± 5.8

*Negative values mean overestimation.

Table 2. The time spent (min) in each intensity level measured by the K4b2, the general, and the activity-specific algorithms.

Custom algorithms for ActiGraph

Two sets of two custom algorithms (i.e., sedentary and active) were developed based on Actigraph worn on the upper arm and at the wrist. The sedentary algorithm was developed to estimate EE when wheelchair users performed relatively low intensity PA such as reading, watching TV, and initial start of intense PA, e.g., the start of wheelchair racing. The active algorithm was developed to estimate EE when wheelchair users performed relatively high intensity

PA such as wheelchair basketball, racing and weight lifting. A custom MATLAB program was written to first classify PA into either sedentary or active based on the default output – activity counts – from ActiGraph, and then applied to the corresponding estimation algorithm. For the upper arm, the mean percent errors were -5.5 +/- 19.2%, -7.0 +/- 14.3%, and 16.9 +/- 273.5% for the sedentary, active, and default algorithms, respectively when tested in the validation group (Table 3). For the wrist, the mean percent errors were -11.3 +/- 21.9%, -10.9 +/- 23.5%, and 20.8 +/- 314.2% for sedentary, active, and default algorithms, respectively (Table 3). Results showed that both custom sedentary and active algorithms performed better than the default ActiGraph algorithm in estimating EE in wheelchair users.

	Wrist	Upper arm
Sedentary	-11.3 ± 21.9%	-5.5 ± 19.2%
Active	-10.9 ± 23.5%	-7.0 ± 14.3%
Default ActiGraph	20.8 ± 314.2%	16.9 ± 273.5%

Table 3. Mean percent error of estimated EE (kcal/min) by sedentary, active, and default ActiGraph algorithms at wrist and upper arm locations when compared to the criterion.

Discussion and Conclusion

Two off-the-shelf wearables have been evaluated, and 3 sets of custom algorithms were successfully developed and validated – they were for the SenseWear and the ActiGraph worn at the upper arm, and the ActiGraph worn at the wrist. All 3 sets of algorithms showed fair validity. Next, we will develop custom algorithms for other wearables such as chest-worn monitor, ActiHeart (CamNtech Ltd, UK). We will continue recruiting participants for our study and use the data for developing and refining the algorithms. Meanwhile, we will be exploring the possibilities of adapting other wearable devices such as SensorTag, Microsoft band, Moto 260 android watch, and Panobike speed/cadence sensor. These wearables are relatively inexpensive, ranging from \$30 to \$250, and they have high customizability. We are hoping to incorporate our custom algorithms into these devices, which will greatly increase the variety of off-the-shelf wearables available to MWUs in the future. We will be testing the compatibility of the raw data from these alternative fitness wearables with the devices we have been using, and then apply our developed/validated algorithms via custom phone Apps or open-source software. Finally, we will evaluate the ability of the wearables in detecting changes in activity level. We hope the wearables will be able to promote a more active lifestyle in MWUs, but the sensitivity of these off-the-shelf devices and our custom algorithms in detecting changes in activity level remains unclear. A valid and sensitive tool that can track changes of activity level (if any) of an individual is crucial in supporting future research on effectiveness of physical activity interventions.

References

1. Bravata, D., Smith-Spangler, C., Sundaram, V., Gienger, A., Lin, N., Lewis, R., . . . Sirard, J. (2007). Using Pedometers to Increase Physical Activity and Improve Health: A Systematic Review. *The Journal of American Medical Association*, 298(19), 2296 - 2304. doi:10.1001/jama.298.19.2296
2. Fritz, T., Huang EM, Murphy GC, Zimmermann T. (2014). Persuasive Technology in the Real World: A Study of Long-Term Use of Activity Sensing Devices for Fitness. Paper presented at the SIGCHI Conference on Human Factors in Computing Systems, Toronto, Canada.
3. Hiremath, S., Ding, D., Farrington, J., Vyas, N., & Cooper, R. (2013). Physical activity classification utilizing SenseWear activity monitor in manual wheelchair users with spinal cord injury. *Spinal Cord*, 51(9), 705 - 709. doi:10.1038/sc.2013.39
4. Hiremath, S., Ding D, Farrington J, Cooper R. (2012). Predicting Energy Expenditure of Manual Wheelchair Users with Spinal Cord Injury Using a Multisensor-based Activity Monitor. *Arch Phys Med Rehabil.*, 93(11), 1937-1943. doi:10.1016/j.apmr.2012.05.004
5. Hurling, R., Catt, M., Boni, M., Fairley, B., Hurst, T., Murray, P., . . . Sodhi, J. (2007). Using Internet and Mobile Phone Technology to Deliver an Automated Physical Activity Program: Randomized Controlled Trial. *Journal of Medical Internet Research*, 9(2), e7. doi:10.2196/jmir.9.2.e7
6. Jauho, A., Pyky, R., Aho, R., Kangas, M., Virtanen, P., Korpelainen, R., & Jamsa, T. (2015). Effect of wrist-worn activity monitor feedback on physical activity behavior: A randomized controlled trial in Finnish young men. *Preventive Medicine Reports*, 2, 628 - 634. doi: 10.1016/j.pmedr.2015.07.005
7. Remoortte, H., Giavedoni, S., Raste, Y., Burtin, C., Louvaris, Z., Gimeno-Santos, E., . . . Troosters, T. (2012). Validity of activity monitors in health and chronic disease: a systematic review. *International Journal of Behavioral Nutrition and Physical Activity*, 9(84). doi:10.1186/1479-5868-9-84
8. Tsang, K., Hiremath, S. V., Crytzer, T. M., Dicianno, B. E., & Ding, D. (2016). Validity of Activity Monitors in Wheelchair Users: A Systematic Review. *J. Rehabil. Res. Dev.*, 53(In press).

Contact Information:

Kalai Tsang

Human Engineering Research Laboratories
6425 Penn Ave, Suite 400
Pittsburgh, PA 15206
Tel: 412-822-3706
Email: kat85@pitt.edu

PS2.2: Assessment of Seat Elevator User Satisfaction

Vince Schiappa, MS

Geoffrey Henderson, MD

Corey Hickey, DO

Richard Schein, PhD, MPH

Mark Schmeler, PhD, OTR/L, ATP

Brad Dicianno, MD

The purpose of this study was to assess the difference in satisfaction of function while using seat elevators on power wheelchairs among individuals with disabilities through retrospective analysis of two databases that included time 1 and time 2 Functional Mobility Assessment (FMA) scores. Three aspects of the FMA were assessed; #5 (reach), #6 (transfer), and total score.

Learning Objectives:

Upon completion of this session, attendees will be able to;

- Discuss the three different analyses performed.
- List the three different FMA items utilized.
- Discuss the significance of the nine results.

References:

1. Arva, J., Schmeler, M.R., Lange, M.L., Lipka, D.D., & Rosen, L.E. (2005). RESNA Position on the Application of Seat-Elevating Devices for Wheelchair Users. *Assistive Technology: The Official Journal of RESNA*. 21(2), 69-72.
2. Kumar, A., Schmeler, M.R., Karmarkar, A.M., Collins, D.M., Cooper, R., Cooper, R.A., & Holm, M.B. (2013). Test-retest reliability of the functional mobility assessment (FMA): a pilot study. *Disability and Rehabilitation Assistive Technology*. 8(3), 213-219.
3. Sabari, J., Shea, M., & Chen, L. (2016). Impact of Wheelchair Seat Height on Neck and Shoulder Range of Motion during Functional Task Performance. *Assistive Technology: The Official Journal of RESNA*.

PS2.3: Evaluating Wheelchair Transfer Technique by Microsoft Kinect

Lin Wei, MS

Tyler Brown, MS

Hyun Ka, PhD

Alicia M. Koontz, PhD, RET

Abstract

Improper transfer technique predisposes wheelchair users (WUs) to upper arm pain and injuries. Education of proper technique is not well disseminated and clinicians have limited time to work with WUs to develop their skills. Microsoft Kinect is a low-cost marker-less motion capture device with the ability to detect body motion and may serve as a tool that could assist clinicians and WUs with practicing and learning proper transfer technique. The purpose of the current study is to 1) associate the Kinect motions during wheelchair transfers with a gold standard measure of transfer quality (Transfer Assessment Instrument (TAI)), 2) develop discriminant analysis that relate the Kinect variables to the TAI scores, 3) validate the Kinect's accuracy for determining if a patient is using proper or improper transfer technique. Fifty-five full time WUs performed five sitting pivot transfers from their wheelchair to a level height bench. A trained investigator scored the TAI and the Kinect simultaneously recorded the body's motion data for each transfer. The associations between the transfer motions, subject anthropometrics, and TAI's component item scores were examined using discriminant analysis. Leave-one-out cross-validation was used to investigate the accuracy of the models. The Kinect model was able to predict clinician outcomes 83.6% to 93.1% of the time. The specificities are 77.9% to 97.8%, and the positive predictive values are 85.8% to 99.5%. Thus, the Kinect appears to be a potential tool for wheelchair transfer evaluation.

Introduction

Currently in the United States, there are around 282,000 people with spinal cord injuries ("Annual Statistical Report – Facts and Figures at a Glance," 2016), and over 3.6 million Americans aged 15 and over used a wheelchair in 2010 ("Americans With Disabilities: 2010", 2010). Wheelchair users independently transfer from their wheelchairs to other surfaces around 14 to 18 times a day on average (Finley, et al. 2005). For persons who are unable to bear weight through their legs, the majority of the force involved in lifting the body is placed upon the joints in the upper extremities (Fliess-Douer, et al. 2012). Due to this unusual, high magnitude stressor on their upper extremities, many wheelchair users develop repetitive strain injuries such as carpal tunnel syndrome and rotator cuff tears (Dalyan, et al. 1999, Paralyzed Veterans of America Consortium for Spinal Cord, 2005, van Drongelen et al. 2006). The consequence of this is an over-arching decrease in

their quality of life. This lesser quality of life manifests itself as a loss of autonomy and a decreased ability to participate in society (Gerhart, et al. 1993, Lundqvist, et al. 1991, Rintala, et al. 1998). One approach to minimize these injuries is to teach wheelchair users how to transfer in order to decrease the torques on the upper extremities. Torque-minimization will be dictated by how the wheelchair user moves during the transfer. The Transfer Assessment Instrument (TAI) is a clinical tool for measuring transfer quality that correlates well with the biomechanics of transfers (Tsai, et al. 2014). The TAI is a series of yes or no questions that evaluates both the wheelchair user's overall technique and any weak component skills within the transfer (McClure, et al. 2011, Tsai et al. 2013). A high TAI score signifies lower mechanical loads on the joints of the upper extremities (Tsai, et al. 2014). Thus, patients who learn to perform transfers that are consistent with a high TAI score may be less prone to developing upper extremity pain and injuries over time. However, the TAI requires that wheelchair users be assessed and trained by a clinician familiar with TAI to know if their transfer was performed correctly or not.

The Microsoft Kinect is a markerless motion capture sensor used predominantly in the gaming industry and more recently in a wide variety of rehabilitation applications (Bonnechère, et al. 2014, Pedraza-Hueso, et al. 2015). The Microsoft Kinect has been shown to be a reliable and valid tool for assessing human trunk lean and posture (R.A. Clark, et al. 2013, R.A. Clark, et al. 2015, Kiselev, et al. 2015) and preliminary work has shown it may be useful for tracking transfer motions (Wei, et al. 2016).

The purpose of this study is to develop and test Kinect-based models for classifying proper and improper transfer technique. A Kinect-based coaching system could provide an alternative to one-on-one transfer technique training with a clinician, reducing the clinical time needed and number of clinical visits. We aim to 1) associate the Kinect motions during wheelchair transfers with TAI as a gold standard measure of transfer, 2) develop discriminant analysis that relate the Kinect variables to the TAI scores, 3) validate the Kinect's accuracy for determining if a patient is using proper or improper transfer technique.

Methods

Participation

The study was approved by the Department of Veterans Affairs Institutional Review Board. Testing was conducted at the National Disabled Veterans Winter Sports Clinic in Snowmass, CO, April 2016, and the 36th National Veterans Wheelchair Games in Salt Lake City, UT, July 2016. Each wheelchair user tested had to meet the following criteria: (1) older than 18 years old, (2) one year after injury or diagnosis, (3) use a wheelchair for at least 35 hours/week, and (4) be unable to stand up without support. Wheelchair users were excluded from the study if they had pressure sores within the last year or had a history of angina or seizures.

Testing Protocol

Demographic information such as age, height, weight and year using a wheelchair were collected for each subject, as well as subject's anthropometric measurements (e.g. segment lengths and circumferences). Subjects were asked to position their chairs as they normally would before the transfer, and

then to transfer to and from a tub bench in their habitual way. Five transfers to/from the bench were collected while the TAI and Kinect were being recorded. Subjects were given a chance to familiarize themselves with the setup prior to being asked to transfer. A trained TAI rater evaluated each transfer. The Kinect sensor was positioned two meters in front of the subjects, seventy centimeters above the floor, and centered between the wheelchair and the bench. A custom data collection software was used to collect the 3D joint center position data.

Data Analysis

Table 1. Body Segment Vectors

Joint centers defined by the Kinect sensor.
<https://msdn.microsoft.com/en-us/library/microsoft.kinect.jointtype.aspx>

Body Segment Vectors	Kinect Locations
Global Y	Y-axis
Trunk	Spine Shoulder Spine Mid
Shoulder Across	Shoulder Right Shoulder Left
Trunk Anterior*	Cross product of: Trunk and Shoulder Across
Upper Arm	Shoulder Elbow
Forearm	Elbow Wrist
Shoulder to Wrist	Shoulder Wrist
Wrist to Hand	Wrist Hand
Wrist to Hand Tip	Wrist Hand Tip
Wrist to Thumb	Wrist Thumb
Thigh	Hip Knee
Hip Across	Hip Right Hip Left
Shoulder Across Transverse	Shoulder Across projected onto Transverse Plane
Hip Across Transverse	Hip Across projected onto Transverse Plane
Shoulder Across Frontal	Shoulder Across projected onto Frontal Plane
Hip Across Frontal	Hip Across projected onto Frontal Plane
Mid Spine Hip	Spine Mid Spine Base
Head Hip	Head Spine Base

*Trunk Anterior is calculated as the cross product of the trunk and shoulder across vectors. Thus, it is a vector that starts at their chest and points out to the front.

Table 2. Joint Motion Angles

Joint Motion Angle	Vectors
Shoulder POE	Trunk Anterior Upper Arm
Shoulder to Wrist POE	Trunk Anterior Shoulder to Wrist
Shoulder Elevation	Trunk Upper Arm
Shoulder to Wrist Elevation	Trunk Shoulder to Wrist
Elbow Flexion	Upper Arm Forearm
Wrist Flexion	Forearm Wrist to Hand
Wrist Flexion Tip	Forearm Wrist to Hand Tip
Trunk Flexion	Trunk Thigh
Trunk Bending - Raw	Shoulder Across Hip Across
Trunk Bending – Transverse Plane	Shoulder Across Transverse Hip Across Transverse
Trunk Bending – Frontal Plane	Shoulder Across Frontal Hip Across Frontal
Trunk Y-axis vs. Spinebase to Midspine	Global Y MidSpine Hip
Trunk Y-axis vs. Spinebase to Head	Global Y Head Hip
Other Metrics	Vectors Used
Hand Area*	Wrist to Thumb Wrist to Hand Tip
Head Hip Velocity**	Head Hip
Head Hip Acceleration**	Head Hip

Vectors used for the calculation of joint motion angles.

* Hand area is a calculation of the area between the vectors of the Wrist to Hand Tip and the Wrist to Thumb.

** Head-Hip Velocity and Acceleration reference the speed at which a subject's hips move with respect to their head, and this is most directly measured using the Head Hip vector.

Body segment vectors were created utilizing the 3D joint center position data (Table 1). Joint angles were calculated between these vectors (Table 2). Hand Area and Head-Hip Velocity and Acceleration were also computed. Maximum (Max), minimum (Min), range of motion (ROM), and average (Avg) values were calculated over the entire transfer (start to finish). These same variables were also computed during the pre-lift phase of transfer (one third of a second prior to transfer) for each subject and each trial.

The TAI contains two parts. Part 1 of the TAI looks at individual components of a transfer. Only five items from part 1 were included in this study, because they are associated with motions of the upper extremities and the trunk which the Kinect can measure. Other items that concern wheelchair setup, such as the distance between the wheelchair and the surface, were not included in this study because the Kinect cannot measure them. Part 2 of the TAI was also not analyzed because it encompasses some of the same transfer skills that are measured in part 1. The items include: how subjects' hands are positioned prior to the transfer, if a handgrip is utilized by both the leading arm and trailing arm and item, and if the leading arm is correctly positioned. The TAI part

1, item 12, use of a correct head-hip relationship throughout the movement, was separated into two sub-items 1-12a and 1-12b. Sub-item 1-12a determines if the subject leaned forward enough, and sub-item 1-12b determines the subject's head and hips move in opposite directions. Items are scored "yes" (1 point) when the subject performs the specified skill correctly and "no" (0 points) when the subject performs the skill incorrectly. The researcher who analyzed the Kinect data was blinded to the TAI scores during the analysis phase.

Subjects were separated into two groups (proper and improper technique) based on their TAI item scores (1 and 0). Descriptive statistics (group means and standard deviations) were calculated for all variables. An independent t-test was used to examine group differences for the Kinect variables. Point-biserial correlation tests were used to assess the strength of the relationship of each Kinect variable with the TAI scores. Variables that were significantly different between groups and that had at least a moderate correlation with the TAI score ($r_{pb} = 0.25$ or higher) were entered into a discriminant analysis which allows for a prediction of a TAI score based upon a new subject's Kinect observations. In addition, anthropometric variables that were related to the TAI score were also entered as independent variables in the analysis. The resulting discriminant functions were analyzed for their ability to accurately predict a TAI score via a leave-one-out cross-validation method. The numbers of true positives and negatives and false positives and negatives were used to calculate each model's sensitivity, specificity, positive and negative predictive values (PPV and NPV). All the statistical analyses were performed in SPSS 23 (SPSS Inc., Chicago, IL).

Results

Participants

Table 3. Subject's demographic data and wheelchair experience.

Items	Avg. (Range)
Age (years)	54.07 (35-81)
Wheelchair Experience (years)	15.63 (2-42)
Hours Spending on Wheelchair per day	11.95 (2.50-19.00)
Number of Level Transfer Performed per day	10.29 (0-30)
Number of Non-level Transfer Performed per day	5.96 (0-16)
Weight (kg)	84.54 (46.27-126.10)
Height (cm)	176.50 (152.40-194.31)
BMI	27.17 (18.47-39.99)

Fifty-five wheelchair users participated in this study. Eight subjects were female and 47 were male. Thirty-nine subjects had spinal cord injuries, five subjects had multiple sclerosis, nine amputees, one had Guillain-Barre syndrome, and one had both a spinal cord injury and an amputation. The study included 45 manual wheelchair, eight power wheelchair, and two scooter users. Table 3 shows the subjects' demographic

data and their wheelchair experience.

Modeling Results

Table 4. Classification results of TAI by each item. "0" means the improper transfer technique and "1" means the proper technique scored by TAI. The percentage shows the distribution between improper and proper techniques. "# of the factor" shows how many predictor variables were used in each discriminant function to predict the TAI item scores. The overall accuracy shows the proportion of the true positive and true negative outcomes (correctly classified). Model overall accuracies of leave-one-out cross-validation ranged from 83.6% to 93.1% (Table 4), with item 1-10 being the least accurate and item 1-8 being the most accurate. Similarly for specificity the range was 76.8% to 97.8% with 1-12b having the least specificity and item 1-8 having the largest specificity. For PPV the range was 85.8% to 99.5% with 1-12b having the least specificity and item 1-8 having the largest PPV.

Table 4. Clinically important predictor variables and descriptive in discriminant analysis of each TAI item. Maximum (Max), minimum (Min), range of motion (ROM), and average (Avg) values were calculated during the entire transfer. The initial position values were calculated during the pre-lift phase of transfer (one third of a second prior to transfer).

TAI item	N		%		# of Factor	Leave-One-Out Cross-Validation				
	improper	proper	improper	proper		Overall accuracy	Sensitivity	Specificity	PPV	NPV
1-8 Hand position	46	194	19.2%	80.8%	29	93.1%	92.1%	97.8%	99.5%	71.4%
1-9 Leading Handgrip	78	161	32.6%	67.4%	25	92.7%	95.7%	86.7%	93.6%	90.7%
1-10 Trailing Handgrip	105	135	43.8%	56.3%	19	83.6%	80.6%	87.8%	90.2%	76.5%
1.13 Leading Arm Position	58	182	24.2%	75.8%	22	87.3%	90.3%	77.9%	92.6%	72.6%
1-12a Leaning forward	92	148	38.3%	61.7%	28	87.6%	88.7%	86.0%	90.9%	82.9%
1-12b Head-Hip Direction	87	153	36.3%	63.8%	20	88.4%	96.3%	76.8%	85.8%	93.5%

The discriminant functions developed for predicting TAI scores were all statistically significant ($p < 0.001$, Table 4). Item 1-8 shows that subjects who performed the "Hand Position" portion of the TAI item correctly had lower shoulder POE angles on the leading arm, lower shoulder to wrist POE angles on the trailing arm, smaller trunk flexion angles, and

Discussion

Using the Kinect, transfer kinematics information can be gathered and combined with anthropometric information to predict the subject-specific TAI scores. This model was highly accurate, with an accuracy $\geq 83.6\%$, high sensitivity (80.6-96.3%) and PPV (85.8-99.5%) and moderate specificity (76.8-97.8) and NPV (71.4-93.5%) for the TAI items. In clinical practice, it is much more detrimental to diagnose a false-positive TAI score (e.g. saying that the patient is doing it right when they are actually doing it wrong) than to diagnose a false-negative TAI score (e.g. saying that the patient is wrong when they are doing it right). Thus we aim to achieve high specificity and PPV in this study, which will minimize the false-positive TAI scores. We found that our method using the Kinect had both high specificity ($\geq 76.8\%$) and higher PPV than NPV. Altogether, our results demonstrate that the Kinect model may be an effective assessment tool. This is because the model is

very unlikely to tell a patient they are doing the movement correctly when they are actually doing it incorrectly. This ability may be valuable to a clinician because incorrect behaviors are not reinforced as though they were correct. Using our Kinect model, we were able to predict four TAI items and two sub-items scores ($p < 0.001$). The significant predictor variables were consistent with the movement patterns that would be expected for each TAI item. For example, for TAI 1-8 we found that placing the leading arm and trailing hand more anterior to the trunk was consistent with proper technique. Keeping the trailing arm close to the edge of the wheelchair seat before the transfer (Trailing Shoulder to Wrist POE) and reaching the leading arm out more towards the edge of the bench (towards where they would land on the target surface - Leading Shoulder POE) was also related to scoring well on this item. These results agree with the TAI item criteria, which states: "Hands are in a stable position prior to the start of the transfer, push off (trailing) hand is close to the body, and leading hand is close to where he will be landing."

The Kinect sensor provides coordinate data for the location of the wrist, thumb, and hand tip. By calculating the area of a triangle using the three joint/segment locations as the vertices, item 1-9 and 1-10 show that subjects who performed the "Leading Hand Grip" and "Trailing Hand Grip" TAI item correctly have larger hand grip area and wrist flexion angles ($p < 0.042$). A common improper transfer technique is that a subject uses his/her fist to left the body. A proper handgrip (including the edge of the surface -- i.e. mat table, bed, etc) is used in the correct manner if the grip is within the individual's base of support. If no handgrip is available or outside the individual's base of support, the hand should

ITEM 1-8: Hands are in a stable position at the beginning of transfer (model p-value <0.001, total number of predictor variables: 29)						
Variables	Improper		Proper		P-value	Standardized Coefficient
	Mean	SD	Mean	SD		
Max. Leading Shoulder POE (deg.)	106.65	20.62	100.70	12.04	.011	-.876
ROM. Trailing Shoulder to Wrist POE (deg.)	50.66	30.59	40.49	21.46	.009	.651
Max. Trunk Y-axis vs. Spinebase to Midspine (deg.)	47.95	22.61	36.90	11.16	<.001	.630
BMI (kg/m ²)	30.27	6.10	25.91	5.12	<.001	2.810
Body Weight (kg)	88.90	21.35	81.54	15.68	.008	-1.724
ITEM 1-9: A handgrip is utilized correctly by the leading arm (model p-value <0.001, total number of predictor variables: 25)						
Variables	Improper		Proper		P-value	Standardized Coefficient
	Mean	SD	Mean	SD		
Avg. leading Hand Grip Area (mm ²)	3281.81	825.26	3858.36	1397.96	.001	-.338
Max. Leading Shoulder To Wrist POE (deg.)	93.00	14.98	88.49	13.01	.018	.713
Min. Leading Elbow Flexion (deg.)	26.83	12.41	20.90	9.28	<.001	.684
Avg. Leading Wrist Flexion (deg.)	24.45	12.03	31.46	13.61	<.001	-.572
Chest Circumference (cm)	104.03	10.26	108.29	12.10	.008	-1.537
ITEM 1-10: A handgrip is utilized correctly by the trailing arm (model p-value <0.001, total number of predictor variables: 19)						
Variables	Improper		Proper		P-value	Standardized Coefficient
	Mean	SD	Mean	SD		
Avg. Trailing Hand Grip Area (mm ²)	3513.96	1557.1	3902.97	1386.04	.042	.288
Max. Trailing Shoulder to Wrist POE (deg.)	96.16	17.43	91.42	19.66	.053	-.343
Initial Position of Trailing Shoulder Elevation (deg.)	25.48	11.19	32.93	19.16	<.001	.284
Trailing Wrist Circumference (cm)	18.01	1.13	16.87	1.93	<.001	-1.052
Waist Circumference (cm)	112.00	16.06	104.81	14.47	<.001	-.726
ITEM 1-13: The lead arm is correctly positioned (model p-value = <0.001, total number of predictor variables: 22)						
Variables	Improper		Proper		P-value	Standardized Coefficient
	Mean	SD	Mean	SD		
Avg. Leading Shoulder Elevation (deg.)	57.73	11.87	49.31	12.69	<.001	.249
Max. Leading Shoulder Elevation (deg.)	92.92	20.08	75.90	19.04	<.001	.813
Max. Leading Shoulder to Wrist Elevation (deg.)	68.06	18.08	60.03	15.59	.001	-.612
Initial Position of leading Elbow Flexion (deg.)	52.83	15.19	43.86	14.72	<.001	.401
ROM Trunk Y-axis vs. Spinebase to Midspine (deg.)	31.53	12.92	26.17	10.35	.001	.530
ITEM 1-12(a): The subject is leaning forward properly (model p-value = <0.001, total number of predictor variables: 28)						
Variables	Improper		Proper		P-value	Standardized Coefficient
	Mean	SD	Mean	SD		
Initial Position of Trunk Y-axis vs. Spinebase to Head (deg.)	14.05	7.33	26.43	17.90	<.001	-4.388
Max. Trunk Y-axis vs. Spinebase to Head (deg.)	30.34	7.59	45.52	16.74	<.001	-2.553
Initial Position of Trunk Y-axis vs. Spinebase to Midspine (deg.)	13.10	6.90	24.93	15.40	<.001	4.252
Max. Trunk Y-axis vs. Spinebase to Midspine (deg.)	29.54	7.60	44.91	14.96	<.001	2.849
Avg. Head Hip Velocity (m/s)	0.51	0.24	0.60	0.30	.017	-.363
ITEM 1-12(b): The head moves in the opposite direction of the hips (model p-value = <0.001, total number of predictor variables: 20)						
Variables	Improper		Proper		P-value	Standardized Coefficient
	Mean	SD	Mean	SD		
Avg. Head Hip Velocity (m/s)	0.51	0.18	0.59	0.32	.024	-.249
Max. Trunk Y-axis vs. Spinebase to Head (deg.)	31.27	8.18	43.43	15.73	<.001	-.484
Max. Trunk Bending Angle - Frontal Plane (deg.)	17.74	6.93	21.77	15.47	.022	-.281
Max. Trailing Shoulder To Wrist Elevation (deg.)	51.77	14.58	65.37	23.81	<.001	-.400
Trunk Length (cm)	57.06	9.74	53.37	6.68	.001	.461

lower BMI and body weight. Item 1-9 shows that subjects who performed the "Leading Hand Grip" TAI item correctly had larger hand grip area, lower shoulder to wrist POE angles, lower elbow flexion angles, larger wrist flexion angles on their leading arm, and wider chest circumference. Item 1-10 shows that subjects who performed the "Trailing Hand Grip" TAI item correctly had larger hand grip area, lower shoulder to wrist POE angles, larger shoulder elevation angles on their trailing arm, and larger wrist and waist circumference. Item 1-13 shows that subjects who performed the "Leading Arm Angle" portion of the TAI item correctly had lower shoulder elevation angles, shoulder to wrist elevation angles, elbow flexion angles on the leading arm, and had less trunk flexion. Item 1-12a shows that subjects who leaned forward correctly leaned forward more at the beginning and during the transfer, and had higher head-hip velocity. Item 1-12b shows that subjects who moved their head in the opposite direction of the hips created a higher head hip velocity, had more flexion and bending of trunk motion angles, higher shoulder to wrist elevation angles on the trailing arm, and longer trunk length.

be placed flat on the transfer surface. Both situations create a larger area of the triangle than using a fist hand. We also found that keeping the arms lower, flexing the elbows less, placing hands more anterior to reach and gripping the edge of the bench or wheelchair rather than placing a fist on the middle of the bench or wheelchair cushion were consistent with a higher score on TAI.

The average shoulder elevation (abduction) angle during the transfer process measured by the Kinect in the proper group was 49.31 deg. (SD=12.69), and the improper group was 57.73 (SD=11.87, $p<0.001$). Performing Item 1-13 ("The lead arm is correctly positioned") portion of the TAI correctly was consistent with less leading shoulder abduction, less elbow flexion, and less trunk (ROM) movement.

Higher ($p<0.024$) head-hip relative velocity (velocity of hips motion with respect to their head) and larger trunk flexion angle was associated with proper performance of item 1-12a and 1-12b ($p<0.001$). TAI part1, item 12 is "Head-hip relationship is used". For the Item 1-12a, proper technique was associated with leaning forward more at the beginning and during the transfer process. For item 1-12b, the opposite motion direction of the hip and head was associated with the head-hip relative velocity variable computed by the Kinect. Both results agree with the item criteria.

There are many anthropometric variables that were found to be predictor variables in each discriminant function. For example, we found that BMI and body weight were predictors for item 1-8, chest circumference for item 1-9, waist circumference for item 1-10, and trunk length for item 1-12b. This indicates that some anthropometric characteristics may impede a subject's ability to perform proper transfer technique. For example, higher body weight and BMI may make it more difficult to stabilize a transfer, leading to patients putting their arms in improper positions. These anthropometric variables may help to identify individuals who are at higher risk for improper technique. Clinicians and therapists could therefore use these as risk factors, paying special attention to patients with certain anthropometric measurements to ensure proper technique. These results indicate that patient-specific training programs may be needed for the most effective transfer technique.

Even though we have demonstrated good accuracy of the Kinect-based system, it is important to recognize some limitations of this study. One limitation is that our accuracy calculations are based on small sample sizes in both improper and proper groups. Also the sample size in the improper group was smaller than that of the proper group. It is possible that the sample size was not large or representative enough to detect all possible cases of transfer techniques. Increasing the sample size with more subjects will likely increase model accuracy. A discriminant analysis is only one of many approaches that could be used to model the data. Logistic regression, primary component analysis, machine learning, and other types of classification methods could yield more accurate and meaningful results. Further research will likely elucidate the finalized mathematical model for each TAI score's prediction and necessary steps for the utilization of the Kinect for assessing wheelchair transfers. The result shows the Kinect has the potential to identify and quantify body movements during transfers and distinguish proper from improper technique.

Reference

1. Americans With Disabilities: 2010. (2010). Retrieved from <http://www.census.gov/prod/2012pubs/p70-131.pdf>
2. Annual Statistical Report – Facts and Figures at a Glance. (2016). Retrieved from <https://www.nscisc.uab.edu/reports.aspx>
3. Bonnechère, B., B. Jansen, P. Salvia, H. Bouzahouene, L. Omelina, F. Moiseev, V. Sholukha, J. Cornelis, M. Rooze, and S. Van Sint Jan. (2014). Validity and Reliability of the Kinect within Functional Assessment Activities: Comparison with Standard Stereophotogrammetry. *Gait & Posture* 39.1: 593-98.
4. Clark, R. A., Pua, Y.-H., Oliveira, C. C., Bower, K. J., Thilarajah, S., McGaw, R., . . . Mentiplay, B. F. (2015). Reliability and concurrent validity of the Microsoft Xbox One Kinect for assessment of standing balance and postural control. *Gait Posture*, 42(2), 210-213.
5. Clark, R. A., Pua, Y. H., Bryant, A. L., & Hunt, M. A. (2013). Validity of the Microsoft Kinect for providing lateral trunk lean feedback during gait retraining. *Gait Posture*, 38(4), 1064-1066. doi:10.1016/j.gaitpost.2013.03.029
6. Dalyan, M., Cardenas, D. D., & Gerard, B. (1999). Upper extremity pain after spinal cord injury. *Spinal Cord*, 37(3), 191-195.
7. Fliess-Douer, O., Vanlandewijck, Y. C., & Van der Woude, L. H. (2012). Most essential wheeled mobility skills for daily life: an international survey among paralympic wheelchair athletes with spinal cord injury. *Arch Phys Med Rehabil*, 93(4), 629-635. doi:10.1016/j.apmr.2011.11.017
8. Finley, M. A., McQuade, K. J., & Rodgers, M. M. (2005). Scapular kinematics during transfers in manual wheelchair users with and without shoulder impingement. *Clin Biomech (Bristol, Avon)*, 20(1), 32-40. doi:10.1016/j.clinbiomech.2004.06.011
9. Gerhart, K. A., Bergstrom, E., Charlifue, S. W., Menter, R.R., & Whiteneck, G. G. (1993). Long-term spinal cord injury: functional changes over time. *Arch Phys Med Rehabil*, 74(10), 1030-1034.
10. Kiselev, J., Haesner, M., Govercin, M., & Steinhagen-Thiessen, E. (2015). Implementation of a homebased interactive training system for fall prevention: requirements and challenges. *J*
11. *Gerontol Nurs*, 41(1), 14-19. doi:10.3928/00989134-20141201-01
12. Lundqvist, C., Siosteen, A., Blomstrand, C., Lind, B., & Sullivan, M. (1991). Spinal cord injuries. Clinical, functional, and emotional status. *Spine*, 16(1), 78-83.
13. McClure, L. A., Boninger, M. L., Ozawa, H., & Koontz, A. (2011). Reliability and validity analysis of the transfer assessment instrument. *Arch Phys Med Rehabil*, 92(3), 499-508. doi:10.1016/j.apmr.2010.07.231
14. Paralyzed Veterans of America Consortium for Spinal Cord, M. (2005). Preservation of upper limb function following spinal cord injury: a clinical practice guideline for health-care professionals. *J Spinal Cord Med*, 28(5), 434-470.
15. Pedraza-Hueso, Miguel, Sergio Martín-Calzón, Francisco Javier Díaz-Pernas, and Mario Martínez-Zarzuela. (2015). Rehabilitation Using Kinect-based Games and Virtual Reality. *Procedia Computer Science* 75: 161-68.

-
16. Rintala, D. H., Loubser, P. G., Castro, J., Hart, K. A., & Fuhrer, M. J. (1998). Chronic pain in a community based sample of men with spinal cord injury: prevalence, severity, and relationship with impairment, disability, handicap, and subjective well-being. *Arch Phys Med Rehabil*, 79(6), 604-614.
 17. Tsai, C. Y., Hogaboom, N. S., Boninger, M. L., & Koontz, A. M. (2014). The relationship between independent transfer skills and upper limb kinetics in wheelchair users. *Biomed Res Int*, 2014, 984526. doi:10.1155/2014/984526
 18. Tsai, C. Y., Rice, L. A., Hoelmer, C., Boninger, M. L., & Koontz, A. M. (2013). Basic psychometric properties of the transfer assessment instrument (version 3.0). *Arch Phys Med Rehabil*, 94(12), 2456-2464. doi:10.1016/j.apmr.2013.05.001
 19. van Drongelen, S., de Groot, S., Veeger, H. E., Angenot, E. L., Dallmeijer, A. J., Post, M. W., & van der Woude, L. H. (2006). Upper extremity musculoskeletal pain during and after rehabilitation in wheelchair-using persons with a spinal cord injury. *Spinal Cord*, 44(3), 152-159. doi:10.1038/sj.sc.3101826
 20. Wei L, Tsai C, Koontz AM. (2016). Can the Kinect detect differences between proper and improper wheelchair transfer techniques? *Proceedings of the Rehabilitation Engineering and Assi*

PS2.4 Transfer Training for Wheelchair Users with Multiple Sclerosis

Laura A. Rice, PhD, MPT, ATP
Zadok Isaacs, MS; Cherita Ousley, MS
Jacob Sosnoff, PhD

Background:

Transfers are necessary to allow full time seated wheeled mobility device users (SWMDU) to perform essential activities of daily life including, but not limited to, getting in to and out of bed, performing personal hygiene tasks and getting in and out of a vehicle. (Nyland et al., 2000) Performing a transfer is a complex skill: the user must place him/herself in a position of instability to allow for movement but must also appropriately control the movement to prevent falls.(Gagnon et al., 2009) In addition, during a transfer a significant amount of force is placed on the shoulder, a joint designed for mobility, not stability(van Drongelen et al., 2005). Incorrect performance can result in upper extremity injuries and/or falls(Curtis et al., 1995; Rice, Ousley, & Sosnoff, 2015). In addition, Nyland, et al found that maintenance of transfer skills across the lifespan has been found to be associated with increased life expectancy.(Nyland et al., 2000) Thus, leaning how to perform a transfer correctly is essential for the health, safety and well-being of a SWMDU. Unfortunately, due to the progressive nature of Multiple Sclerosis (MS), formal transfer training is often limited and no peer reviewed education protocols exist on which clinicians can base treatment strategies(Rice et al., 2015). Therefore, the purpose of this study is to examine the efficacy of a transfer training program for SWMDU with MS.

Methods:

After receiving IRB approval, 16 SWMDU with MS were recruited by the Disability, Participation and Quality of Life Research Laboratory at the University of Illinois at Urbana-Champaign. Participants were recruited through the North American Research Committee on Multiple Sclerosis (NARCOMS) research registry, posting of flyers and word of mouth. Individuals were invited to participate if they met the following inclusion criteria: a diagnosis of MS; age > 18years old; self-reported Patient Determined Disease Steps(Learmonth, Motl, Sandroff, Pula, & Cadavid, 2013) (PDDS) level of 7 (i.e. main form of mobility is via a wheeled mobility device); self-reported inability to ambulate outside of the home; and self-reported ability to transfer with moderate assistance (participant expends 50-74% of the effort) or less. Exclusion criteria includes; a MS exacerbation in the past 30 days and unable to sit upright for at least 1 hour.

Study participants were invited to participate in two research sessions, 12 weeks apart. At the baseline study visit, after collecting basic demographic information, SWMDU performed 4 transfers to and from a mat bench utilizing their preferred technique. The quality of the transfers was assessed using the Transfer Assessment Instrument (TAI) (Tsai, Rice, Hoelmer, Boninger, & Koontz, 2013). After the baseline assessment, SWMDU were educated on transfer skills by a Physical Therapist. The education intervention focused on improving the quality of transfer skills. Instruction was provided by showing study participants a 10-minute video on transfer techniques. During the video, the Physical Therapist would periodically stop the video and discuss particular aspects of the transfer that the participant had difficulty performing during the baseline assessment. Participants were given a copy of the video to take home and paper-based instructions detailing the information presented during the education intervention. Study participants were asked to watch the video and review the written materials at home once every two weeks for a period of 12 weeks. Study participants were re-evaluated 12 weeks later using the same protocol.

Data Analysis

Data were analyzed using SPSS version 22 (SPSS, Inc., Chicago, IL). Descriptive statistics were utilized to evaluate demographic variables. To examine differences between TAI scores (ordinal data) pre and post exposure to the intervention, a generalized linear model was utilized. Significance was set a priori at $p = 0.05$. Due to the pilot nature of the study, no corrections were made for multiple comparisons.

Results:

SWMDU were an average of 58 years old and lived with MS for an average 17 years. The majority of the participants were affected by secondary progressive MS (44%). Nine SWMDU used a manual wheelchair, 6 a power wheelchair and 1 a scooter. No injuries were associated with the study intervention. Approximately 88% of the study participants reported that the transfer education was helpful. After exposure to the education program, TAI scores significantly improved. (Pre-Intervention: 6.1 ± 2.3 , Post-Intervention: 8.0 ± 2.3 , $p = 0.001$).

Discussion:

Our preliminary results indicate that after exposure to the education intervention, transfer quality significantly improved. Previous research has found that transfers are frequently associated with falls(Rice et al., 2015) and upper limb injuries(Gellman, Sie, & Waters, 1988). Therefore, significant improvements in transfer quality has good potential to positively influence fall frequency and the health of the upper limb. Improvements in the quality of transfer skills can also have an impact on functional mobility and may influence participation levels. Further testing is necessary to examine these concepts. The improvements in the quality of transfer

skills are similar to those found by Rice, et al (Rice et al., 2013) in an examination of full time wheelchair users living with Spinal Cord Injury who were exposed to a structured educational program during acute inpatient rehabilitation. Rice, et al however found the program to be more effective among participants who required assistance to transfer. On the contrary, the majority of the participants (80%) in the current study performed independent transfers and responded well to the transfer education.

Conclusion:

Such improvements are noteworthy as no structured educational interventions are available for SWMDU with MS. Improvements in transfer skills may help to prevent falls and upper limb injuries and improve community participation and quality of life. Further testing is necessary to examine the long-term impact of the intervention.

References:

1. Curtis, K. A., Roach, K. E., Applegate, E. B., Amar, T., Benbow, C. S., Genecco, T. D., & Gualano, J. (1995). Development of the Wheelchair User's Shoulder Pain Index (WUSPI). *Paraplegia*, 33(5), 290-293. doi:10.1038/sc.1995.65
2. Gagnon, D., Koontz, A., Mulroy, S., Nawoczenski, D., Butler-Forslund, E., Granstrom, A., . . . Boninger, M. (2009). Biomechanics of sitting pivot transfers among individuals with spinal cord injury: A review of the current knowledge. *Topics in Spinal Cord Injury Rehabilitation*.
3. Gellman, H., Sie, I., & Waters, R. L. (1988). Late complications of the weight-bearing upper extremity in the paraplegic patient. *Clin Orthop Relat Res*(233), 132-135.
4. Learmonth, Y. C., Motl, R. W., Sandroff, B. M., Pula, J. H., & Cadavid, D. (2013). Validation of patient determined disease steps (PDDS) scale scores in persons with multiple sclerosis. *BMC Neurol*, 13(1), 37. doi:10.1186/1471-2377-13-37
5. Nyland, J., Quigley, P., Huang, C., Lloyd, J., Harrow, J., & Nelson, A. (2000). Preserving transfer independence among individuals with spinal cord injury. *Spinal Cord*, 38(11), 649-657.
6. Rice, L. A., Ousley, C., & Sosnoff, J. J. (2015). A systematic review of risk factors associated with accidental falls, outcome measures and interventions to manage fall risk in non-ambulatory adults. *Disabil Rehabil*, 37(19), 1697-1705. doi:10.3109/09638288.2014.976718
7. Rice, L. A., Smith, I., Kelleher, A. R., Greenwald, K., Hoelmer, C., & Boninger, M. L. (2013). Impact of the clinical practice guideline for preservation of upper limb function on transfer skills of persons with acute spinal cord injury. *Arch Phys Med Rehabil*, 94(7), 1230-1246. doi:10.1016/j.apmr.2013.03.008
8. Tsai, C. Y., Rice, L. A., Hoelmer, C., Boninger, M. L., & Koontz, A. M. (2013). Basic psychometric properties of the transfer assessment instrument (version 3.0). *Arch Phys Med Rehabil*, 94(12), 2456-2464. doi:10.1016/j.apmr.2013.05.001
9. van Drongelen, S., van der Woude, L. H., Janssen, T. W., Angenot, E. L., Chadwick, E. K., & Veeger, D. H. (2005). Mechanical load on the upper extremity during wheelchair activities. *Arch.Phys.Med Rehabil.*, 86(6), 1214-1220.
- 10.

IC17: Early Vs. Late Intervention with Custom Molded Seating

Thomas R. Hetzel, PT, ATP
May Claire Hetzel, PT

Not only is custom molded seating an appropriate early intervention, it is frequently the key intervention that provides a seated environment which promotes optimal physiological, psychological and functional benefits. As we are the first generation of caregivers providing care to people with significant disabilities who have the potential to live long productive lives, we have a responsibility to provide effective seating and mobility interventions that will help prevent skin, postural, and functional deterioration over time. It is essential that we take a pro-active approach and provide early intervention to those with neuromuscular disabilities.

When providing seating for the pediatric population, the paramount objective must be optimal fit. A wheelchair seating system's mechanism for growth is only valid if that mechanism does not compromise efficacy over time. As primary growth in the pediatric population occurs distally in the long bones, the mechanism for growing a seating system should reflect this. A sliding mechanism of back support relative to seat for growth alters the contours and fit proximally in order to address growth distally. Planar seating systems are often selected for their ability to "grow" in this fashion. This can result in less than optimal fit at initial delivery and further compromise over time. A potentially more responsible seating intervention is a custom molded seating system that can be grown distally, and to provide and maintain optimal proximal stability, while adapting for the client's growth over time.

An able-bodied person uses asymmetrical postures at rest for stability and needs asymmetrical postures for stability, control, and power for function – this is a "normal" result of child development (Goyen, T., Lui, K., 2002). Pathological asymmetry occurs when stability for function and rest is sought in the absence of the ability to transition in and out of different postures. A person may get "stuck" in a certain posture due to abnormal tone, spasticity, reflexes, or as a consequence of postural habits or strategies that result in prolonged static destructive postures. Wolff's Law states that the body grows and remodels in response to the forces that are placed upon it (Wolff, 1986). Placing specific forces in specific directions to the body can help it remodel. Fulford and Brown (Fulford, G.E. Brown, J.K. 1976) state that when an individual spends many hours without moving easily and often into different positions, soft tissues shorten, ligaments stretch and gravity affects the person's body, so that slowly and gradually it becomes distorted. Eventually the body changes shape and no longer bounces back to where it started. Any person with movement impairment is at risk.

Hill and Goldsmith (Hill, S.; Goldsmith, J. 2010) state that the body is a mobile structure which is vulnerable to distortion, but also susceptible to restoration, if the correct biomechanical forces are applied. So, if people regularly spend most of a 24-hour period in a posture that does not

promote balanced postural correction, they may experience chronic postural deterioration, and biomechanical forces are at the root of these body shape distortions that complicate wheelchair seating for many people (Kittleson-Aldred, T., Russell, G., 2016).

The inability to move or be moved into different positions leads to a multitude of complications, which include further immobility, increased asymmetries, skin breakdown, as well as cardio-vascular, cardio-pulmonary and gastro-intestinal dysfunction. These secondary complications can ultimately result in premature death in this fragile population with complex healthcare needs. Fortunately, accurate seating and body orientation can harness the forces of gravity to promote restoration towards upright balanced postures and sitting stability. Planar support surfaces, even generically contoured seating, often lack the accuracy and intimacy of fit, and the ability to create precise body orientations (in all planes) to counter destructive postural tendencies. Custom molded seating may prove to be the best first intervention, rather than the avenue of last intervention.

Persson-Bunke, Måns et al. (Persson-Bunke, Hagglund, Lauge-Pederson, and Westbom, 2012) state that children with cerebral palsy have an increased risk of developing scoliosis. The reported prevalence varies between 15% and 80% depending on the client's age and the severity of the cerebral palsy. Scoliosis has been associated with problems in sitting, pressure injuries, cardiopulmonary and gastrointestinal dysfunction, and pain. It has also been shown to be associated with pelvic obliquity, windswept tendency, and hip dislocation. In children with cerebral palsy, a spinal brace may slow the rate of progression of the curve magnitude, but most curves with a Cobb angle exceeding 40 ° will progress, also in adulthood, if not treated surgically (Persson-Bunke, Hagglund, Lauge-Pederson, and Westbom, 2012). This speaks to the importance of early intervention to slow or prevent postural deterioration, thereby avoiding or delaying the need for spinal surgery. Effective custom molded seating can help prevent the progression of a scoliosis, or, at the very least, slow the deterioration, allowing a child to reach an age where they are nearly full grown, healthy, stronger and more capable of recovering successfully from a spinal fusion.

Should spinal fusion surgery eventually be indicated, it is essential to provide responsible post-surgical seating. A spinal fusion typically results in a reasonable degree of postural correction, but it does not necessarily resolve the intrinsic forces that led to the scoliosis in the first place. The abnormal forces acting upon the client's spine will likely continue to be present post-operatively. It is essential to provide optimal postural support and protection to prevent failure of, or complications from, the spinal fusion. Additionally, a spinal fusion typically results in a less mobile sitter, and thus creates an elevated pressure injury risk profile. When done correctly, custom molded seating can provide the intimate protection and application of forces to protect the fusion and support good skin health.

Custom molded seating has clear advantages for people who present with consistent and persistent destructive postural tendencies that cannot be controlled by lesser planar and generic contoured seating. Justification for any custom

seating must include objective information regarding the inability of lesser technologies to control those tendencies. In addition to an objective postural assessment, further assessment of functional skills relative to seating options should also be completed.

Unfortunately, custom molded seating is too frequently a last-ditch effort to seat individuals with rapidly deteriorating posture. When the intervention is delayed, non-reversible postural deterioration and its severe sequelae may have already occurred. Historically, custom molded seating was heavy, bulky, difficult to keep clean, unable to manage heat and moisture, and had no mechanism to adjust for growth and change over time. Now, with advanced design and materials influenced by orthotic and prosthetic science, options for custom molded seating are readily available that are low in profile, adjustable for growth and change, easy to sanitize and efficient at managing heat and moisture. By addressing the shortcomings of traditional design, these new designs make custom molded seating an appropriate choice for the growing and developing child.

Similarly, relative to growing and developing children, adults with significant disabilities may exhibit a similar propensity towards destructive postural tendencies, but often have an elevated risk for pressure injuries secondary to elevated buttock-seat cushion interface pressure (Brienza, Karg, Jo Geyer, Kelsey, & Trefler, 2001), and poor postural alignment (Defloor, T., Grypdonck, 1999). Traditional custom seating systems have limited application for this population for much of the same reasons as stated above, but with the additional risk associated with the seat's inability to be adjusted/adapted to change over time, especially when addressing weight loss and tissue atrophy. Thus, high risk users are often prescribed and fitted with immersion/envelopment style cushions. Though capable of reducing peak pressures, the improved skin performance may come with compromise of sitting stability. Incorporation of adjustable orthotic and prosthetic principles within seating has been shown to yield favorable performance in improved sitting stability and reduction of pressures at high risk bony prominences as compared to the commonly prescribed floatation style cushions (Crane, B., Winger, M., Call, 2016).

In summary, responsible custom molded seating can be extremely beneficial to the well-being and overall support of people with significant mobility impairment, regardless of risk for pressure injury. Well-designed custom molded seating incorporating orthotic and prosthetic principles is an early intervention option for the pediatric and adult populations that fail to experience optimal seating outcomes with simpler seating technologies. Early intervention is key for more meaningful and lasting outcomes. Fit should always be the primary goal, and growth should not hinder performance throughout the useful life of the product. The capability of precise fit, coupled with a biomechanically sound mechanism for growth, creates a no-compromise custom molded seating option for the pediatric population. The ability to effectively decrease sitting pressures at high risk anatomy, even with the potential for change over time, while simultaneously providing accurate stable support, makes orthotic and prosthetic based custom molded seating a viable option for the adult user as well.

References:

1. Brienza, D.M., Karg, P.E., Jo Geyer, M., Kelsey, S., Trefler, E. (2001) The Relationship Between Pressure Ulcer Incidence and Buttock-Seat Cushion Interface Pressure in At-Risk Elderly Wheelchair Users Archives of Physical Medicine and Rehabilitation, 82 pp. 529-533
2. Crane, B., Winger, M., Call, E. (2016) Orthotic-Style Off-Loading Wheelchair Seat Cushion Reduces Interface Pressure Under Ischial Tuberosities and Sacrococcygeal Regions Archives of Physical Medicine and Rehabilitation, 97, pp 1872 - 1879
3. Defloor, T., Grypdonck, M.H. (1999) Sitting Posture and Prevention of Pressure Ulcers Applied Nursing Research, 12 pp. 136-142
4. Fulford, G.E. Brown, J.K. (1976) Position as a cause of deformity in Cerebral Palsy Developmental Medicine and Child Neurology, Vol. 18, pp 305-314
5. Goyen, T., Lui, K. (2002) Longitudinal Motor Development of "Apparently Normal" High-Risk Infants at 18 Months, 3 and 5 Years Early Human Development, 70, pp 103-115
6. Hill, S.; Goldsmith, J. (2010) Biomechanics and Prevention of Body Shape Distortion. Tizard Learning Disability Review, 15 pp15-30
7. Kittleson-Aldred, T., Russell, G. (2016) The Link Between Lying and Sitting: Implications for practice Abstract for 2017 International Seating Symposium
8. Persson-Bunke, M. Hagglund, G., Lauge-Pederson, H., Westbom, L. (2012) Scoliosis in a Total Population of Children with Cerebral Palsy Spine, 37, pp 708-713
9. Wolff, Julius (1986) The Law of Bone Remodeling Berlin Heidelberg New York: Springer-Verlag, 1986

IC18: Updating Referral Sources on Medicare Wheelchair Requirements

Cathy Carver, PT, ATP/SMS

Laura Cohen, PhD, PT, ATP/SMS

Introduction

Medicare has identified physicians and non-physician practitioners (NPPs) (physician assistants, nurse practitioners, clinical nurse specialists) as responsible parties for initiating, ordering and documenting medical necessity for manual and power wheelchairs. Yet, physicians and NPPs often receive little education and training about these technologies and are often unfamiliar with Medicare DME policies (LCDs and policy articles) even more than 10 years after policy implementation. Education and training of referral sources can help both clinicians (PTs/OTs) and rehab technology practitioners (RTPs) to obtain appropriate documentation and paperwork the first time. This not only improves effectiveness and efficiency for both the clinician and the RTP but ensures that appropriate documentation is on file with the supplier in the event of an audit. Yet most importantly, appropriate medical documentation expedites the turnaround time for processing and provision of the wheeled mobility equipment to the patient.

Outcome Learning Objectives:

Upon completion of this session, attendees will be able to:

1. Describe target audience for Medicare Wheelchair Requirements knowledge dissemination activities
2. Articulate three methods for disseminating information to busy referral sources
3. Develop a knowledge dissemination plan for use in your organization

Issues

In the course of physician and NPPs daily practice it is a relatively uncommon occurrence to recommend or prescribe a wheelchair for a patient. Yet policy makers have identified physicians and NPPs as the responsible parties for prescribing wheelchairs and related technologies. With the rapid pace of change within the healthcare environment it is challenging for physicians and NPPs to keep pace with the policies related to their daily medical practice. It is even more challenging to keep pace with policies that represent only a small infrequent portion of their work- DME policies.

To compound the situation physician practices are required to utilize electronic health records (EHRs) that often can create barriers to documenting required elements to qualify a patient for a medically necessary wheelchair and related items.

Dissemination Methods

The Clinician Task Force (CTF) has developed educational materials designed for referral sources (physicians and NPPs) to keep pace with Medicare Wheelchair Policy Requirements. By design these materials were created to be utilized for synchronous training (in-person presentation or webinar) and/or asynchronous training (video and self- study).

The use of online educational materials can be integrated with self-directed continuing medical education (CME) to help foster a culture of lifelong learning. The flexibility of asynchronous online CME offers participants options of time and location to complete the training. Furthermore, online, open source materials encourages participant access when learning is most relevant – when searching for answers to questions that arise in clinical practice, instead of that which occurs at an arbitrary time designated for CME.

For dissemination activities the CTF has partnered with the Association of Academic Physiatrists (AAP) to host, publicize and distribute training materials. To incentivize participation and encourage learning AAP will provide Continuing Medical Education (CME) credits at little or no cost to physician and NPP participants upon successful completion of the training materials and the post training assessment.

Materials

The CTF has prepared a set of materials entitled Medicare Wheelchair Requirements: Update for Physicians/Non-Physician Providers. Materials include:

- 10 minute introductory power point presentation for use at Grand Rounds to announce web based training materials
- 60 minute asynchronous video with or without posttest assessment required for CME
- Reference Materials

Upon completion physician and NPPs shall be able to: 1) distinguish features of complex rehab technology (CRT) wheelchairs as compared to standard durable medical equipment (DME) wheelchairs, 2) describe the elements of the physician face to face examination and documentation requirements, 3) access resources for policy and advocacy, 4) improve beneficiary access to appropriate and necessary CRT and DME.

Conclusion

Participants are encouraged to utilize training materials and implement action steps at your own organizations to assist with information dissemination to referral sources. The provision of CME credit may encourage participation and ultimately improve compliance with Medicare Wheelchair policy requirements. In the long run the goal is to help physicians and NPPs improve their effectiveness and efficiency in documenting medical necessity to facilitate timely provision of appropriate medically necessary wheeled mobility equipment for patients.

Resources

1. Levinson, D. R. (2009). Medicare Power Wheelchair Claims Frequently Did Not Meet Documentation Requirements. Retrieved July 22, 2016, from <http://oig.hhs.gov/oei/reports/oei-04-07-00401.pdf>
2. Department of Health and Human Services. (2015). Power Mobility Devices: Documentation & Coverage Requirements. Retrieved July 22, 2016, from http://www.cms.gov/Outreach-and-Education/Medicare-Learning-Network-MLN/MLNProducts/downloads/pmd_DocCvg_FactSheet_ICN905063.pdf
3. Department of Health and Human Services. (2016). Evaluation and Management Services. Retrieved July 22, 2016, from <https://www.cms.gov/Outreach-and-Education/Medicare-Learning-Network-MLN/MLNProducts/Downloads/eval-mgmt-serv-guide-ICN006764.pdf>
4. Centers for Medicare & Medicaid Services. LCD for Manual Wheelchair Bases (L33788). (2015); Available from: https://www.cms.gov/medicare-coverage-database/details/lcd-details.aspx?LCDId=33788&ver=6&CoverageSelection=Both&ArticleType=All&PolicyType=Final&s=All&Keyword=wheelchair&KeywordLookUp=Title&KeywordSearchType=And&lcd_id=30009&lcd_version=25&show=all&bc=gAAAABAAIAAAAA%3d%3d&
5. Centers for Medicare & Medicaid Services. LCD for Power Mobility Devices (L33789). (2016); Available from: https://www.cms.gov/medicare-coverage-database/details/lcd-details.aspx?LCDId=33789&ver=11&CoverageSelection=Both&ArticleType=All&PolicyType=Final&s=All&Keyword=power+mobility&KeywordLookUp=Title&KeywordSearchType=And&lcd_id=30009&lcd_version=25&show=all&bc=gAAAABAAIAAAAA%3d%3d&
6. Centers for Medicare & Medicaid Services. Medicare Coverage Database. (2016); Available from: <http://www.cms.gov/mcd/search.asp?clickon=search>

Contact Information:

Cathy Carver, PT, ATP/SMS

Chair CTF Work Group Physician/NPP Training
Physical Therapist, UAB/Spain Rehabilitation Center
Birmingham, AL
ccarver@uabmc.edu

Laura Cohen PhD, PT, ATP/SMS

Executive Director, Clinician Task Force
Principal, Rehabilitation Technology Consultants, LLC
Arlington, VA
laura@rehabtechconsultants.com

IC19: Environmental and Mobile Device Access for Power Wheelchair Users

Nancy Shuster, EdS, MS, OTR, ATP

Today's society is highly dependent on mobile technology for work, school, and interpersonal competence for immediate access to viewing and responding to text messaging, email, and telephone communications. Industries have been transformed since mobile devices are a catalyst for changing the dynamics around how people interact, conduct commerce, and learn. These technologies are more important for individuals who are dependent on powered mobility due to limited volitional upper and lower extremity control. Accessible solutions are an important consideration since it is an essential differentiator for success and independence.

Persons with motor and sensory impairment often lack independent access to this technology. Although they may be able to utilize the technology once setup for them, some rely on other people to help them access the technology. If the individual is utilizing a power wheelchair, they can drive to the location of the technology, have the technology brought to them and setup for their access, or include it as part of their power wheelchair system. If the technology is not within ease of reach, it may be used less frequently or even abandoned and impede the person's success and competency in many areas of their life. Nonuse of the device may lead to decreases in functional abilities, loss of freedom and independence, and risk of injury or disease (Scherer, M. J., 2000). Phillips and Zhao (1993) stated that the most significant factor associated with technology abandonment is a failure to consider the user's opinions and preferences since it does not meet the person's needs or expectations. These findings suggest that technology-related services should emphasize consumer involvement to reduce device abandonment, promote consumer satisfaction and independence.

Since most evaluations for a wheeled mobility device are held outside the person's contextual environments, the evaluating team should include an inquiry of the person's typical activities to optimize their self-care, work, educational, and interpersonal independence. This will require a needs assessment prior to the mobility device evaluation to ensure that specific features are included in the comprehensive assessment for the power mobility system. Conceptually, a power mobility system can function as the "dashboard" for controlling mobility and environmental control of portable mobility devices, computers (Windows, Android and Macintosh), telephones (cellular), speech

generating devices, and environmental appliances. Control over these multiple devices can lead to significant control over their life and maximize the independence of the individual.

Needs Assessment: Preparatory Planning Saves Time and Improves Quality Outcomes

For the individual who is new at using a wheeled mobility device, it is difficult for them to conceptualize all of their functional and medical needs. It is important for the experienced wheelchair user to identify what is effective in their current wheelchair and what needs are not effectively being addressed. Although the evaluating team's focus is frequently on the medical aspects of the person's motor and/or sensory limitations, the individual and their significant stakeholders can ascertain what needs are not being met in the current wheelchair. It is incumbent upon the evaluating team to help the individual and his or her stakeholders identify their needs before the on-site evaluation. Information gathering pre-casing methods can include an emailed or web-based questionnaire, telephone interview, or an onsite meeting sent to the individual and/or their stakeholders.

Consequently, when the actual wheelchair evaluation occurs, the onsite evaluating team can be prepared to include these issues in the evaluation for the power wheeled mobility device. The development of a "wish list" prior to the onsite evaluation can help the team understand the person's desires for independence and functional goals, while also addressing their bodily, functional and physical needs. Although it may seem that these methods may encumber the busy evaluating team, this process helps the team make recommendations by: [1] promoting the individual's empowerment, "buying in," and involvement in the evaluation process, [2] the evaluating team's research of various technology options prior to the assessment, and [3] allowing technology options to be ready or available for assessment/presentation during the on-site evaluation. Ultimately, this planning saves time and promotes quality outcomes for a successful wheeled mobility system and decreases the duration to rescue less-than-optimal outcomes.

Current wheeled mobility devices

<u>Assistive Technology</u>	<u>Manufacturer and Model</u>	<u>Approximate Date of Purchase</u>	<u>Special Features</u> e.g. Molded Seating, proximity switches, manual or power tilt or recline, power seat elevator, power or manual legrests or platform, Alternative controls used; e.g., head array, switches; specialty handrims	<u>Location of Use</u> e.g. Home, School, work and/or Community	<u>Effectiveness</u> e.g., size, postural control, skin integrity, ability to use to optimal activities of daily living independence
Manual Wheelchair					
Powered Wheelchair					
Manual wheelchair with power assist device					
Manual Wheelchair					
Medical stroller					

Current assistive technology

Assistive Technology Device	Type and/or Manufacturer/Model and/or Platform/Operating system	Features e.g. screen enlargement, voice output, special switches, word prediction	Effectiveness of current strategies
Computer			
iPad or similar device			
Commonly used apps/software			
Manual Communication Board			
Augmentative Communication Device			
Vision Aids			
Amplification or Listening System/Aides			
Adapted classroom or home chair			
Ambulation Aids			
Stander			
Alternative Positioning Equipment			
Writing Aids			
Reading Aids			
Mobile telephone			
Control of environmental appliances/devices e.g. air conditioner, lights, door, television			
Alternative Positioning Equipment			
Hygiene equipment			
Lift for transfers			

What are the barriers impeding your [or the individual's] ability to complete expected tasks?

Task	Barrier
<i>Example 1:</i> unable to reposition for comfort and skin integrity <i>Example 2:</i> unable to use telephone to communicate <i>Example 3:</i> unable to access water bottle to address neurogenic bladder risks	<i>Example 1:</i> upper extremity weakness and lack motorized feature <i>Example 2:</i> lack ability to access mobile phone from power chair without asking others for help <i>Example 3:</i> unable to position or hold water bottle and reach mouth

**Are you [or is the individual] expected to transition to a new environment?
When? What demands will this pose?**

Transition	When	Demands

Given the above information, what are the functional areas of concern?

What do you (or the individual) need/want to be able to do that is currently difficult or impossible to accomplish independently or does not effectively address a medical condition?

What is your "Wish List?"

What questions or goals would you like the assistive technology evaluation/consultation to address?

Hardware Mounting Options

Once the needs assessment is completed for the actual device/technology and input method, the evaluating team determines how the device(s) will be mounted, based upon the person's functional needs. There are numerous commercial mounting devices available that require comprehensive evaluation based upon the device type and placement, mount placement, and desired or anticipated task independence. There are mounts that an individual can swing manually into place, require a care-provider to swing into place, and motorized mounts that can be controlled by use of a switch or integrated into the electronics of the power wheelchair. Ideally, the device and mounting should augment the individual's task independence for optimal visual pursuit and access.

Considerations for the evaluating team when choosing a mount design and placement include:

- Can the person independently move the mount into place and swing it out of the way in order to drive the power wheelchair?
- Can the individual manually swing the mount in/out of its place? How heavy is the device and is independence a realistic objective?
- If the person cannot manually swing the mount away independently, is it safe for the individual to control their powered wheelchair with the device mounted in place?
- Can a motorized mount allow the device to be swung away independently?
- What functional tasks need to be considered to allow variable movement of the device toward and away from the person at specific times; e.g., eating, drinking, hygiene tasks, specific tabletop tasks?
- Are there considerations to avoid bumping/harming the device or mount; e.g., transfers, doorways, transportation?

Based upon the person's needs, the team can research and contact companies who sell custom mounts to decide what device is optimal for the individual such as Daedalus, BlueSky Designs, Therafin, Stealth, Daedalus, Tobii-Dynavox, REHAdapt, CJT Enterprises, Prentke Romich, Falcon, and Motion Concepts. These mounts range from \$300.00 to over \$4000.00.

Customizing and Configuring Power Wheelchair Electronics for Mobile Access

Access to any device is obviously critical to the individual's ability to be independent. In an age when being connected to technology is important, something as simple as having access to a smart phone is vital to individual's daily communication as he/she uses a power wheelchair. When a team is working with an individual who has significant medical and functional needs, the need to independently access other technology from the power wheelchair should also be considered as part of the evaluation. Often, due to the person's limited motor skills, the same access methods or consistent movements used to drive the power wheelchair

must be utilized to access other technology such as computers, tablets or smart phones. The power wheelchair electronics may be utilized to control more than just the power wheelchair.

What technology is available in a power wheelchair to allow the individual to control the power wheelchair and other technology to enhance their functional independence? Power wheelchair manufacturers have technology to allow an individual to access smart phones, tablets, computers and communication devices through the power wheelchair electronics. Some manufacturers charge for these features and some embed these features with their higher level electronics. Bluetooth technology is typically utilized to access laptops, tablets, communication devices and smart phones, and allows the user to utilize the power wheelchair input device(s) to control one of the listed devices with wireless access. This may be performed through a Bluetooth mouse function built into the Smart phone, tablet or other technology. Or, if an Apple product is in use, the option of using a switch control feature can be considered as part of the Apple accessibility features.

Most Android and Windows OS devices, whether they are a tablet or a smart phone, have a built-in Bluetooth mouse function. This allows the user to use the Bluetooth mouse screen on their power wheelchair and connect their already paired smart phone or other device and use their power wheelchair input device to control the mouse on their Windows or Android device. The mouse on the device functions exactly like it would if they were using a computer mouse. For mouse clicks, the device will have a built-in dwell feature, or the manufacturer's electronics can offer the mouse click feature through a specific input command. This allows the individual to be independent utilizing their power wheelchair electronics to control the Windows or Android device.

Switch control on an Apple device works differently from the Windows and Android platforms. The Bluetooth on the device (iPhone or iPad) is paired with the wheelchair electronics they are using. The user then uses their input device on the power wheelchair to provide input commands to the scanning feature setup on the Apple device. This access method allows applications, onscreen keyboard use and making or answering phone calls to occur with a wireless Bluetooth connection. This access method may not be as fast as other methods yet provides a viable option for the consumer's independent access to the technology.

Conclusion

Accessible options are an important consideration for the person using the power wheelchair to access their mobile technology for optimal independence. The input method, mounting and whether the device is accessed through the power wheelchair electronics are decisions that require the entire evaluating team. The comprehensive assessment process should accentuate consumer involvement to reduce device abandonment, promote consumer satisfaction and independence.

References:

1. Baxter, S., Enderby, P., Evans, P., & Judge, S. (2012). Barriers and facilitators to the use of high technology augmentative and alternative communication devices: a systematic review and qualitative synthesis. *International Journal of Language & Communication Disorders*, 47(2), 115-129.
2. Johnson, J. M., Inglebret, E., Jones, C., & Ray, J. (2006). Perspectives of speech language pathologists regarding success versus abandonment of AAC. *Augmentative and Alternative Communication*, 22(2), 85-99.
3. Phillips, B., & Zhao, H. (1993). Predictors of assistive technology abandonment. *Journal of Assistive technology*, (5)1: 36-45.
4. Scherer, M. J. (2000, 3rd ed). *Living in the state of stuck: how assistive technology impacts the lives of people*

Contact Information:

Jay Doherty; Contact email: jdoherty@quantumrehab.com
Nancy Shuster, contact email: nshuster@aces.org

IC20: Creating a tool to define and evaluate competencies for training positioning and mobility specialists

Maureen Story, BSR (PT/OT)
Catherine Ellens, B.Sc OT,

It takes time and comprehensive training to become a proficient seating therapist or technician. At Sunny Hill Health Centre for Children we wanted a systematic way to train new therapists and technicians on our team, identifying present skills and targeting knowledge gaps. A tool was needed to measure knowledge and set learning goals based on self-evaluation. After exploring the tools that were available, we chose a tool that was developed in our organization and had been used in the nursing profession, the CAPE Tool. The CAPE Tool is defined as Competence Assessment, Planning and Evaluation Tool.

Competencies can be defined “as the integrated knowledge, skills, judgement and attributes that people need to perform a job effectively”¹.

In a healthcare setting, competencies outline the scope of the job and expectations of how the job is to be performed. Why use competency-based training tools?

A competency framework allows us to train incoming staff, who have a variety of skills and backgrounds, with consistent expectations. It provides them with a systematic way to assess their own skills and recognize their lack of knowledge and help direct them to vetted resources to gain new knowledge. It allows staff to understand the criteria by which they will be evaluated.

We reviewed other frameworks such as the RESNA Seating & Mobility Specialist Certification Exam Readiness Tool² and the Seating to Go³ credentialed competencies in developing the competencies for our CAPE tool.

The RESNA tool lists tasks and skills needed in performing seating and mobility services. The user is then asked to self-assess and rate their level of performance on the listed tasks.

Graphic 1 RESNA Certification Exam Readiness Tool

I. PERFORMANCE OF SEATING AND MOBILITY ASSESSMENT	No Experience	Participate or Assist	Under Supervision	Proficient
A. Determine the reason for referral, the problem, and the need				
B. Clarify the primary problems as the focus of the seating and mobility assessment				
C. Differentiate among the consumers' needs, desires, concerns, abilities, function, potential, limitations, risks and precautions				
D. Determine possible intervention and equipment and be able to explain in terms that the consumer can understand				
E. Explain to the consumer the components of the evaluation process (e.g., assessment of posture, skin, mobility, function as well as product trial, specifications, funding, fitting and training process)				
F. Assimilate relevant information from the medical record, interviews with consumer/caregiver, and other team members to identify needs and goals (e.g., ventilator/respiration needs)				
G. Review current seating and mobility devices used, discusses the pros and cons of these devices (e.g. what works well, what doesn't, why)				

The Seating to Go tool describes the competencies required to assess specific client needs and abilities and how these competencies are demonstrated.

Graphic 2 Seating To Go

Wheeled Mobility and Postural Management Level 1 - credential competencies

Description	Competencies Required	Demonstrated by
<p>Wheeled Mobility & Postural Management Level 1 Credential enables the assessor to assess people who:</p> <ol style="list-style-type: none"> Can self-propel, or use their foot to push (punt), a standard manual wheelchair and be safe and able to do essential daily tasks. Require a wheelchair or buggy for transport, behavioural/medical issues & may also require seating as for 4, 5 and 6. Can use a standard proportional joystick on a rear wheel drive or mid wheel drive powered wheelchair without a powerfoot 	<p>Knowledge:</p> <ul style="list-style-type: none"> Understands the biomechanics of pelvic positioning and the effect of position on function. Understands the principles of basic wheelchair configuration and prescription appropriate to area of practice. Can identify contributing factors / risks for development of pressure areas. Can identify contributing factors / risks for development of musculoskeletal deformity. Understands indicators for powered mobility and 	<p>Completion of the Seating To Go Learning and Development Programme for Wheeled Mobility and Postural Management Level 1 Credential. This ensures assessors can demonstrate an ability to:</p> <ul style="list-style-type: none"> Use knowledge gained to independently complete 3 physical assessments in supine and sitting as observed by supervising therapist or mentor. Use knowledge of the impact of wheelchair configuration on positioning and function to adjust and prescribe a standard manual or powered wheelchair with 3 people and can demonstrate this to

The CAPE Tool breaks down the required criteria for foundational and specialized skills. It has a rating scale to determine where the therapists/technician skills are at and highlights key resources that apply to the criteria, suggests recommended learning activities and has the ability to track when these skills have been met.

Level	Criteria	Need Learning & Practice	Knowledge able - But Need Practice	Competent	Expert/Help Others Learn	Key Resources Applies to all criteria (*See also supplementary resource list)	Recommended Learning Activities	Have I Done This? (Y)	Date Learning Goals Met
FSP	development of musculoskeletal deformities Describe the inter-relationships between posture, mobility and function including: Upper extremity function, Respiratory function, GI Function and Elimination Sensory function Cognition Communication Participation Environmental factors					E-learning Courses: Child Development and Rehabilitation , • Movement disorders • Pediatric feeding • Mod 1.2 • ICF Websites: Child Development and Rehabilitation : Seating and mobility Health conditions E for P Reviews • Wheelchair provision for children and adults with neuromuscular conditions • Positioning for children (GAPCS IV & V) Focus on hip health • Manual/Wheeled Mobility • Power Mobility • Power mobility for infants and preschoolers • Power mobility for school aged children • Hip Displacement and Dislocation • Pain in children with CP • Pathologic Fractures Internal Resources: V_dive_clinical	Mapping for Seating Complete training on X-Sensor pressure mapping equipment use. Review Equipment Websites. Compare power wheelchair features of manual wheelchairs and alternative positioning and mobility equipment.		
FSP	Describe contributing factors/ risks for development of pressure areas								
FSP	Articulate the principles of basic wheelchair configuration and prescription								
FSP	Describe indicators for powered mobility and programmable features for proportional joystick controls								
FSP	Seek out regulations and standards for medical devices and equipment including beds, wheelchairs, walkers/gait trainers								
FSP	Articulate any safety requirements or concerns related to use of								

Graphic 3

We found a number of benefits to developing and using the tool in our practice.

The benefits to the trainers are:

- The framework allows us to train incoming staff, who have a variety of skills and backgrounds, with consistent expectations
- We were forced to pull all of the resources into one document and to ensure that they were up to date and evidence-based
- We quickly realized where our gaps were in our resources
- We could easily refer to the tool and identify gaps in new staff learning and ensure that they had exposure to that area
- The tool guides the mentors to ensure consistent training for all new staff

The benefits to the new staff are:

- Provides them with a systematic way to assess their own skills
- Help them recognize their lack of knowledge
- Direct them to vetted resources to gain new knowledge
- Helps guide them into asking pertinent questions of their mentors
- Outlines the scope of the job
- Outlines what criteria new staff will be evaluated on
- Allows them to identify their strengths coming into the job
- The ability to create goals from their self-assessment
- Allows them to identify their progress
- As the CAPE tool is an online document, it is easy for new staff to find needed resources with the click of a button.

The limitations of the CAPE tool are:

- The tool is a lengthy document
- Only beneficial if people use it and have dedicated education time to utilize it
- Staff found it repetitive in areas with similar content
- The links need to be constantly checked to make sure they are working
- Staff said that they needed better instructions as to how to use it and track progress
- Due to the tool being online, resources that were in paper/book format were not as easily accessible and page numbers on topic not highlighted

The CAPE tool is only one way of training new staff. As we interviewed new staff in our centre who have used it, they found it useful in directing their learning in their new roles. We have had many staff start on our team at one time and it has allowed us to provide consistent and standardized training. It has also provided them with a systematic way of tracking their progress and highlight learning goals. Some have also found it beneficial as a basis for their performance reviews.

References

1. Mindtools. (1996-2016). Developing a Competency Framework. Retrieved from https://www.mindtools.com/pages/article/newISS_91.htm
2. RESNA. (2009). Seating & Mobility Specialist (SMS) Certification Exam Readiness Tool. Retrieved from http://www.resna.org/sites/default/files/dotAsset/SMS_Exam_Readiness_Tool_FINAL.pdf
3. Ministry of Health, New Zealand Government. (2016, March). Competency Framework: Wheeled Mobility and postural Management. Retrieved from http://www.disabilityfunding.co.nz/_data/assets/pdf_file/0006/54681/Competency-Framework-Wheeled-Mobility-and-Postural-Management-March-2016.pdf
4. Brownie, S., Bahnisch, M., Thomas, J. (2012). Competency-based Education Training & Competency-based Career Frameworks: Informing Australian health workforce development. Brisbane: University of Queensland Node of the Australian Health Workforce Institute in partnership with Health Workforce Australia.

IC21: Past, Present and Future of Tilt & Recline

K. Missy Ball, MT, PT, ATP

Stephanie Tanguay, OT/L, ATP

Greg Peek

In this session, past, present and possible future design of tilt-in-space and recline wheelchairs will be explored. Distinctions in tilt-in-space versus recline systems, as well as technical specifics in frame design and clinical application will be discussed. This presentation will walk you through the verified historical developments and inventions which have led us to the current art of power and manual systems used in the wheelchair industry, both recline and tilt. The reasoning and mechanics of these developments will be discussed. In exploring the current state of the art, a challenge and invitation for the next step will be given.

When discussing the clinical rationale and distinctions for recline, tilt or both the impact of changing a client's orientation in space needs to be considered. Arousal, skeletal alignment, soft tissue flexibility (ROM), skin integrity, reflex activation, tonal changes, compensatory pattern elicitation, functional access for activities or switches, cardiopulmonary status, ingestion/swallow, digestion/elimination, perceptual orientation, visual field, and bone integrity may be affected. Traumatic Brain injury clientele in the early stages of rehabilitation may have arousal issues, as well as limited head and trunk control. Arousal occurs best in positions closer to vertical. Determining the degree of tilt to assist with postural control without diminishing arousal is crucial to progress, but tricky. Tilt for effective pressure management has been documented in numerous research. In 2011, Giesbrecht, et al. in *Different Models of Dynamic Tilt in Manual Wheelchairs* measured interface pressure through pressure mapping at various degrees of tilt on 18 SCI with same seat cushion and model of TS chair used with seat to back angle fixed at 100°. The results stated at least 30° of tilt are needed to produce a reduction in pressure at IT's of clinical value, the greater the tilt angle the more reduction. Skeletal alignment, tone and reflexive activity can change with seat to back angle adjustments, particularly with neurologically involved clients. Therefore, it is critical to assess each client with regard to these options to avoid negative repercussions. Example, for a 2 year old client demonstrating an intermittent extensor pattern, increasing hip flexion (reducing seat to back angle) will reduce force generation, preventing hip extension and allow the client to possibly develop more functional movement strategies instead of a mass pattern of extension. However, if a client does not have potential for improvement in functional strategies and is using mass extension to improve inhalation (respiration), dynamic movement or pressure relief, then a dynamic back mounted on a central gravity axis tilt maybe appropriate providing the client momentary recline for better inhalation, while reseating the pelvis effectively after thrust. In the recline frame, skeletal alignment changes as seat to back angle opens, hence hip and possibly knee joint range needs to be adequate to handle this. If using the basic recline

design, postural control & positioning, switch access and skin integrity maybe challenged with this skeletal shift. So how did these wheelchair systems develop?

In 1869 Blunt and Smith patented the first wheelchair with full reclining back. It worked so well there were no significant design changes until 1986- 117 years later. In 1929, Knabusch and Shoemaker, furniture store owners, were granted a US patent "to provide a cushioned chair having a swinging back ...to prevent cushioned surface of back from dragging the clothes of the user..." - unknowingly addressing shear in the back. This chair design and company would later be called La-Z-Boy. Everest & Jennings designed and manufactured the first power wheelchair in 1956. In 1954 Rugg, an electrical engineer who suffered a spinal injury, and Bill Orr designed a reclining power wheelchair patented (1965) that was instrumental in the SCI rehabilitation program at Craig Hospital. Falcon Manufacturing built several of these chairs. Folio Products, started by Gary Sandritter, in the 1970's was also involved with recliners. In 1981, Greg Peek was asked to develop a recliner with a raised pivot point three inches above the standard E&J model to accommodate the High Profile RoHo cushion and move the seat actuator down to prevent contact with sling seat upholstery. Greg solved these issues and developed LaBac in 1983 with the specific purpose of building recliners.

Recline systems produce a change in seat to back angle with an angular and linear relationship change between seating components and the client. Recline systems provide a change in position by allowing the back to pivot rearward without a change in the orientation of the seat. Basic recline manual and power chairs use a pivot point that is level with the seat rail of the chair, which is not in alignment with the client's pivotal point. This promotes an increase tendency for downward migration of the client's center of mass on the seat, as well as the migration of the torso down the back. Adding a seat cushion compounds the problem by adding more distance between the person's pivot point and the frame's pivot point. Shear results as the back support moves against the person's skin. Shear is the parallel or tangential force between the user and the seating surface, caused by two forces acting in opposing direction. Shear deforms tissue and when present with perpendicular force can accentuate skin damage. In the mid 80's several power manufacturers were aware of the negative effects of shear and began implementing design changes. The incorporation of the raised pivot point for the back canes or displacement of the back support surface against the client either thru a manual sliding back mechanism or power sliding back helped to reduce shear. LaBac was one of the pioneers in these designs. In 1985, LaBac designed and patented a "wheelchair having adjustable backrest", defined as a sliding back which moved downward during recline capable of adjustment to client's needs. With this invention shear in a wheelchair back could be eliminated.

So what clinical rationale and ramifications are there for the use of recline. Modifications to the seat to back angle can affect cardiopulmonary function, skeletal alignment, postural control & function, manual reach, visual field, and transfer capability. Indications for a seat to back angle greater than 90° could be hip flexion limitations, respiratory compromise, skeletal deformity, comfort, fatigue, postural hypotension,

venous return insufficiency, tracheostomy care, pressure reliefs, urinary catheterization, or passive range of motion. Contraindications for recline could include limited range of motion at hip and knee, obligatory primitive reflexes or tonal changes, skin issues, and loss of functional posture, forward reach and vision.

The tilt-in-space design was first conceived by Hugh Barclay, an orthotist, working with physically challenged children. The first tilt-in-space wheelchair was invented in Kingston, Ontario Canada in the early 1980's. Tilt-in-space chairs have been utilized for more than 30 years as a means of shifting weight from the buttock to the back for pressure management. The tilt-in-space frame allows change in a client's orientation to gravity while maintaining the same seat to back angle and relationship between seating components to the client. Tilt-in-space chairs have evolved from a single posterior pivot point design, requiring a longer wheelbase for stability, to the center of mass or rotational design with improved stability and shorter base requirements. So what criteria determine the need for tilt?

When choosing tilt-in-space for a client several design features need to be considered including the plane in which the tilt occurs, the direction and degree of tilt, the location of tilt axis on the frame, single pivot vs rotational axis, and the need for variable or fixed tilt. The plane of tilt can occur in the sagittal, frontal or a combination of the two planes. The direction also can be specified within this plane of motion-sagittal (anterior or posterior tilt), frontal (lateral tilt left or right), or oblique (diagonal). Different variable tilt frames may allow from 30 to 60° of posterior tilt, and possibly 5 to 20° of anterior tilt. The placement of the tilt axis within the frame can be anterior, posterior, central or floating. Location of tilt axis on the frame may affect visual field, forward reach, access to wheel for propulsion, knee excursion and frame stability. Fixed tilt can be achieved in the frame design itself, or through adjustable hardware which attaches the seat and back to frame at a specific angle, or through vertical axle adjustment on a lightweight frame. Adjustable tilt can be incremental or infinite and is achieved within the frame design. So what clinical criteria dictate the use of specific characteristics of tilt?

Posterior tilt is often used for clientele with significant muscle weakness, limited postural control, limited ability to weight shift and manage pressure relief, feeding/swallow issues, progressive muscle disease or paralysis (SMA, MD, MS), or an acquired injury (TBI, SCI). It can redistribute weight off the buttock onto the posterior torso, reduce gravity's influence on skeletal malalignment, assist in maintaining an upright functional posture, aid feeding, allow pressure relief for client with extensor spasms or extensor thrust without exacerbating issue, aid caregiver in dependent transfers, and allow head clearance for adult transport in van. Anterior tilt can facilitate active hip and trunk extension to improve sitting as well as improve forward reach, when applied to the appropriate client. Most functional tasks occur in an anterior pelvic tilt position. In the article, *Functional Seating for School-Age Children with Cerebral Palsy* by Costigan and Light (April 2011), the authors explain the numerous benefits of this adjustment in the seat, including speech production, intelligibility, and feeding. Mac Neela (1987) and Nwaobi & Smith (1986) have shown an anterior tilt improves respiratory function of the school- aged child in vital capacity and forced expiratory volume for clients with spastic cerebral

palsy. Lateral or oblique tilt can help manage GE reflux & saliva, facilitate gastric emptying, accommodate severe fixed deformity, and aid with positioning and balance for a more complex client.

Tilt axis placement can be critical when posterior tilt is necessary. Several examples, such as an obese client, SCI client with extensor spasms, or a client with a sensory tactile or vestibular high threshold issue with heavy banging against the back canes can displace the client's mass posterior in the frame and potentially disrupt stability if the axis placement is located posterior on the seat rail. The rotational central axis maintains the client's center of mass within the center of the frame promoting stability even in full rearward tilt. This configuration produces a smaller footprint for greater accessibility and maneuverability for caregivers as well as transfers less weight to the casters when upright reducing energy to push the chair and less repair issues.

Combinations of tilt and recline are often used with power mobility for clients with SCI, ALS, MD, MS and cerebral palsy. The benefits of combined tilt and recline are better pressure relief, multiple postural adjustments to increase comfort, sitting tolerance and functional position for tasks, aid physiological systems, ease caregiver transfers, and manage ROM and spasticity. In 2001 Aiassaoui et al., concluded tilt & recline combined reduced pressure more than tilt in space alone. In 2010, *The Effects of Tilt and Recline on Skin Perfusion over the IT*, researchers measured skin perfusion in 11 SCI wheelchair users. Results showed at least 35° of tilt with 100° recline or 25° tilt with 120° recline were needed for significant increase in skin perfusion to occur at the IT area. Researchers, Ding, et al. monitored 11 users (18-70y.o.) with diagnoses of CP, SCI, MS, MD for 2 weeks in their natural environment and found small angles in tilt & recline were used intermittently throughout the day with adjustments made for comfort, postural stability, and pressure reduction.

As we can see, wheelchair frame design has evolved over many years, with amazing advances in this technology. Failure to recognize and understand some of these distinctions in tilt and recline design will produce outcomes less than ideal. Consumers need to be educated on all aspects of chair performance to ensure optimum benefits.

References

1. Giesbrecht, EM, Ethans, KD, Staley, D. (2011). Measuring the effect of incremental angles of wheelchair tilt on interface pressure among individuals with spinal cord injury. *Spinal Cord*, 49, 827-831.
2. Costigan, FA, Light J. (2011). Seating for school-age children with cerebral palsy: an evidence-based tutorial. *Lang speech Hear Serv Sch*, 42(2):223-236.
3. Jan, Y, Jones, M, Rabadi M, Foreman, R, Thiessen, A. (2010). Effect of Wheelchair Tilt & Recline on Skin Perfusion over Ischial Tuberosity in SCI. *Archives of Physical Medicine & Rehabilitation*, 91(11), 1758-1764.
4. Ding, Leister, Cooper, et al. (2008). Usage of tilt-in-space, recline and elevating legrests in seating in natural environment of wheelchair users. *Journal of Rehabilitation Research & Development*, 45(7), 973-983.
5. Jan Y., Liao F., Jones M., Rice L., & Tisdell T. (2013). Effect of Durations of Wheelchair Tilt-in-Space and Recline on Skin Perfusion over the Ischial Tuberosity in People with Spinal Cord Injury. *Archives of Physical Medicine & Rehabilitation*, 94(4), 667-672.
6. Yang T., Hutchinson S., Rice L., Watkin K., & Jan Y. (2013). Development of a Scalable Monitoring System for Wheelchair Tilt-in-Space Usage. *International Journal of Physical Medicine & Rehabilitation*, 1(4), 129. Retrieved from Doi:10.4172/jpmr.1000129
7. Dicianno, B., Lieberman, J., Schmeler, M., et al. (2015, February 23). RESNA Position Paper on The Application of Tilt, Recline, and Elevating Legrests for wheelchairs. Literature update. Approved by RESNA Board of Directors.
8. Sprigle, S., Maurer, C., & Sonenblum, S. (2010). Load Redistribution in Variable Position Wheelchairs in People with Spinal Cord Injury. *J Spinal Cord Medicine*, 33(1), 58-64.
9. Sonenblum, S., & Sprigle, S. (2011). Distinct Tilting Behaviors With Power Tilt-in-space Systems. *Disabil Rehabil Assist Technology*, 6(6), 526-535.
10. Cherng, R., Lin, H., Ju, Y., & Ho, C. (2009). Effect of seat surface inclination on postural stability & forward reaching efficiency in children with spastic cerebral palsy. *Res Dev Disabil*, 30(6), 1420-1427.
11. Sonenblum, S., & Sprigle, S. (2011). The Impact of tilting on blood flow and localized tissue loading. *Journal of Tissue Viability*, 20(1), 3-13.
12. Titus, L. C. (2013). How power tilt is used in daily life to manage sitting pressure: Perspectives of adults who use power tilt and therapists who prescribe this technology. University of Western Ontario Electronic Thesis and Dissertation Repository. Retrieved from <http://ir.lib.uwo.ca/etd/1321/>. Accessed January 16, 2014.
13. Chung, J., Evans, J., Lee, C., Roxborough, L., Harris, S., & Rabbani, Y. (2008). Effectiveness of adaptive seating on sitting posture and postural control in children with cerebral palsy. *Pediatric Physical Therapy Journal*, 20(4), 303-317.
14. Jan, Y., Liao, F., Jones, M. A., Rice, L. A., & Tisdell, T. (2013). Effect of Durations of Wheelchair Tilt-in-Space and Recline on Skin Perfusion Over the Ischial Tuberosity in People with Spinal Cord Injury. *Archives of Physical Medicine and Rehabilitation*, 94(4), 667-672. doi:10.1016/j.apmr.2012.11.019

IC22: A Pommel Does What?

Lauren Rosen, PT, MPT, MSMS, ATP/
SMS

Learning Objectives

- List three common inappropriate uses of positioning equipment on a wheelchair.
- State the best process for determining seating and positioning needs.
- List three changes to your practice to assure proper seating of clients.

People who use wheelchairs have individual needs to for seating and positioning to achieve the best outcomes. As there are a number of types of support that can be given to a person, frequently, well meaning therapists and suppliers select the wrong supports for a particular problem. This usually leads to further problems and more complex issues. One commonly seen misuse is prescribing abduction pommels to prevent sliding. These devices are made to keep a person's hips more neutrally positioned. When used to stop sliding, a patient's genital region takes a large amount of pressure, which is uncomfortable and can cause medical issues. In many cases, properly adjusted pelvic belts, seat to back angles, and better cushion choice can successfully prevent sliding without injury to the person,

In pediatrics, there are many pieces of positioning equipment added to wheelchairs as preventative measures. Laterals are universally placed on many chairs for children to prevent the development of scoliosis regardless of whether a child has good trunk control. Research does not support this yet clinicians and suppliers continue to apply this technology to most children.

This session will discuss common pediatric and adult seating and positioning issues and how to address them for the best outcomes. Case studies and research will be included to illustrate the points.

References

1. Babinec et al (2013). RESNA Position on the Application of Wheelchairs, Seating Systems, and Secondary Supports for Positioning vs Restraint. Approved by the RESNA Board of Directors: June 21, 2013
2. Persson-Bunke et al (2012). Scoliosis in a Total Population of Children With Cerebral Palsy. *Spine*; 37 : E708 – E713
3. Hsieh, C. C., Hu, M. H., Lee, S. D., & Wei, S. H. (2011). Exploration of Factors Related to Wheelchair Postural Improvement in Long-Term Care Residents After an Individualized Wheelchair Intervention. *Assistive Technology*, 23(1), 1-12.

IC23: A Lifespan Blueprint for DME: Cerebral Palsy

Jonathan M Greenwood, PT, MS,
c/NDT, CEIS, DPT, PCS

Summary:

Katz and Johnson (2013) describe the long-term needs of children with cerebral palsy defining one of keys to constructing successful lifecare plans is to be intimately familiar with the needs of this child with cerebral palsy. They expressed the need to determine the extent and sequelae of the child's impairments, estimate prognosis, determine need and finally identify the costs for the medical and rehabilitative services, equipment, supplies and services. The Durable Medical Equipment (DME) Blueprint is a means of summarizing the potential needs of a child throughout their lifespan to best prepare therapists, physicians and families to make educated decisions on equipment selection over time.

Because healthcare providers know the functional status of children with cerebral palsy stratified by GMFCS level and age (Novak et al, 2012), we can expect to make certain clinical recommendations and forecast certain equipment needs over the lifespan of children with cerebral palsy. Novak et al (2012) completed a cross-sectional study using a chart audit of 242 children with a diagnosis of cerebral palsy and reviewed associated impairments in assistive equipment prescribed within the child's medical record. The study revealed that gross motor functional classification system (GMFCS) levels predicted both the amount of equipment needs any associated costs.

Clinicians, physicians and families vary in their introduction of DME to support the growth, development and function of the child. This instructional course is a look at recommendations throughout transitions and over time by GMFCS level for children with cerebral palsy in order to best prepare for potential needs based on the expected development of the child. The presenter surveyed providers familiar with children having a diagnosis of cerebral palsy and familiar with GMFCS classification levels (Palisano et al, 2007) and asked when they would recommend DME to children classified by age and GMFCS Level.

We will describe the indications, timing and costs for using Durable Medical Equipment (DME) with children having a diagnosis of cerebral palsy. Identify when equipment is needed, when to introduce this equipment and how much this equipment costs over the lifespan for this population. This information is useful to providers and family's caring for children with complex needs. An Australia study by Bourke-Taylor et al. (2013) describe family self-reported survey outlining equipment needs, parental time and out-of-pocket expenses to support children with GMFCS levels 3 – 5 to participate in life activities. They conclude that children who require the most assistance in play and recreation, also have the highest equipment needs for sitting, standing, communication and adaptive toys and leisure items.

The overall cost analysis review as a means to prepare for upcoming changes in reimbursement structures and health care systems to analyze the costs associated with the care of patients with complex medical needs such as children with cerebral palsy. The discussion of value or cost is a relative discussion to that of alternative interventions and secondary complications to not intervening with use of equipment. One Example to be discussed in this presentation will compare the cost of a stander for a child with cerebral palsy to the alternative costs associated with therapies and medical interventions. Paleg et al (2013) conducted a systematic review for recommendations of dosing of pediatrics supported standing programs and found evidence to highlight the benefits of standing programs 5 days per week demonstrating a positive effect on bone mineral density, hip stability, range of motion of the lower extremities in improvement in spasticity management. We will look at the cost of implementing a standing program for children with cerebral palsy in the cost of not implementing a standing program for these children. There is both a physiological benefit and financial benefit to implementing a standing program regularly at home or school for children with Cerebral Palsy.

References:

1. Katz RT, Johnson CB. (2013), Life Care Planning for the Child with Cerebral Palsy. *Phys Med Rehabil Clin N Am*, (24)491 – 505.
2. Novak, I, Smithers-Sheedy, H, Morgan, C. (2012), Predicting equipment needs of children with cerebral palsy using the Gross Motor Functional Classification System: a cross –sectional study. *Disability and Rehabilitation: Assistive Technology*, (7:1) 30-36.
3. Palisano, R, Rosenbaum, P, Bartlett, D, Livingston, M (2007), Gross Motor Functional Classification System Expanded and Revised. *Dev Med Child Neurol* 1997 (39)214-223.
4. Bourke-Taylor, H, Cotter, C, Stephan, R (2013) Young Children with cerebral palsy: families self-reported equipment needs and out-of-pocket expenditure. *Child: Care, Health and development*, (40:5) 654-662.
5. Paleg, GS, Smith, BA, Glickman, LB (2013), Systematic Review and Evidence-Based Clinical Recommendations for Dosing of Pediatric Supported Standing Programs. *Pediatric Physical Therapy*, ((25) 232-247.

IC24: Advances in Upper Body Function, Here Come the Robots!

Chantal Bérubé, OT

In 2009, the Christopher & Dana Reeve Foundation unveiled staggering statistics [1] based on research into the prevalence of paralysis across the United States. The study found that 5,596,000 people in the United States (approximately 1.9% of the population) are living with paralysis. 16% of these individuals (about one million) have said that they are completely unable to move and cannot live without continuous help. It is also estimated that of the approximately 1.5 million people who are confined to electric wheelchairs in the United States, between 100,000 and 500,000 could benefit from a robotic arm based on the type and extent of their disability [2]. Robotic aids may play an important role in health care in the future. As health care costs increase, new approaches will have to be found to deliver more benefits for the health care dollar. Using adaptive tools such as robots to decrease severely disabled people's dependence on full-time health care attendants would lessen those costs [3,4]. Frappier [5] show, on average, 42% of the attendants and natural caregiver time could be saved if participants had a JACO arm. On average, attendants supply 3.19 hours of daily caregiving time (excluding travelling time) and thus the model forecasts that JACO could enable to save 1.33 hours, generating a mean annual savings of 12,095\$CA per user, according to the base-case scenario.

Also, a large number of user evaluations and studies [6,7,8] have shown the social and personal benefits of assistive robots including independence (of the user, as well as of spouse, and relatives, etc.), improved quality-of-life, increased self-esteem and increased participation in society.

Assistive Robots

The field of assistive robotics is less developed than industrial robotics [9]. However, the specifications for robots in these two application areas are very different. The differences arise from the involvement of the user in assistive applications. Assistive robots must operate more slowly and be more compliant to facilitate safe user interaction. Special attention must be paid to human-machine interfaces that have to be adapted for people with disabilities. Industrial robots are typically powerful and rigid to provide speed and accuracy. They operate autonomously and, typically for reasons of safety, no human interaction is permitted.

Rehabilitation is an activity which enables a person to reach an optimum mental, physical, and/or social functional level. Thus, rehabilitation or assistive robotics deal with brisk robotic technology to provide people with physical disabilities the tools to improve their functional level. They are designed for people with severe disabilities in order to help them gain independence in tasks of daily living by increasing the potential activity and by compensating the prehension motor incapacity.

The main goal of robotics in rehabilitation is to provide considerable opportunities to improve the quality of life for a person with a physical disability. The primary benefit of an assistive robot is that it reduces the need for a human attendant [10].

The objective of the robotic approach is in general to assist the user to function with a maximum of autonomy in the environment for which the system is intended and within the constraints imposed by other considerations. This may be interpreted in different ways, such as [11]:

- To be autonomous in the execution of certain tasks;
- To be autonomous at a specific working station;
- To be able to function in daily life with less human assistance, thereby reducing the cost for attendants;
- To be able to function for a number of hours without human attendance.

Development Concept

There are three main development concepts of robots in the assistive field [12]:

1. Workstation Robots (static robots that operate in a structured environment)
2. Mobile manipulators
3. Wheelchair-mounted robotic systems

1. Workstation Robots

Workstations were the first robots designed for people with disabilities in the '60s and they were coming from industrial robots [13]. Spartacus was really the first one. It was then followed by the MASTER-RAID (Robot to Assist the Integration of Disabled) and the DeVar (Desktop Vocational Assistant Robot). The purpose was to give disabled people more autonomy in their daily work. Basically, a workstation is made up of a desk and some shelves where a robotic manipulator is fixed. The robotic arm is programmed to get various objects, such as a telephone, book, etc. whose positions are accurately known.

Workstations can be highly effective in the workplace [14]. Various models of workstation manipulators were developed. One could expect a workstation to be highly tailored to do specific tasks very well, or be designed for a broad range of tasks which can be performed in a fixed area.

Unfortunately, desk-mounted robotic systems stem from being confined to one space. The versatility of the overall system within one set-up is limited by the range of the arm. Desk-mounted robots can be tailored to perform a narrow range of tasks exceedingly well, or designed to have a greater capacity in the performance of general activities. In either case, a desk-mounted or workstation robot or stationary assistive device confines the user to a single location within a room, building, etc. which limits the user from effective social interaction or from new task assignments [14].

Fixed workstation robots have the advantage of being less complex and less expensive. Having robots in a fixed position gives the possibility of structuring the environment in a way known to the system, thereby facilitating the use of preprogrammed motions to speed up the execution of certain tasks. The space available allocated to the working station also allows the use of more elaborate (more bulky) display systems for the user interface and to integrate other devices within the system. The features of fixed working stations seem in particular suited for vocational work stations, where speed is important and the number of tasks is limited [11].

A specific type of workstation is low-cost workstations dedicated to self-feeding tasks. They consist of a lightweight robotic arm mounted on a special plate that is either put on a table or mounted on a stand. Some examples are Handy-I, Neater Eater, My Spoon and Obi [15].

Unlike fixed workstations self-feeding robots are able to operate in an unstructured environment, but they are confined to a single task [16]. Utensils (forks, spoons) placed at the end of the arm just grab food on a plate specially designed and lead to the person's mouth. The user can eat well, without the help of a third person and at pace he/she decided.

2. Mobile Robots

A powered platform which carries a robotic manipulator may be referred to as a mobile manipulator [14]. The platform or base of the device is able to move about an environment freely. They may be designed to operate in the air, underwater, or on the ground whether they feature a manipulator or not.

Mobile robot systems navigate autonomously and perform tasks for the user. These systems are very useful for bed-bound users. Oldest mobile robot systems are WALKY (1995) [17], MoVAR (1988), KARES (1996) [18], and CARE-O-BOT (1998) [19] are examples of such system. These robots have several characteristic advantages such as the ability to move independently from the wheelchair, moving from one room to another to fetch and carry objects, and serving more than one person.

These commercially available mobile robots provide an around-the-clock watch over the user and can remind them of medication, appointments, provide critical information to emergency personnel in the event of an accident, alert the user to visitors or intruders, and become a communications link to family members and physicians for virtual check-ups [14].

3. Wheelchair-Mounted Robotic Systems

Another type of assistive robot is a wheelchair fixed with lightweight manipulators [16,20]. Those have a different philosophy of the products mentioned above. These systems are fixed on the wheelchair, the working area is thus limited to the proximity of the wheelchair. Their goal is to evolve into an unknown environment of the machine and can perform any task. It allows people with disabilities to feed themselves and to reach objects on the floor, on a table or above their head. They therefore enable a higher level of independence. Some of these systems are being marketed, and others are still at the prototype stage.

A wheelchair-mounted robotic arm was designed and built to meet the needs of mobility—impaired people with limitations of upper extremities, and to exceed the capabilities of current devices of this type. A wheelchair mounted robotic arm can enhance the manipulation capabilities of individuals with disabilities, and reduce dependence on human aides [21]. The most famous are Manus (also known as iArm) and JACO.

Wheelchair-mounted systems have the obvious advantage of being available to users wherever they go. But the increased size of the robot arm system and wheelchair combined may reduce the mobility of the wheelchair. Heavy constraints are imposed, however, by its combination with the wheelchair, in particular when it has to fit on different types of wheelchairs that were not designed with an additional manipulator in mind and where space is tight. In particular, the requirement that it should not increase the width of the wheelchair so much that it cannot pass through a door gives an absolute limit on available space. Other limitations imposed by the robots' attachment to the wheelchair follow from the requirement to make it easily removable from the wheelchair for transfers, for transportation, or simply when the user wishes to move about without the arm [11].

Indications for Use of Wheelchair-Mounted Robotic Arm

According to some studies, the number of people with disabilities in the United States who could benefit from using a wheelchair mounted robotic manipulator is estimated at most to be 150,000. This includes people with muscular dystrophy, spinal cord injury, spinal muscular atrophy, multiple sclerosis, amyotrophic lateral sclerosis, cerebral palsy, rheumatoid arthritis, post-polio syndrome, locked-in syndrome, and other severe motor paralysis [22]. Also, the number of people in the United States over age of sixty-five will double from 34.7 million to 69.4 million by 2030 [23]. As these people begin to show degenerative symptoms, needs of assistance in object manipulation will increase [24].

It is not hard to select appropriate users for those assistive robot, mainly for the wheelchair-mounted robotic arm. A major goal is that the assistive device meets a person's specific needs, is consistent with his or her skills, and accomplishes unique functions within the context of that person's daily life. This assistive technology system selection process emphasizes use of available function (human component) to accomplish what is desired (activity) in a given context (place, environment, people) [25]. Functional results require maximizing the skills of the person with a disability, which places human performance at the centre of our system.

It is recommended that user meet the following requirement in order to use a wheelchair-mounted robotic arm [36]:

- have very limited or non-existent arm and/or hand function;
- use and control an electric powered wheelchair;
- have sufficient learning skills to learn how to operate the arm;
- have sufficient concentration, attention and judgment to use the arm safely;
- have a strong will and determination to gain independence;

- have sufficient visual discrimination to distinctly perceive objects with arm reach;
- have no unresolved issues of self-harm or self-abuse;
- have no unresolved issues of violence toward caregivers.

Summary

In conclusion, it has been well proven that when wheelchair mounted, robotic technology is properly applied to the environment of appropriate people with disabilities, benefit is shown for the users of the technology, the families and or caregivers of those users, and potentially for the insurers and health systems charged with the care of those users. Assistive robotics is a rapidly growing sector. There are already studies in progress to create new products that are more effective, and less expensive. There are also studies concerning the improvement of assistive robots already available on the market. The next critical step is to have assistive robots reimbursed by private and public insurers and we will see most barriers for people with disabilities fall.

Bibliography

1. Christopher and Dana Reeve Foundation. (2008) One degree of separation: paralysis and spinal cord injury in the United States, available online [www.christopherreeve.org/site/c.ddJFKRNoFiG/b.5091685/k.58BD/One Degree of Separation.htm](http://www.christopherreeve.org/site/c.ddJFKRNoFiG/b.5091685/k.58BD/One-Degree-of-Separation.htm)
2. Johnson, C., Kocher, T., O'Donnell, C., Stevens, M., Weaver, A., Webb, J., ... Step II Machining & Manufacturing Class. (n.d.). Final Report on Robotic Manipulator Project (Rep.).
3. Awad, R E., & Engelhardt, K. G. (1984) Dissemination issues for medical robots. In RESNA Proceedings (pp. 102–104) Memphis, TN RESNA in Glass, K., & Hall, K. (1987). Occupational Therapists' Views About the Use of Robotic Aids for People With Disabilities. *American Journal of Occupational Therapy*, 41(11), 745–747. doi:10.5014/ajot.41.11.745.
4. Glass, K., & Hall, K. (1987). Occupational Therapists' Views About the Use of Robotic Aids for People With Disabilities. *American Journal of Occupational Therapy*, 41(11), 745–747. doi:10.5014/ajot.41.11.745
5. Frappier, J. (2011). Clinico-economic study of the JACO robotic arm for powered wheelchair users with upper-extremity disabilities—To justify reimbursement to third party payers (Rep.). Data 4 Actions.
6. Hammel, J., Hall, K., Lees, D., Leifer, L., Loos, M. V., Perakash, I., & Crigler, R. (1989, Summer). Clinical evaluation of a desktop robotic assistant. *Journal of Rehabilitation Research and Development*, 26(3), 1–16.
7. Stanger, C. A., Anglin, C., Harwin, W. S., & Romilly, D. P. (1994, December). Devices for assisting manipulation: A summary of user task priorities. *IEEE Transactions on Rehabilitation Engineering*, 2(4), 256–265. doi:10.1109/86.340872
8. Efring, H. (1999). The Usefulness of Robots for People with Physical Disabilities (Unpublished master's thesis, 1999). Lund University.
9. Garcia, E., Jimenez, M., Santos, P. D., & Armada, M. (2007). The evolution of robotics research. *IEEE Robotics & Automation Magazine*, 14(1), 90–103. doi:10.1109/mra.2007.339608
10. Santis, A. D., Gironimo, G. D., Marzano, A., Siciliano, B., & Tarallo, A. (2008). A Virtual-Reality-based evaluation environment for wheelchair-mounted manipulators. *Eurographics Italian Chapter Conference*, 1–8.
11. Rosier, J., Woerden, J. V., Kolk, L. V., Driessen, B., Kwee, H., Duimel, J., . . . Bruyn, P. (1991). Rehabilitation robotics: The MANUS concept. *Fifth International Conference on Advanced Robotics 'Robots in Unstructured Environments*. doi:10.1109/icar.1991.240560
12. Kawamura, K., & Iskarous, M. (1994, October). Trends in service robots for the disabled and the elderly. *Proceedings of IEEE/RSJ International Conference on Intelligent Robots and Systems (IROS'94)*, 1647–1654. doi:10.1109/iros.1994.407636
13. Dune, C., & Marchand, E. (2009). Localisation et caractérisation d'objets inconnus à partir d'informations visuelles vers une saisie intuitive pour les personnes en situation de handicap (Unpublished master's thesis). Université de Rennes 1.
14. Capille, J. W. (2010). Kinematic and experimental evaluation of commercial wheelchair-mounted robotic arms. University of South Florida. Graduate School Theses and Dissertations. Paper 3569. Retrieved from <http://scholarcommons.usf.edu/etd/3569/>
15. Obi | Robotic feeding device designed for home care. (n.d.). Retrieved November 04, 2016, from <https://meetobi.com/>
16. Biard, N. (2008). Robotique d'assistance et compensation des limitations de préhension — Implémentation d'une commande référencée vision sur le bras manipulateur Manus : Évaluation du projet AVISO (Unpublished master's thesis). Université René Descartes Paris 5.
17. Neveryd, H., & Bolmsjö, G. (1995). WALKY, an ultrasonic navigating mobile robot for the disabled. *Proceedings of the 2nd TIDE Congress* (pp. 366–370).
18. Bien, Z., Chung, M., Chang, P., Kwon, D., Kim, D., Han, J., . . . Lim, S. (2004). Integration of a Rehabilitation Robotic System (KARES II) with Human-Friendly Man-Machine Interaction Units. *Autonomous Robots*, 16(2), 165–191. doi:10.1023/b:auro.0000016864.12513.77
19. Care-O-bot I. (n.d.). Retrieved October 28, 2016, from <http://www.care-o-bot.de/en/care-o-bot-3/history/care-o-bot-i.html>
20. Dune, C., Leroux, C., & Marchand, E. (2007). Intuitive human interaction with an arm robot for severely handicapped people—A One Click Approach. 2007 IEEE 10th International Conference on Rehabilitation Robotics. doi:10.1109/icorr.2007.4428484
21. Alqasemi, R., Edwards, K., & Dubey, R. (2006). Design, Construction and Control of a 7 DoF Wheelchair-Mounted Robotic Arm. 2006 IEEE/RSJ International Conference on Intelligent Robots and Systems. doi:10.1109/iros.2006.282573
22. Laffont, I., Biard, N., Chalubert, G., Delahoche, L., Marhic, B., Boyer, F. C., & Leroux, C. (2009, October). Evaluation of a graphic interface to control a robotic grasping arm: A multicenter study. *Arch Phys Med Rehabil*, 90, 1740–1748. doi:10.1016/j.apmr.2009.05.009
23. Haigh, K. Z., & Yanco, H. A. (2002). Automation as caregiver: A survey of issues and technologies. *AAAI 02 Workshop "Automation as Caregiver"* (pp. 39–53).

-
24. Chung, C.-S., & Cooper, R. a. (2011). Literature Review of Wheelchair-Mounted Robotic Manipulation: User Interface and End-user Evaluation. RESNA Annual Conference. Retrieved from <http://web.resna.org/conference/proceedings/2012/PDFs/StudentScientific/Robotics/LITERATUREREVIEWOFWHEELCHAIR-MOUNTEDROBOTICMANIPULATION-USERINTERFACEANDEND-USEREVALUATION.pdf>
 25. Cook, A. M., & Hussey, S. M. (2002). Chapter 2: Framework for Assistive Technologies. In Assistive technologies: Principles and practice (3rd ed.).
 26. Chiasson, K. (2008). Analyse de l'interface de contrôle d'un robot manipulateur intégré à un fauteuil roulant motorisé (Unpublished master's thesis). Université de Montréal.

PS3.1: Beyond Mobility: Above Knee Amputee Case Study

Michael Bender, OTR/L, ATP/SMS,
CDRS

Carla Walker, OTD, OTR/L, ATP

The following case example illustrates the complexity and need for a collaborative, comprehensive process. Donnie was referred to Washington University's Seating and Mobility Clinic and Therapeutic Specialties by his vocational rehabilitation (VR) counselor for a mobility evaluation with the goal of returning to work. Donnie, a 48-year-old, 6'5" 400-pound man, acquired a left, above-the-knee amputation 7 months prior because of complications from diabetes. He was also recently hospitalized for a posterior residual limb wound with precautions restricting his ability to wear his prosthetic limb for 4 weeks and received services from a team of professionals including an MD, PT, PTA, and OTAs. Additional medical history included peripheral neuropathy in the right lower extremity, bilateral carpal tunnel, left shoulder pain with suspected rotator cuff tear, skin wounds to bilateral buttocks, and depression.

The occupational therapist and equipment supplier, both certified ATPs, performed the initial evaluation in the home. Donnie's home lacked an accessible ramp, preventing him from exiting his house in his manual wheelchair. The width of his wheelchair and home layout also prevented him from accessing his hallway and bedroom, affecting self-care and sleep. Several intrinsic and extrinsic factors were considered throughout the process, including Donnie's physical size, home accessibility, and transportation options. Because of his history of wounds, Donnie could not rely on consistent use of his prosthetic; wheeled mobility needed to be a viable means of functional mobility in the home and community for him to exit his home and seek employment. Perhaps the most pressing factor was accommodating Donnie's psychosocial challenges, which limited his ability to problem-solve and manage his depression.

Using a comprehensive team approach including Donnie, the community occupational therapist, equipment supplier, VR counselor, prosthetist, contractor, potential employer, physician and inpatient therapists (PT/OT, PTA/OTA) resulted in multiple solutions. To improve home accessibility and community reintegration for employment, the following solutions were determined: (1) home modifications including a ramp to his front door, reconstructed interior to widen the hallway and improve bedroom and bathroom maneuverability, and removal of carpet; (2) transfer poles installed in the bedroom and living room to assist with transfers; (3) acquisition of a shower prosthesis and shower bench; (4) fitting of a new manual wheelchair, to be used within the new home layout; (5) the VR counselor connected Donnie with an employer in Donnie's area of expertise who would accommodate his mobility and health needs; and (6) fitting

of a new power wheelchair to be used within the workplace for long-distance mobility, residual limb support, and pressure relief. Outcome measures used to monitor Donnie's performance and satisfaction included the Functional Mobility Assessment (Kumar et al., 2013), the Psychosocial Impact of Devices Scale (Jutai & Day, 2002), and the PROMIS measure, Psychosocial Illness Impact-Positive (PROMIS, 2015).

This comprehensive plan was the result of numerous visits among multiple team members and Donnie, who continues to work with the team to meet his mobility and participation needs. Consistent communication, support, information, and understanding among all team members were critical throughout this case. Despite periodic hospitalizations for ongoing residual limb wounds and infections, Donnie has managed to maintain his employment and is working toward pulling himself out of bankruptcy to allow him to purchase a van, which will allow him to use his power wheelchair in the community. He continues to struggle with psychosocial challenges such as a lack of friend or family support and has not agreed to a plan for addressing his depression, despite referrals. This case illustrates how crucial professional and funding supports can be in keeping someone engaged in their community, but that psychosocial factors can often continue to challenge clients even with the right equipment. Without the professional support and equipment provided, Donnie would still be stuck in his home; at risk for losing his vehicle and home and likely at risk for further complications of depression.

References:

1. Jutai, J. & Day, H. (2002). Psychosocial Impact of Assistive Devices Scale (PIADS). *Technology and Disability*, 14(3), 107-111.
2. Kumar, A., Schmeler, M. R., Karmarker, A. M., Collins, D. M., Cooper, R., & Cooper, R. A. (2013). Test-retest reliability of the functional mobility assessment (FMA): A pilot study. *Disability and Rehabilitation: Assistive Technology*, 8(3), 213-219.
3. PROMIS. (2015, July 8). Psychosocial Illness Impact-Positive. Retrieved from: <https://www.assessmentcenter.net/documents/PROMIS%20Psychosocial%20Illness%20Impact%20Positive%20Scoring%20Manual.pdf>

PS3.2: Advocating Necessity for Bluetooth Power Mobility Integration

Raheleh G. Tschoepe, MS, OT/L
Randy Pesich, ATP

Occupational and physical therapists and assistive technology (AT) professionals collaborate to assess limitations in body structures and functions and barriers in the environment and context that prohibit participation in meaningful and necessary participation. We also evaluate the resources and supports that facilitate function and with this combined information, determine AT options that facilitate participation and quality of life. During this process of working with the client and their caregivers, clinicians are ethically bound to provide information on all available AT options. During this process, we engage the client and their caregiver in investigating various tiers of options for acquiring the recommended equipment – primary and secondary health insurance benefits, fundraising, non-profit organization grants, loan closets, paying out of pocket, etc.

Our case presentation describes the process between a client, Nancy, with advanced Multiple Sclerosis (MS), her husband; an outpatient home-based OT, a manufacturer representative (ATP), a DME supplier (ATP), and physiatrist. The client had been known to this OT over a period of 6 years and in this time, she progressed from independent manual wheelchair use to full dependence on a power wheelchair with chin control and power seat functions. Nancy and her husband live in an urban North Carolina city close to downtown with access to public transportation. Nancy's husband worked full-time outside of the home. They had one hired caregiver who assisted Nancy with all of her activities of daily living (ADLs) 20 hours a week. Even in the advanced stages of MS, Nancy relied on her own ability to independently move about within and outside of her home. While the Permobil C500 VS power wheelchair she drove provided her with independent mobility and positioning options, Nancy had lost the ability to engage in leisure activities meaningful to her. She admitted that this was taking a toll on her emotional and mental health, causing her to feel "trapped." Nancy's goal and reason for referral to occupational therapy: identify AT to facilitate participation and independence in meaningful activity.

The OT evaluation revealed that Nancy had no volitional motor control and impaired sensation below the C4 spinal level, struggled with involuntary flexion and extension spasms, and fluctuating respiratory capacity and vocal quality. The first low-tech option she tried with OT included a mouth stick to help her turn the pages in a book. Nancy immediately ruled this out, as she did not have the strength or endurance to use the mouth stick fluently and effectively. Voice-activated dictation was not an effective option due to Nancy's lack of breath support, endurance and inconsistent vocal quality. OT then introduced the option of accessing Nancy's iPad through her C500 chin-controlled joystick. The vessel for

connecting her iPad through her power wheelchair was the Permobil iDevice. The iDevice used Bluetooth interfacing to integrate her power wheelchair and iPad technology. With this critical pairing, Nancy could now independently email family, friends and healthcare providers; read; access news and research desired topics; control aspects of her physical environment; and engage in her social environment. Her ability to do all of this through technology that closed the significant gap between capacity and function, provided her the ability to communicate, promoted safety, and improved her psychosocial wellbeing.

The OT and ATP began the work of improving Nancy's fluency accessing applications on her iPad through her chin-controlled joystick with a series of switches and switch combinations. As she increased in speed and accuracy, OT worked with her to apply these switch combinations to an increased number of applications. Access to her iPad opened up Nancy's world and she eventually became comfortable working with her husband to investigate and practice additional applications with the iDevice. It was clear that this piece of AT was Nancy's portal to independent IADL participation and health – functionally and medically necessary.

The OT, ATP, equipment supplier, and Nancy's physiatrist worked for nearly 18 months through a series of appeals requesting Medicare funding. Included in the letters of medical necessity for this AT was a video demonstrating Nancy's use of the iDevice where she also verbalized the extent to which her independence impacted her mental and emotional health. Medicare ultimately denied the funding request because the iDevice did not meet criteria for medically necessary durable medical equipment (DME).

This is a poignant example of funding too often driving decisions, overriding clinical reasoning, client need, and best practice. It demonstrates how AT returned independence, voice, and control to a client in the advanced stages of a neuroprogressive disease yet did not fit the inclusion criteria for medical necessity. It is evidence of the manner in which current policy conflicts with best practice and must be persistently challenged so policy makers are educated about the impact of their statutes. It reflects how our industry has an ethical and professional responsibility to demonstrate value in AT services and to empower clients to express the value of these products and services to insurance providers and policy makers. As AT solutions advance, funding must stay relevant and rehabilitation clinicians and industry providers must invest the resources to work parallel, advocating with clients benefiting from these solutions. The AT field must steadfastly research, develop, and prescribe the most effective solution for clients' needs based on best practice and not confine our clinical recommendations, scholarship, and pedagogy due to policy.

PS3.3: Outcomes in a Community-Based Wheelchair Seating Clinic

Sue Tucker, OTD, OTRL, ATP

Kerri A. Morgan, PhD, OTR/L, ATP

Carla Walker, OTD, OTR/L, ATP

David B. Gray, PhD

Purpose:

This presentation will focus on practices used by a community-based wheelchair seating clinic to pilot test a self-report assessment battery to collect outcomes related to provision of new mobility devices. The purpose of this project was to pilot test the use of an assessment battery that included the Functional Mobility Assessment (FMA; Kumar, Schmeler, and Karmarkar, 2013) and the Quebec User Evaluation of Satisfaction with Assistive Technology (QUEST; Demers, Weiss-Lambrou, and Ska, 1996) for tracking short- and long-term outcomes.

Background:

Limited research exists regarding the benefits of seating and mobility interventions in a clinic using a team-based approach of client, clinician (occupational therapist), physician, equipment supplier, and other significant persons (e.g., caregivers and family members; Chaves et al., 2004). Previous research on the outcomes of seating and mobility interventions typically have examined one component of outcomes. For example, several studies have examined only the capacity of wheeled mobility device users to perform certain skills (Best, Kirby, Smith and Macleod, 2006; Kirby, Swuste, Dupuis, MacLeod, and Monroe, 2002; MacPhee et al., 2004; Schein et al., 2011). Other studies examined user satisfaction with their mobility devices (Samuelsson and Wressle, 2008; Wressle and Samuelsson, 2004). The influence of new wheelchairs on user self-reported functioning has also been studied (Schein, Schmeler, Holm, Saptono, and Brienza, 2010). A limited number of studies have examined more than one component of seating and mobility outcomes after the acquisition of a new wheelchair, but none of these studies examined short- and long-term outcomes. Tolerico and colleagues (2007) conducted a study examining activity levels of manual wheelchair users and wheelchair users' satisfaction with their current devices, as well as some self-report questions on function with their wheelchairs. Chan and Chan (2007) performed a study on participation, user satisfaction with mobility device, and quality of life. Brandt, Kreiner, and Iwarsson (2010) conducted a study on participation and user satisfaction in which power wheelchair users evaluated their current wheelchairs.

Chaves and colleagues (2004) have recommended that studies be conducted to investigate the impact of seating

interventions and participation based on their findings that wheelchairs influence the participation of persons with spinal cord injury. Research related to wheeled mobility device evaluation, selection, and fit is important to provide evidence for skilled services provided by health professionals working with wheeled mobility device users (Mortenson et al., 2008; Sprigle et al., 2007). Outcome measures may provide information related to the impact of the device in meeting the needs of the person so that the person can be safe, comfortable, supported, and have mobility to be able to participate in meaningful activities.

Design:

A repeated measures within-subject design was used.

Measures: The FMA is an outcomes measure designed to gather information about a person's self-reported satisfaction with performing mobility-related functional tasks. The FMA is a 10-item survey in which a person rates their agreement with 10 statements related to the extent to which their current means of mobility allows them to perform different functional tasks on a six-point scale. The scale ranges from "completely agree" to "completely disagree." The QUEST is a 10-question survey designed to measure user satisfaction with assistive technology devices (Demers, Weiss-Lambrou, and Ska, 1996). The user rates his or her satisfaction with the device and related services on a five-point scale where a score of 1 corresponds to "not satisfied at all," and 5 corresponds with "very satisfied."

Participants: The target population for this outcome assessment battery was individuals who came to the Washington University Occupational Therapy Seating and Mobility Clinic in St. Louis, Missouri, to be evaluated for new wheelchairs and seating systems.

The inclusion criteria for the study were: (1) age 18 or older, (2) difficulty ambulating or non-ambulatory, (3) referred for new wheelchair evaluation, (4) able to answer a self-report survey, and (5) able to provide informed consent.

Thirty-nine participants were recruited for the study. Informed consent was obtained from participants. Data were not collected at each time point for all participants due to a variety of factors; some participants did not return our calls for the follow-up surveys, some participants were not able to get funding for the recommended mobility devices, and we were not able to make contact with some participants within study-specific time points. Only 18 of the 39 participants completed surveys at all three time points.

Methods:

Participants completed the first survey at an initial evaluation visit (T1), then completed a short-term survey three to nine weeks after receiving a new mobility device (T2) and a long-term survey 10 to 16 weeks after receiving the device (T3). Repeated measures analysis of variance (ANOVA) and paired t-tests were used to determine significant differences.

Analytical Methods: A repeated measures ANOVA was used to determine whether there were significant differences in total FMA scores between T1, T2, and T3 ($p < 0.05$). Paired t-tests were used to determine significant differences in QUEST item scores between T1, T2, and T3 ($p < 0.05$).

Results: Significant changes in total FMA scores were found from initial survey (T1) to short-term follow-up (T2; $N = 18$, means: pre 46.0, post 53.7, $p < 0.01$) and from T1 to long-term follow-up (T3; $N = 18$, means: pre 46.8, post 54.2, $p < 0.01$). Significant differences were found in 10 of 12 QUEST mean item scores from T1 to T2 ($p < 0.05$) and 8 of 12 QUEST mean item scores from T1 to T3 ($p < 0.05$). QUEST items that showed improved scores from T1 to T2 included weight of device, ease of adjusting, device safety and security, durability, ease of use, comfort, device effectiveness, repairs and servicing, quality of professional services, and follow-up services. QUEST items that showed improved scores from T1 to T3 included dimensions, weight of device, device safety and security, durability, comfort, device effectiveness, repairs and servicing, and follow-up services.

Discussion:

This pilot project identified significant positive changes in satisfaction and functional mobility associated with the provision of new mobility devices in a community-based seating and mobility clinic.

Kenny and Gowran (2014) have suggested that no single outcome measure specific to seating and mobility is able to gather all of the information necessary to evaluate the multiple factors that contribute to outcomes in seating and mobility clinics. Multiple outcome measures were used in this pilot study to address this issue. Using a variety of outcome measures as part of an assessment battery may allow a more in-depth, comprehensive evaluation of multiple influences on wheeled mobility device interventions. Regular use of outcome measures in seating and mobility clinics is a relatively new concept, but with the increasing emphasis on evidence-based practice, incorporating use of outcome measures to evaluate wheeled mobility interventions is key to showing the effectiveness of these interventions. Outcome measures are also helpful for wheeled mobility device users to evaluate how well devices are meeting their needs.

This study had several limitations including use of a heterogeneous convenience sample and a small sample size, which limits generalizability of the study. Future studies should include a larger sample size and should include participants being evaluated for scooters to allow for a more comprehensive analysis that is inclusive of all wheeled mobility device interventions rather than just power and manual wheelchairs. Additionally, studies that examine outcomes in a variety of seating and mobility clinic settings, including hospital and community, would be helpful for identifying factors across settings that promote better outcomes for people needing new mobility devices. The findings from this study are clinically relevant because they may assist providers in understanding the impact of mobility devices on the lives of the people using them and may assist providers with justification for mobility devices.

References

1. Best, K. L., Kirby, R. L., Smith, C., & Macleod, D. A. (2006). Comparison between performance with a pushrim-activated power-assisted wheelchair and a manual wheelchair on the Wheelchair Skills Test. *Disability and Rehabilitation*, 28(4), 213-220.
2. Brandt, Å., Kreiner, S., & Iwarsson, S. (2010). Mobility-related participation and user satisfaction: construct validity in the context of powered wheelchair use. *Disability and Rehabilitation: Assistive Technology*, 5(5), 305-313.
3. Chan, S. C., & Chan, A. P. (2007). User satisfaction, community participation and quality of life among Chinese wheelchair users with spinal cord injury: a preliminary study. *Occupational Therapy International*, 14(3), 123-143.
4. Chaves, E. S., Boninger, M. L., Cooper, R., Fitzgerald, S. G., Gray, D. B., & Cooper, R. A. (2004). Assessing the influence of wheelchair technology on perception of participation in spinal cord injury. *Archives of Physical Medicine and Rehabilitation*, 85(11), 1854-1858.
5. Demers, L., Weiss-Lambrou, R., & Ska, B. (1996). Development of the Quebec user evaluation of satisfaction with assistive technology (QUEST). *Assistive Technology*, 8(1), 3-13.
6. Kenny, S., & Gowran, R. J. (2014). Outcome measures for wheelchair and seating provision: a critical appraisal. *British Journal of Occupational Therapy*, 77(2), 67-77. doi: 10.4276/030802214x13916969447119
7. Kirby, R. L., Dupuis, D. J., MacPhee, A. H., Coolen, A. L., Smith, C., Best, K. L., . . . Bonaparte, J. P. (2004). The wheelchair skills test (version 2.4): measurement properties. *Archives of Physical Medicine and Rehabilitation*, 85(5), 794-804. doi: http://dx.doi.org/10.1016/j.apmr.2003.07.007
8. Kumar, A., Schmeler, M. R., Karmarkar, A. M., et al. (2013). Test-retest reliability of the functional mobility assessment (FMA): a pilot study. *Disability and Rehabilitation: Assistive Technology*, 8, 213-219.
9. Mortenson, W. B., Miller, W. C., & Auger, C. (2008). Issues for the selection of wheelchair-specific activity and participation outcome measures: a review. *Archives of Physical Medicine and Rehabilitation*, 89(6), 1177-1186.
10. Samuelsson, K., & Wressle, E. (2008). User satisfaction with mobility assistive devices: an important element in the rehabilitation process. *Disability and Rehabilitation*, 30(7), 551-558.
11. Schein, R. M., Schmeler, M. R., Holm, M. B., Saptano, A., & Brienza, D. M. (2010). Telerehabilitation wheeled mobility and seating assessments compared with in person. *Archives of Physical Medicine and Rehabilitation*, 91(6), 874-878. doi:10.1016/j.apmr.2010.01.017
12. Schein, R. M., Schmeler, M. R., Holm, M. B., Pramuka, M., Saptano, A., & Brienza, D. M. (2011). Telerehabilitation assessment using the Functioning Everyday with a Wheelchair-Capacity instrument. *Journal of Rehabilitation Research and Development*, 48(2), 115-124.
13. Sprigle, S., Cohen, L., & Davis, K. (2007). Establishing seating and wheeled mobility research priorities. *Disability & Rehabilitation: Assistive Technology*, 2(3), 169-172.
14. Tolerico, M. L., Ding, D., Cooper, R. A., Spaeth, D. M., Fitzgerald, S. G., Cooper, R., . . . & Boninger, M. L. (2007). Assessing mobility characteristics and activity levels of manual wheelchair users. *Journal of Rehabilitation Research and Development*, 44(4), 561.

PS3.4: Motor Learning Approach for Training Manual Wheelchair Users

Sue Tucker, OTD, OTRL, ATP

Kerri A. Morgan PhD, OTR/L, ATP

Joseph W. Klaesner, PhD

Jack R. Engsborg, PhD

Purpose:

Developing evidence-based approaches to teaching wheelchair skills and proper propulsion for people with SCI is important to successful rehabilitation for everyday wheelchair use. The purpose of this project was to pilot test a manual wheelchair training program based on motor learning and repetition-based training for new manual wheelchair users with a spinal cord injury (SCI). We hypothesized that, after participants received the wheelchair training intervention, they would increase push angle, decrease push force, and improve wheelchair skills proficiency.

Background:

The most common type of wheelchair used for everyday mobility by persons with SCI is a manual wheelchair (National Spinal Cord Injury Statistical Center, 2013). Although wheelchair propulsion is an essential skill for maneuvering a manual wheelchair, research suggests that the repetitive loading on the upper extremities may contribute to pain and chronic overuse injuries (Boninger et al., 2005; Gellman et al., 1988). Manual wheelchair users may benefit from training in proper wheelchair propulsion to help decrease the possibility of injuries that may affect their mobility and activities of daily living. Although a relationship between wheelchair propulsion and chronic overuse injuries is documented, clinical guidelines have been developed, and research has been conducted on different approaches, new manual wheelchair users are often given little information or training on how to propel their wheelchairs (Boninger et al., 2002; Best, Routhier, and Miller, 2014).

Design:

A repeated measures within-subject design was used with participants acting as their own controls. Participants: Six persons with an SCI requiring the use of a manual wheelchair participated in a wheelchair training intervention. Participants included four men and two women, average age 38 (\pm 17.5); four participants had thoracic level injuries, and two had cervical level injuries.

Methods:

The intervention included nine 90-minute training sessions. The primary focus was on wheelchair propulsion biomechanics, and the secondary focus was on wheelchair skills. The training program for manual wheelchair users was based on motor learning principles using a repetition-based approach to produce an effective propulsion technique. Research suggests that important components of wheelchair propulsion training are decreasing push frequency, increasing push angle, and using a pattern in which the hand drops below the pushrim toward the axle of the wheel (Boninger et al., 2005; Sawatzky, DiGiovine, Berner, Roesler, and Katte, 2015). During the training sessions, these components were emphasized through verbal feedback from a clinician. The wheelchair skills introduced during each session were used to vary the practice schedules of movement, provide an external focus of attention, and further educate participants on valuable wheelchair skills. At each testing session (Pretest 1, Pretest 2, and Posttest), kinematics related to propulsion and wheelchair performance overground were measured. Kinetic propulsion variables and wheelchair skills were measured immediately before the intervention (Pretest 2) and immediately after (Posttest). During Pretest 1, Pretest 2, and Posttest, wheelchair propulsion biomechanics were measured using the Wheelchair Propulsion Test (WPT; Askari et al., 2013) and a Video Motion Capture (VMC) system. The VMC system was used to quantify the area of the push loop, and hand-to axle relationship during propulsion. Sagittal plane numerical data for the third metacarpal marker on the right hand were calculated relative to the marker placed on the axle of the right wheel. During Pretest 2 and Posttest, propulsion forces (peak and average) and slope of tangential force were measured using data from the WheelMill System (WMS; Klaesner et al., 2014) and wheelchair skills were measured using the Wheelchair Skills Test (WST; Kirby et al., 2013).

Analytical Methods:

A repeated measures analysis of variance (ANOVA) was used to determine whether there were significant differences in the wheelchair kinematic variables and the wheelchair performance variables across three testing times ($p < 0.05$). A paired t-test was used to determine significant differences in the wheelchair push force variables (WMS) and wheelchair skills (WST) variables between Pretest 2 and Posttest ($p < 0.05$).

Results:

Significant changes in area of the push loop, hand-to-axle relationship, and slope of the push forces were found. Changes in propulsion patterns were identified pre- and post-training. No significant differences were found in peak and average push forces and wheelchair skills pre- and post-wheelchair training.

Group comparison:

The slope of the force elicited a significant decrease of 34.3 Newtons per second (95% CI, 5.2 to 63.4) post-intervention

(Figure 1). Participants' forces (average and peak) decreased after the wheelchair training intervention (See Figure 1). However, no significant difference was found for average force or peak force in the paired t-test results.

The wheelchair training intervention elicited significant changes in the area of the push loop ($F(2, 10) = 9.8$), with the area remaining consistent between the two pretest measurements and increasing post-intervention (Figure 2). Post hoc analysis revealed that the area of the push loop significantly increased ($p = 0.05$) from Pretest 2 to Posttest, with a mean difference of 309.7 cm² (95% CI, 5.7 to 613.6). The training intervention also elicited significant changes in the hand-axle relationship pre- and post-intervention ($F(2, 10) = 5.2$), with the distance between participants' third metacarpal and the wheel axle decreasing during recovery between the pretest and posttest assessments (see Figure 2). The wheelchair training intervention did not elicit significant changes in push angle pre- and post-intervention ($F(2, 10) = 3.6$), with the push angle increasing during the push phase between the pretest and posttest assessments (See Figure 2). However, push angle did not increase for all participants.

The recovery item on the WPT (defined as bringing the hand below the pushrim toward the axle during the recovery phase of the push cycle) was found to be significant ($P < 0.01$). The wheelchair training intervention elicited significant changes in the speed (meters per second) to push 10 meters during the WPT ($F(2, 10) = 11.39$). Post hoc analysis revealed that participants' speed across 10 meters significantly increased from Pretest 2 to Posttest, with a mean difference of 0.16 meters per second (95%CI, 0.24 to 0.10; See Figure 3). The wheelchair training intervention elicited significant changes in the push effectiveness (meters per push) across the 10 meters ($F(2,10) = 4.33$; See Figure 3). Post hoc analysis showed no significant changes between each of the assessment points. The wheelchair training intervention did not elicit significant changes in push frequency (pushes per second) before and after intervention ($F(2,10) = 0.45$; See Figure 3).

Wheelchair skills as measured by the WST also showed no significant difference (See Figure 3). All participants' scores increased from Pretest 2 to Posttest; two participants had increases of approximately 14% to 17%, and two participants already had high scores (i.e., 90% and 94%) before training.

Discussion:

Trends in change related to a repetition-based motor learning approach for propelling a manual wheelchair were identified across all six participants. Some participants made changes across all variables and others just a few of the variables. Challenges associated with implementing interventions for new manual wheelchair users, such as recruitment, were experienced. The results of this project are similar to those found in previous wheelchair training research. Studies using components of motor learning, such as visual feedback, found subtle changes in propulsion biomechanics, including longer, slower push patterns similar to the changes found in this study (deGroot et al., 2005; Rice et al., 2013)

Clinicians report that they rarely use validated protocols when teaching wheelchair propulsion and skills during rehabilitation (Best et al., 2014). The results of this study indicate that new manual wheelchair users can tolerate up to 700 practice propulsion repetitions per session and that approximately 5000 repetitions contribute to changes in propulsion patterns. Instruction given during the training sessions was provided

by a clinician and did not require a computer system with feedback. More research is needed to understand "dosing," or the number of repetitions needed to promote the proper propulsion techniques.

This study had many limitations, including a small sample size and heterogeneity (length of time since injury and level of injury) of the participants. The small sample size and short range in time since injury were the result of difficulty recruiting new manual wheelchair users who were medically stable and emotionally ready to work on wheelchair skills. A methodological limitation of the study was that the kinematic data and kinetic (force) data were collected on different surfaces. The force data were collected on a wheelchair roller system, so the force data may not be representative of overground propulsion. Future research is needed to further test repetition-based wheelchair training with a more rigorous research design, to measure kinematics and kinetics at the same time overground, and to examine the retention of propulsion biomechanics and skills after the training sessions. In addition, other factors involved in motor learning—the rate at which new wheelchair users learn and the involvement of depression, motivation, and cognitive processing in the motor learning process—should be evaluated in relation to the training program.

Impact Statement:

The results of this study have clinical implications, as the motor learning principles used in the training program used during this research could be applied to teaching manual wheelchair skills training during rehabilitation.

References

1. Askari, S., Kirby, R. L., Parker, K., Thompson, K., & O'Neill, J. (2013). Wheelchair propulsion test: development and measurement properties of a new test for manual wheelchair users. *Archives of Physical Medicine and Rehabilitation*, 94(9), 1690–1698.
2. Best, K. L., Routhier, F., Miller, & W. C. (2014). A description of manual wheelchair skills training: current practices in Canadian rehabilitation centers. *Disability and Rehabilitation: Assistive Technology*, 10(5), 393–400.
3. Boninger, M. L., Koontz, A., Sisto, S., Dyson-Hudson, T., Chang, M., Price, R., & Cooper, R. (2005). A Pushrim biomechanics and injury prevention in spinal cord injury: recommendations based on CULP-SCI investigations. *Journal of Rehabilitation Research and Development*, 42(3), 9–20.
4. Boninger, M. L., Souza, A., Cooper, R. A., Fitzgerald, S., Koontz, A., & Fay, B. (2002). Propulsion patterns and pushrim biomechanics in manual wheelchair propulsion. *Archives of Physical Medicine and Rehabilitation*, 83(5), 718–23.
5. De Groot, S., Veeger, H. E. J., Hollander, A. P., & van der Woude, L. H. V. (2005). Influence of task complexity on mechanical efficiency and propulsion technique during learning of hand rim wheelchair propulsion. *Medical Engineering and Physics*, 27(1), 41–49.
6. Gellman, H., Chandler, D. R., Petrusek, J., Sie, I., Adkins, R., & Waters, R. L. (1988). Carpal tunnel syndrome in paraplegic patients. *Journal of Bone and Joint Surgery*, 70(4): 517–19.

7. Kirby, R. (2013). Wheelchair Skills Test (WST) Version 4.2 Manual. Halifax, Nova Scotia: Dalhousie University. Retrieved 08/31/2015 from: <http://www.wheelchairskillsprogram.ca/eng/testers.php>.
8. Klaesner, J., Morgan, K. A., & Gray, D. B. (2014). The development of an instrumented wheelchair propulsion testing and training device. *Assistive Technology*, 26(1), 24–32.
9. National Spinal Cord Injury Statistical Center. (2013). Annual Statistical Report—Complete Public Version. Tuscaloosa: University of Alabama.
10. Rice, I. M., Pohlig, R. T., Gallagher, J. D., & Boninger, M. L. (2013). Handrim wheelchair propulsion training effect on overground propulsion using biomechanical real-time visual feedback. *Archives of Physical Medicine and Rehabilitation*, 94(2), 256–263.
11. Sawatzky, B., DiGiovine, C., Berner, T., Roesler, T., & Katte, L. (2015). The need for updated clinical practice guidelines for preservation of upper extremities in manual wheelchair users: a position paper. *American Journal of Physical Medicine and Rehabilitation*, 94(4), 313–324.

Full paper:

Morgan, K. A., Tucker, S. M., Klaesner, J. W., & Engsborg, J. R. (2015). A motor learning approach to training wheelchair propulsion biomechanics for new manual wheelchair users: a pilot study. *The Journal of Spinal Cord Medicine*, 1–20.

Figure 1

Forces (WMS)	Pretest 2	Posttest
Average force (N)	10.9(4.5)	8.0(4.3)
Peak force (N)	20.6(8.6)	16.4(8.4)
Force slope (N/s)*	149.1(72.1)	114.8(56.6)

Note. Mean score(standard deviation); *p < 0.05.

Figure 2

Kinematics (VMC)	Pretest 1	Pretest 2	Posttest
Area of the loop (cm ²)**	34.8(191.8)	27.0(227.1)	336.6(247.5)
Hand-axle (cm)*	26.1(5.1)	27.1(4.5)	19.3(7.3)
Push angle (degrees)	76.8(11.3)	76.1(8.0)	85.6(11.2)

Note. Mean score(standard deviation); *p < 0.05; **Bonferroni significant between Pretest 2 and Posttest.

Figure 3

Performance (WPT & WST)	Pretest 1	Pretest 2	Posttest
Speed (m/s)**	0.98(0.24)	0.90(0.18)	1.07(0.19)
Push effectiveness (m/push)*	0.96(0.21)	0.95(0.21)	1.12(0.24)
Push frequency (push/s)	1.02(0.20)	0.96(0.1)	0.96(0.06)
Skills completion score (%)	—	67.1(23.2)	73.45(18.0)

Note. Mean score(standard deviation); *p < 0.05; **Bonferroni significant between Pretest 2 and Posttest.

Friday

March 3, 2017

SS4: Do We Really Need Big Data?

Jean Minkel, PT, ATP

Do we really need Big Data? Provision of Seating and Mobility services and devices is such an individualized area of service delivery, does it really lend itself to collection of Big Data? Experts will debate this question, providing insight from both sides of the question, from different stakeholder perspectives. Each participant will prepare a 5-6 minute 'pitch' arguing their stance from their own perspective; we will then open to the floor and to the opposing side.

Arguing FOR the need for Big Data:

Don Clayback, representing the perspective of Suppliers, Industry and Government Affairs

Sharon Sonenblum, representing the perspective of Researchers

Jenny Lieberman, representing the perspective of Clinicians

Arguing AGAINST the need for Big Data:

Gerry Dickerson, representing the perspective of Suppliers, Industry and Government Affairs

Bill Miller, representing the perspective of Researchers

Cindi Petito, representing the perspective of Clinicians

Learning Objectives:

Upon completion of this session, attendees will be able to;

- Describe the difference between traditional research data and Big Data.
- Identify the perspectives of 3 different stakeholder groups who could be involved in the collection and use of Big Data.
- List 1 pro and 1 con for the use of Big Data in the field of complex rehab technology.

References:

1. Marr, Bernard, (2015). How Big Data is Changing Healthcare. Forbes (online).
2. University of Texas Medical Branch, (n.d.). Big Data Collaboration Fuels Rehabilitation Research. UTMB Academic Enterprise (online magazine).
3. Horvath, M. (2015). The Other F-Words: Fear, Frustration, and Fascination with Big Health Data. TWAdmin.

IC25: The Other Seat!

Sharon Sutherland (Pratt), PT

Where else is Skin Integrity preservation and postural management a critical consideration for individuals who use wheelchairs as a primary mode of mobility? In the bathroom of course!

A lot of time and resources are invested on skin integrity preservation and positioning strategies to help reduce the incidence of sitting-acquired decubitus ulcers and postural deviations while sitting in manual and power wheelchairs. Regrettably, these individuals are still at significantly high risk of the same seating challenges if they are using improperly configured and poorly adjusted rehab shower commode chairs (RSCCs). When I originally thought about this topic from the perspective of a clinician who has specialized in positioning, seating and mobility for the past 28 years and who loves to share clinical thoughts and best practices, my approach was to consider the clinical and functional needs of such individuals in conjunction with the seating and positioning attributes of rehab shower commode chairs.

Lets first think about who might benefit from rehab shower commode chairs. It would be any person with a mobility impairment who experiences prolonged bowel / hygiene routines and who may be at risk of pressure injuries. For example, persons presenting with Spinal Cord Injuries; Traumatic Brain Injuries; Cerebral Palsy, Multiple Sclerosis, ALS and Bariatric and/or Elderly clients with functional limitations.

An RSCC is a very important piece of equipment that needs thoughtful consideration for these clients for the following reasons:

- Provides safe transport to and from the bathroom or within the bathroom between the toilet and shower for non-ambulatory or barely ambulatory users;
- Provides safe positioning and skin integrity preservation for users who are at risk of decubitus ulcers from bowel and bathing programs lasting one to three hours or more;
- Eliminates unnecessary transfers which is very important for both the client and carer safety
- Can be the 2nd most important mobility device! - It is indeed the "other seat."

As inpatient stays become shorter and shorter, it is critical that we pay as much attention to the seating used in the bathroom as we do to the seating used in wheeled mobility. Just as for a wheeled mobility assessment, the home environment detail is critical; however for this article I am focusing more on the positioning and skin integrity needs of the clients who use RSCCs as opposed to the home environment details.

An interesting fact that I uncovered as I prepared to discuss this topic: "The ideal posture for Defecation is the full squat, which provides the abdominal muscles with the proper support during the expulsion process, as contrasted with the familiar "sitting on a chair" posture that is so commonly assumed on a standard toilet or toilet seat. In the "sitting-on-a-chair" posture the person trying to empty the bowel is essentially passive and unable

to aid the body's natural mechanism of evacuation" For more information on this topic, I encourage you to read "A Guide to Better Bowel Care: A Complete Program for Tissue Cleansing Through Bowel Management." In this guide, chiropractic physician and nutritionist Dr. Bernard Jensen identified the sitting toilet as a health threat to mankind: I quote from this guide "It is my sincere belief that one of the bowel's greatest enemies in civilized society is the ergonomic nightmare known as the toilet or john."

This means that toileting, even with intact neuromuscular control, can be challenging to the body from the seated position.

Important clinical facts that should be considered during the assessment process and the selection/prescription of rehab shower commode chairs related to skin integrity preservation include:

1) Anthropometrics – the client's bony dimensions

When considering seat supports in the bathroom, the client's very narrow ischial base of support is a critical consideration (Figure 1).

Figure 1

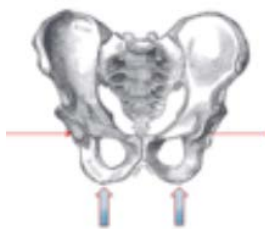

In the commode seat, the aperture width/size is an important consideration, not only for skin protection, but also for stability. Generally the ischials are "in the hole," which means the load is being taken on the undersurface of the greater trochanters. This

means that we need to know where the client's ischials are as well as where their load-bearing surfaces are. Remember the pelvic size doesn't grow once we become adults... "Bummer...it's not that we have big bones like Momma said!" Anthropometrics don't lie! In an adult male the distance between Ischials is approximately 4-4.5" In an adult female the distance between ischials is approximately 5-6.5" The general width between the undersurface supporting area on the trochanters is approximately 9-11', so regardless of overall body width, the pelvis, femurs and the surrounding soft tissue must be supported. We can't have "falling in" or the potential for high-pressure areas.

2) Skin integrity presentation – Is your client...

- o High risk
- o Moderate risk, or
- o Low risk for skin integrity issues?

Consider the length of time in position for bowel bladder management regimens, as well as for shower regimens, as this will tell us a lot about weight shifting technique and therefore help guide us with necessary features in the RSCC. An excellent reference for best practice guidelines is www.npuap.org

- The National Pressure Ulcer Advisory Panel - NPUAP

- » Resources » Educational and Clinical Resources » Pressure Ulcer Prevention Points/updated 04-2016
- <http://www.npuap.org/resources/educational-and-clinical-resources/prevention-and-treatment-of-pressure-ulcers-clinical-practice-guideline/> updated 2014

2) Postural/functional clinical presentation

Does the client present with...

- Anterior pelvic tilt and compensating lordosis;
- Posterior pelvis tilt and compensating kyphosis;
- Pelvic obliquity +/- rotation and compensating scoliosis and wind sweeping?

Consider also...

- The support and space needed during transfers;
- What's needed to lean side to side and stabilize while "taking care of business" independently;
- What's needed when an assistant is involved for the toileting detail?

I think of postural support in terms of...

- Inferior and posterior support as our primary support surfaces (support provided under the client, i.e. seat and feet, and behind the client, i.e. back support);
- Gravity assist as necessary for postural support/stability and/or weight shifting;
- Lateral and /or anterior support as the assistants to the primary support surfaces; Consider for what activity and what duration: the purpose.

How do we translate this clinical information collected during the hands-on assessment into essential or desirable RSCC attributes?

Clinical finding:

1. Anthropometrics – bony dimensions

Related essential features:

- a. Aperture: (the hole in the seat)
 - i. Dimensions: We should measure this for accuracy related to client dimensions.
 - ii. Location.
- b. Access point location (example figure 2)

Figure 2



(kyphosis);

- c. Pelvic obliquity and rotation (scoliosis-wind sweeping).

Related essential features:

- i. Aperture and support surface shape;
- ii. Seat adjustability/customization (example figure 3);

Figure 3

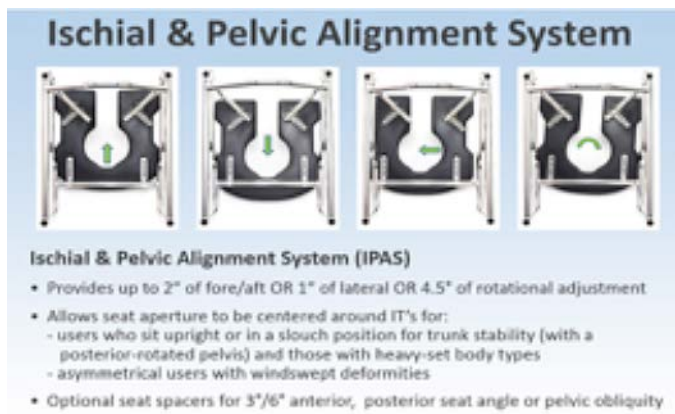

- iii. Back support adjustability;
- iv. Feet support adjustability.

Clinical finding:

3. Skin integrity presentation: Is the individual...
 - a. High risk,
 - b. Moderate risk, or
 - c. Low risk for skin integrity issues?

Related essential features:

- i. Support surface material/contact area:
 1. Pressure distribution/shape and material;
 2. Ease of transfers/shear reduction/yet enough friction for wet bodies.

Clinical finding

4. Length of time in position for bowel / bladder management regimens as well as for shower regimens:

Related essential features:

- i. Weight shift ability... Independent or dependent (tilt for example)?
- ii. Arm supports/location/weight-load tolerances;
- iii. Foot loading ability;
- iv. Back support ability for optimally loading/set up:
 1. Ask "What are the options available?"
 2. Can I adjust angle and height to get the desired posterior loading/support necessary for my client?
 3. Is seat depth, or where the client's buttocks are positioned, impacted by the back support?
 4. Just as in the wheeled mobility world, no seat works without optimal posterior loading.
 5. Is it easy to clean and does it comply with infection control?
- v. Lateral and or anterior assisting supports:
 1. Example: Flip-back armrests with 45-degree hand grips (figure 4)

Figure 4



Along with the essential home environment, functional, postural and skin integrity assessment, I was curious if Interface Pressure Mapping (IPM) could be helpful in our clinical decision-making? My conclusion: absolutely, why not? This is a well recognized adjunct to our clinical assessment tools in the world of seating for wheeled mobility and can be utilized very effectively in the selection of the ideal RSCC seat also. Figure 5 is an example of interface

pressure mapping images showing a comparison — same patient/client sitting on three different RSCCs. All three images with the client in most relaxed position: ischials in the aperture. In this case the use of IPM was very helpful as an assistant to the clinical decision making where identification of the bony prominences and skin integrity preservation was a priority.

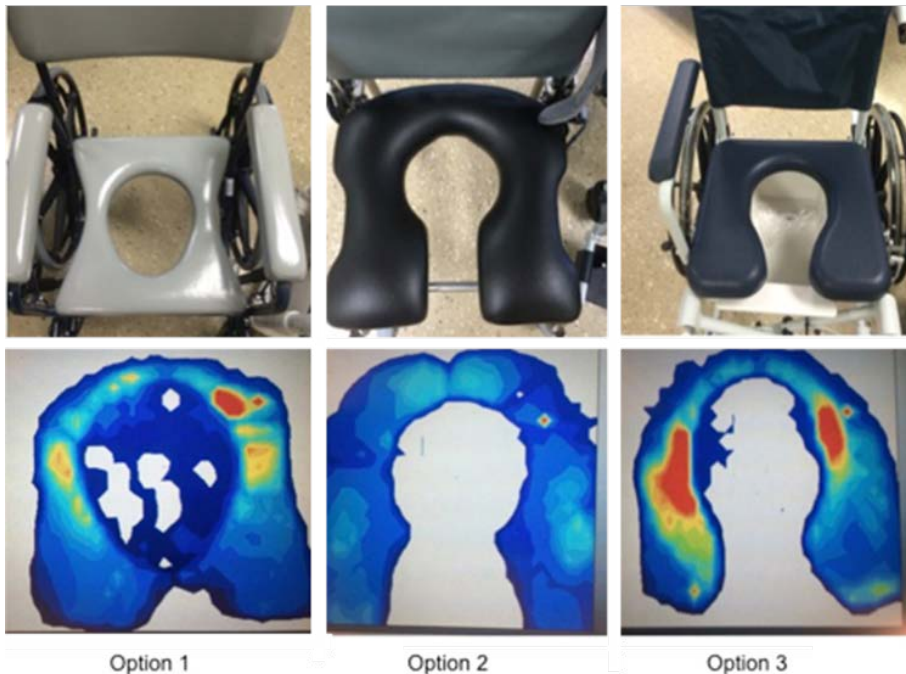

Option 1

Option 2

Option 3

Interface pressure mapping can also be very helpful with identifying the optimal set up of foot supports, back support and the required amount of orientation/gravity assist for stability and postural alignment. As always, it can also be utilized to provide education to the client, carer and clinician with regard to optimal load distribution as well as weight shifting effectiveness.

This is a summary of what I have learned from using IPM when looking at RSCCs:

1. Size, location and shape matters when it comes to the relationship between the buttocks, (the bony structures/tissue) and the aperture;
2. Seat Material matters when it comes to load distribution initially as well as over time;
3. Back support matters when we are looking at positioning as well as load distribution;

4. Utilizing tilt can be essential for both postural support as well as for weight shifting when bowel/bladder shower routines extend into the recommended skin integrity plan of care.

The clinicians who I have worked with on this subject matter were amazed regarding the differences among the pieces of equipment that they used daily. They believe they will continuously pay more attention to what they are prescribing for clients who are at risk for skin integrity issues and who will be using RSCCs for any length of time.

References:

1. Dr. Bernard Jensen: A Guide to Better Bowel Care: A Complete Program for Tissue Cleansing Through Bowel Management
2. <http://emptyingthebowel.com/images/stories/thessquattloostool.png>
3. The National Pressure Ulcer Advisory Panel - NPUAP » Resources » Educational and Clinical Resources » Pressure Ulcer Prevention Points
4. <http://www.npuap.org/resources/educational-and-clinical-resources/prevention-and-treatment-of-pressure-ulcers-clinical-practice-guideline/>

Contact Information:

Email: sharronpra@msn.com
Website: www.seatingsolutionsllc.com

IC26: Rehab on the Ropes: Round 2 of the CMS Competitive Bid

Deborah L. Pucci, PT, MPT
Jessica Presperin Pedersen

1. History of Centers for Medicare and Medicaid Services (CMS) Competitive Bidding Program 2009-2017
2. Mobility characteristics of Medicare beneficiaries impacted by Competitive Bidding Program
3. Mobility equipment included in Competitive Bidding Program
 - a. Manual Wheelchairs
 - i. K001-description and documentation requirements per CMS
 - ii. K002-description and documentation requirements per CMS
 - iii. K003-description and documentation requirements per CMS
 - iv. K004-description and documentation requirements per CMS
 - b. Power operated vehicle (POV)
 - c. Power wheelchairs
 - i. Group 1-description and documentation requirements per CMS
 - ii. Group2-description and documentation requirements per CMS
 - d. General purpose cushions
 - e. Accessories
4. Supplier obligations as outlined by the CMS contract
5. Reimbursement
6. Choosing the supplier that meets the patient needs
 - a. Group 2 with seating function and positioning supports
 - b. K004 with skin protection cushion
7. Paradigm shift in how seating procurement for people using competitive bidding is accomplished
8. Systems change at a large rehabilitation center
 - a. Determination of who performs evaluation
 - i. primary therapist
 - ii. seating clinic therapist
 - b. Educating primary therapists
 - i. Physical ability
 - ii. Functional Ability
 - iii. Linear Measurements
 - iv. Angular Measurements
 - v. Environmental Considerations
 - vi. Documentation
 - c. Communication with the supplier
 - d. Educating the patient
 - e. Fitting and delivery
 - i. Inpatient
 - ii. Outpatient

References

1. Reference 1: Pedersen JP, Harmon D, Kirschner KL. (2014). Is an appropriate wheelchair becoming out of reach? Part 1. PM R, Jul;6(7):643-9.
2. Reference 2: Reis JP, Ballerini. K, O'Farrell S, Jasch C, Boninger M, Duerden M, Kirschner KL. (2014). Is an appropriate wheelchair becoming out of reach? Part 2. PM R, Oct;6(10):934-44.
3. Reference 3: Song Z, Cutler DM, Chernew ME. (2012). Potential consequences of reforming Medicare into a competitive bidding system. JAMA, Aug 1;308(5):459-60.
4. Reference 4: Center for Medicare and Medicaid Services. (2016). Competitive Bidding Program In Medicare.gov. Retrieved from <https://www.medicare.gov/what-medicare-covers/part-b/competitive-bidding-program.html>
5. Reference 5: Waugh, K., and Crane, B. (2013). A Clinical Application Guide to Standardized Wheelchair Seating Measures of the Body and Seating Support Surfaces (Rev. Ed). Denver, CO: University of Colorado Denver (363 pgs). Retrieved from <http://www.ucdenver.edu/academics/colleges/Engineering/research/AssistiveTechnologyPartners/resources/WheelchairSeating/Pages/WheelchairGuideForm.aspx>

Authors

Deborah L. Pucci, PT, MPT

Rehabilitation Institute of Chicago, 345 East Superior Street,
Chicago, IL 60611
Phone: 312.238.6012
Email: dpucci@ric.org

Jessica Presperin Pedersen, OTR/L, ATP/SMS

Rehabilitation Institute of Chicago, 345 East Superior Street,
Chicago, IL 60611
Phone: 312.238.29.64
Email: jpedersen@ric.org

IC27: Positioning the Head

Michelle L. Lange, OTR/L, ABDA, ATP/
SMS

Not everyone who uses a wheelchair requires head positioning. Sometimes a head support is required only for safety in transportation if the client travels seated in their wheelchair. A head support may only be required to provide posterior support during tilt or recline. Many clients do have decreased head control and may require specific seating interventions as a result.

Decreased Head Control

If a client has difficulty bringing and maintaining their head in an upright and aligned posture, head control is decreased. Decreased head control may be the result of decreased neck strength, forward flexor tone or even a visual impairment (specifically, a vertical midline shift). The position of the neck is greatly influenced by the position of the spine. If the spine has a lateral curve or scoliosis, this can lead to lateral lean of the head. If the spine is forward flexed or kyphotic, the neck will tend to flex. Unless the kyphosis is accommodated within the seating system, if the client attempts to lift the head, the neck will be hyperextended.

Before looking at specific interventions for head control, it is critical to optimally position the pelvis and trunk to optimize head control. The head, in most cases, should be positioned over or just behind the pelvis to allow the client to balance the head.

Interventions for decreased head control primarily consist of various styles of posterior head supports. Most of these only provide support at the occiput, but some add a suboccipital support, providing additional contact and minimizing hyperextension. Lateral support is also available, as needed.

No Head Control

Clients with no head control cannot achieve or maintain an upright head position without significant support, often anterior to the head. Severely decreased neck strength is sometimes seen in clients with conditions such as amyotrophic lateral sclerosis (ALS), spinal muscular atrophy (SMA) type I, congenital myopathies, as well as in clients with extremely high level spinal cord injuries. In the case of absent head control, support is required anterior to the head, typically at the forehead or under the jaw, or superior to the head. Anterior supports include forehead straps, rigid swing-away anterior forehead pads, or collars. Superior support is provided above the head and is available in one product at this time.

Goals of addressing decreased and absent head control are to:

- align the neck for improved swallow, breathing, and vision
- improve functioning
- prevent overstretching of the neck extensors which could further worsen head control

Case Study 1

“Ryan” was initially seen to determine the optimal switch placement for access to a speech generating device. His positioning was quite poor and led to extreme neck hyperextension and choking (see figure 1). Modifications were made to his wheelchair seating system which placed his pelvis in a neutral position, however his hyperextended neck position persisted as his trunk was still flexed forward (see figure 2). After the anterior trunk support was adjusted so that his trunk was upright and his neck was aligned, Ryan was able to better breathe, swallow, visually regard his environment and access a switch (see figures 3 and 4).

Figure 1: Seating in Classroom Chair

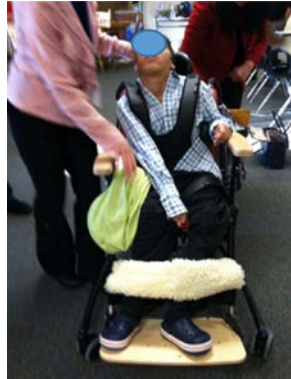

Figure 2: Neutral Pelvis With Forward Trunk Flexion Leading To Hyperextended Neck



Figure 3: Positioning With Anterior Trunk Support and Resultant Aligned Neck Posture



Figure 4: Switch Placement



Figures 7 and 8: Cindy Case Study



Right lateral support to maintain midline position and suboccipital pad to minimize hyperextension

Case Study 2

“Cindy” is a 14 year old young lady with the diagnosis of cerebral palsy. She had a posterior head support, but her head position was poor. She leaned to her right side and propped her head on her chest with her neck hyperextended (see figures 5 and 6). A new head support was trialed that included a right lateral support to keep her head in midline and a suboccipital support to minimize neck hyperextension (see figures 7 and 8). She can now keep her head in midline, better attend visually to her environment and it is easier and safer for her to eat. With this head support, Cindy was able to access a switch to control her assistive technology.

Conclusion

Positioning the Head involves far more than choosing the best head support. It is critical to ensure that the client's overall position facilitates an upright and balanced head. The evaluator must determine why the client's head is in a “less than optimal” placement to determine the best solution. An upright and aligned head is optimal, when possible, to support breathing, swallow, and visual regard.



Figures 5 and 6: Cindy Case Study
Head leaning to right, neck hyperextended and propped

IC28: How do we learn the skills to become seating therapists?

Rhona Moot, OT BSc(Hons)

Stephanie Tanguay, OT/L ATP

Paula. W. Rushton, OT, PhD

Mary Goldberg, PhD

BACKGROUND

There is a noticeable lack of seating and mobility knowledge among junior therapists in rehabilitation settings. Indeed, the lack of education provided by health care professional programs in specific areas, such as wheelchair skills training, has been confirmed in a recent study¹. As a result of this lack of education, therapists are often required to undergo additional continuing education (e.g., conference workshops), 'on the job' training (e.g., often through mentorship from more senior therapists) and self-directed learning. This situation had raised the awareness of the need for both improved rehabilitation professional education standards, as well as opportunities for continuing education.

International organizations and individual clinicians alike have recognized this need for improved education for health care professionals who are involved in the wheelchair service provision process. The International Society of Wheelchair Professionals (ISWP), for example, is an organization that is dedicated to professionalizing wheelchair services so that everyone in the world who requires a wheelchair has access to an appropriate one. As one means of achieving this ultimate goal, the ISWP is conducting research to understand current educational needs and potentially inform changes to university curricula and continuing education opportunities. Similar research is being conducted at the individual clinician level.

The objectives of this ongoing, collaborative work are to better understand: (a) 'how we learn the skills to become seating therapists' and (b) the current global situation of wheelchair service provision education. This presentation will share findings from this ongoing, collaborative work.

METHODS

Design

To address our objectives, we used both cross-sectional surveys and qualitative interviews to collect the data.
Sample and Recruitment Procedure

To respond to objective 1, to better understand 'how we learn the skills to become seating therapists', occupational and physical therapists were recruited to participate in an online survey via seating associations and contacts working in the field of seating and mobility in five European countries

plus the US and Canada. To respond to objective 2, to better understand the current global situation of wheelchair service provision education, representatives of university health care professional programs (e.g., occupational therapy) were recruited to participate in an online survey and qualitative interviews via the International Society of Wheelchair Professionals listserv and purposive sampling respectively.

Data Collection

How do we learn the skills to become seating therapists? This 19-question online survey was distributed between April to June 2016. Sample questions included: "During your OT or PT course, what kind of education on seating and mobility did you receive?" "Give an indication of how long education on this topic lasted?" and "If you received any education on seating and mobility at University did this help prepare you for working in this area?"

What is the current global situation of wheelchair service provision education?

This 27-item survey, developed by the ISWP, was distributed between August to September 2015. Sample questions included: "Does your education curriculum currently include content focused on wheelchair service delivery?" and "Did you and/or your institution develop your own training material?" As a follow-up to this survey, the ISWP is currently conducting qualitative interviews with a selection of survey respondents and other targeted individuals who are able to speak to their respective educational institution's wheelchair-related content. The interviews are being conducted by members of the ISWP using a semi-structured interview guide. Sample questions include: "Could you describe your profession's scope of practice related to wheelchairs? Do you think it's adequately covered in your curriculum?" Interviews are being audio recorded and transcribed verbatim.

Data Analyses

Survey data were analyzed using summary statistics (e.g., means, percentages). Qualitative interview data is being analyzed using content analyses (codes, categories, themes).

RESULTS

How do we learn the skills to become seating therapists? A sample of 126 occupational and physical therapists responded to this survey, Almost half of these respondents reported that they had received less than one day of education on seating and mobility at university. Sixty-five percent of respondents stated that the training they had received upon starting their career as a seating therapist was inadequate in preparing them for this role. Overall, 91% of respondents reported that they had sought additional training to carry out their job.

What is the current global situation of wheelchair service provision education?

A sample of 72 respondents from 21 countries responded to this survey. Seventy-five percent of respondents of educational institutions reported that they taught wheelchair-related content in their professional rehabilitation programs, however the content and time dedicated to this topic varied considerably across institutions.

To date, 7 interviews have been conducted with representatives of educational institutions across 4 different continents. Preliminary data analyses are describing current wheelchair-related content being taught, as well as facilitators and barriers to the integration of current and desired content into university health care professional program curricula.

Address of contact person:

Rhona Moot, OT, BSc (Hons)

Invacare
Galvanistraat 14-3
6717 AE
Ede
The Netherlands
rmoot@invacare.com

DISCUSSION

This presentation describes how skills are learned to become seating therapists and the current wheelchair service provision education worldwide. This collaborative work found variability in wheelchair service provision education, which may explain the need for 'on the job' training for junior therapists. Limited education in this area was a consistent finding in both surveys and the qualitative interviews. Currently taught content and the barriers and facilitators being explored in the qualitative interviews will inform recommendations for integration of wheelchair-related content into university curricula.

Funding/Support

Research conducted by the ISWP was funded by grant number APC-GM-0068 provided through JSI Research and Training Institute and the US Agency for International Development.

References

1. Best, K. L., Routhier, F., & Miller, W. C. (2014). A description of manual wheelchair skills training: Current practices in Canadian rehabilitation centers. *Disability and Rehabilitation: Assistive Technology*, 10(5), 393-400. doi:10.3109/17483107.2014.907367

Disclosure

We (Rhona Moot, Stephanie Tanguay, Paula W. Rushton & Mary Goldberg) do not have an affiliation (financial or otherwise) with an equipment, medical device or communications organization mentioned or used in these studies.

IC29: What Happens When You Sit? Explaining Seated Buttocks Deformation.

Sharon Eve Sonenblum, PhD
Stephen H. Sprigle, PhD, PT

Introduction

Over the past decade, pressure injury research has implicated tissue deformation in pressure injury development. Pressure injuries develop when external loads deform internal tissues, leading to a series of pathophysiological responses and eventually cell death.

To date, models of pressure injury etiology focus on three areas: 1) direct cell damage from prolonged deformation, 2) (deformation-induced) ischaemia of soft tissues, and 3) a (deformation-induced) disruption in the equilibrium in the lymphatic system [1, 2]. When sitting, the external loads often measured with interface pressure mapping are transmitted through the body to internal tissues, which respond by experiencing stress and deformation of their own.

The Role of Tissue Deformation in Pressure Injury Development

Investigations of tissue response to loading with respect to pressure injury development have focused most on muscle tissue. Presumably, this is because of the assumption that muscle is the tissue experiencing greatest loads under the ischial tuberosity, although that assumption has been called into question by our research [3, 4]. In 2003, Breuls et al [5] deformed simulated muscle tissue and found that the dead cells were evenly distributed beneath the indenter. Because damage resulting from oxygen deprivation would be expected to be unevenly distributed, with more damage occurring farther from the undeformed tissue, this study provided early evidence of direct deformation damage. Stekelenburg et al expanded on this work in 2006 [6] by pushing on a rat's hind leg for two hours. They found significant changes in the tissue over the hours following, including disorganization of internal structure of muscle fiber, an extensive inflammatory response, and large necrotic regions. Another study in 2007 tested the hypothesis that direct deformation damage exists, and did so by testing strained tissue under hypoxic and normoxic conditions [7]. Two key findings were that tissue damage occurs in presence of normal oxygenation and that direct deformation damage is faster than ischaemic damage.

Fewer studies have

investigated skin and adipose responses to deformation, although interest in these tissues is growing slowly. In an extensive review of pressure ulcer tissue histology, Dr. Edsberg [8] described skin around a stage II pressure injury and observed disruption of dermal papillae, densely packed collagen, necrosis of skin appendages, and the presence of inflammatory cells. In 2013, Stojadinovic, O., et al. [9] studied young and aged skin and found they responded differently to loading. Aged skin experienced changes to collagen alignment and subepidermal separation that were not present in young skin.

The differences in aged skin demonstrate how a common risk factor such as age impacts the mechanical structure and properties of the tissue. These changes in mechanical properties modify the tissue's response to loading, providing an explanation for how and why risk factors (such as age in this case) actually increase risk.

The spectrum of risk that exists in high-risk populations such as wheelchair users can be stratified in large part by an individual's Biomechanical Risk, or the intrinsic likelihood of their buttocks tissue to deform in response to loading. Characteristics described above, such as age and BMI, change an individual's Biomechanical Risk, as do things like diagnosis, smoking, and hydration. Unfortunately, our limited understanding of the effects of many clinical factors on Biomechanical Risk restricts our options for identifying the highest risk individuals. As a result, it is difficult to personalize interventions that would respond directly to individuals' Biomechanical Risk.

Differences in Biomechanical Risk

Presented below is an illustration of the adipose tissue (inferior and superior surfaces) of the seated buttocks of 3 similarly aged men with different levels of risk (Figure 1) [4]. Subject G experienced complex adipose deformations, particularly compared with Subject A whose adipose deformed rather uniformly. In the absence of any other information, this clearly illustrates an at-risk buttocks, which is consistent with his history of recurrent pressure injuries on the contralateral side.

Figure 1. Reproduced from [4]. Renderings of the subcutaneous adipose tissue near the IT when seated on foam.

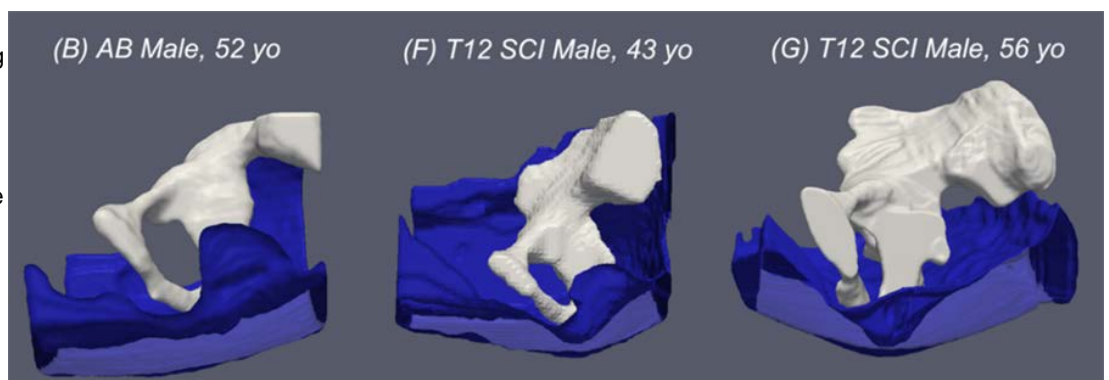

Differences Across Sitting Surfaces

Shape Compliance is defined as the ability of a cushion to support the buttocks with minimal buttocks deformation. It can be considered a metric of cushion performance. Shape Compliance has yet to be measured on human buttocks, but preliminary investigations into the loaded buttocks (specifically highly atrophied buttocks) on commercial wheelchair cushions are currently undergoing analysis. Illustrated below (Figure 2) are coronal and sagittal views of an individual's buttocks seated on 3 different surfaces: an orthotic based offloading cushion (Java, Ride Designs), a pressure redistribution cushion made with contoured foam (Matrx, Invacare), and a pressure redistribution cushion that uses air flotation (Roho, Permobil). The pelvis is visible through the semitransparent skin rendering, as is the gluteus maximus in red. This research participant is a 44 year old man. He is 18 years post injury with a complete T5-6 level SCI. He presents with significant atrophy, very little tissue around the pelvis, and he has a history of pressure injuries, suggesting that he has a high biomechanical risk.

We can make a few observations from these images. First, this participant demonstrates a similar amount of tissue present beneath the peak of the ischial tuberosity for all surfaces. At the same time, the curvature of the buttocks in that region differs suggesting different tissue strain profiles. Second, the contact area and immersion is different on each cushion. Visible by the discontinuity in contour as you travel from the inferior to superior surfaces of the buttocks, the contact area on the Java is considerable in the posterior-lateral location. Immersion on the Roho was greater than that on the Matrx, suggesting that body weight was spread over a greater surface area. Third, we observed that the gluteus maximus does not wrap underneath the ischium in any condition presented below, but it is displaced more significantly in the superior and lateral directions when seated on the Matrx and Roho than on the Java. Given that the gluteus maximus does not wrap underneath the ischium, more attention must be paid to the adipose and connective tissue present under the ischium.

Figure 2. 3D renderings of the right side of the buttocks viewed laterally (top) and from the posterior (bottom). Adipose tissue is presented as semitransparent, with gluteus maximus in red and the pelvis in a dark gray.

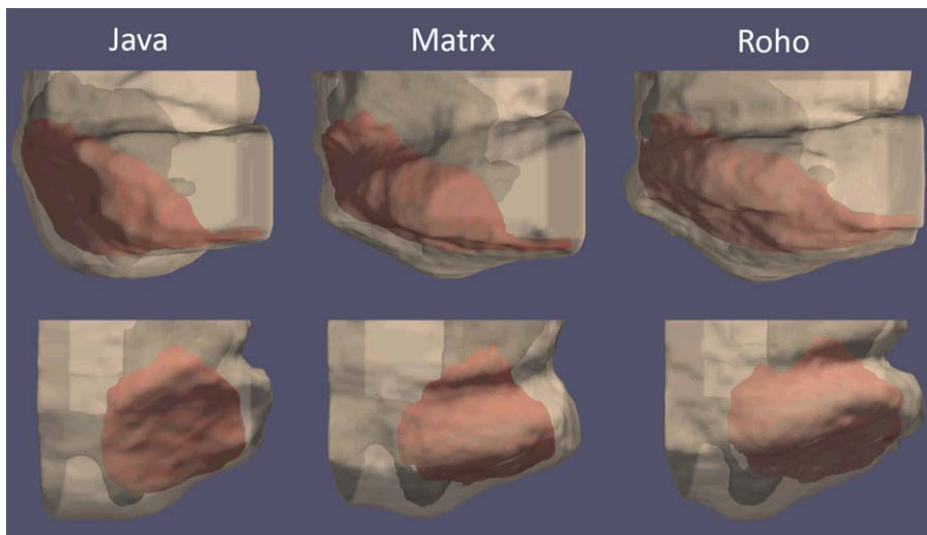

Differences Across Postures

In a recent study of new wheelchair users, the majority reported scooting their buttocks forwards and sitting with a posterior pelvic tilt throughout the day (i.e., sacral sitting or slouching). Tissue deformation that occurs in response to slouched sitting is also important to investigate. Below is an example of the sacral area of a participant while seated on a foam contoured cushion (Embrace, Comfort Company). The participant started as upright as we could achieve and the slouched posture included approximately 8 degrees of posterior pelvic tilt from the upright posture. Significant changes to the tissue contour are visible in the slouched posture compared with the upright posture.

Figure 3. Sagittal MRI slices through the midline of the sacrum in the upright (left) and slouched (right) postures. The middle image shows upright (red) and slouched (green) presented overlapped so differences are visible.

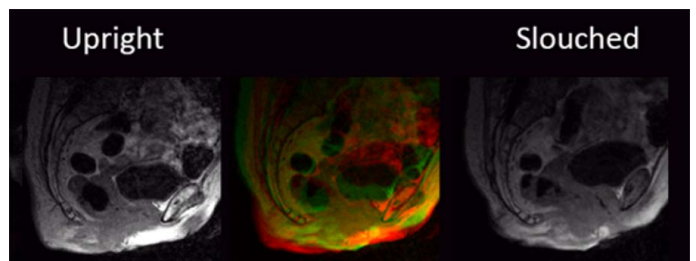

Conclusion

Tissue deformation, including displacement of the muscle and compression of the adipose tissue, is present when seated on all surfaces. But different types of wheelchair cushions manage that deformation using different strategies and with differing results. Further investigation of the buttocks tissue during sitting as compared with unloaded upright sitting will allow us to better describe how different wheelchair cushions work and the impact of altering sitting posture on tissue deformation.

References

1. Bouten, C.V., C.W. Oomens, F.P. Baaijens, and D.L. Bader, The etiology of pressure ulcers: skin deep or muscle bound? *Arch Phys Med Rehabil*, 2003. 84(4): p. 616-9.
2. Oomens, C.W., D.L. Bader, S. Loerakker, and F. Baaijens, Pressure induced deep tissue injury explained. *Ann Biomed Eng*, 2015. 43(2): p. 297-305.
3. Sonenblum, S.E., S.H. Sprigle, J.M. Cathcart, and R.J. Winder, 3-dimensional buttocks response to sitting: a case report. *J Tissue Viability*, 2013. 22(1): p. 12-8.
4. Sonenblum, S.E., S.H. Sprigle, J.M. Cathcart, and R.J. Winder, 3D anatomy and deformation of the seated buttocks. *J Tissue Viability*, 2015. 24(2): p. 51-61.
5. Breuls, R.G., C.V. Bouten, C.W. Oomens, D.L. Bader, and F.P. Baaijens, Compression induced cell damage in engineered muscle tissue: an in vitro model to study pressure ulcer aetiology. *Ann Biomed Eng*, 2003. 31(11): p. 1357-64.
6. Stekelenburg, A., C.W. Oomens, G.J. Strijkers, K. Nicolay, and D.L. Bader, Compression-induced deep tissue injury examined with magnetic resonance imaging and histology. *J Appl Physiol*, 2006. 100(6): p. 1946-54.
7. Gawlitta, D., W. Li, C.W. Oomens, F.P. Baaijens, D.L. Bader, and C.V. Bouten, The relative contributions of compression and hypoxia to development of muscle tissue damage: an in vitro study. *Ann Biomed Eng*, 2007. 35(2): p. 273-84.
8. Edsberg, L.E., Pressure ulcer tissue histology: an appraisal of current knowledge. *Ostomy Wound Manage*, 2007. 53(10): p. 40-9.
9. Stojadinovic, O., J. Minkiewicz, A. Sawaya, J.W. Bourne, P. Torzilli, J.P. de Rivero Vaccari, W.D. Dietrich, R.W. Keane, and M. Tomic-Canic, Deep tissue injury in development of pressure ulcers: a decrease of inflammasome activation and changes in human skin morphology in response to aging and mechanical load. *PLoS One*, 2013. 8(8): p. e69223. PMID: PMC3743891

Acknowledgements

This work was supported by generous donations from Comfort Company, Ride Designs, and Vicair. We also would like to acknowledge the support of Tom Hetzel from Ride Designs who assisted with the logistics of data collection and subject management during data collection. John Greenhalgh, PhD and Eric Stewart also provided instrumental support on MRI protocol development and data acquisition. The contents of this conference paper were also supported by a grant from the National Institute on Disability, Independent Living, and Rehabilitation Research (NIDILRR grant number 90IF0120).

IC30: Power Mobility for Children with Multiple Severe Disabilities

Lisa K. Kenyon PT, DPT, PhD, PCS

John Farris, PhD

Introduction:

Children who have severe motor, cognitive, and communication deficits are often limited in their ability to use self-initiated movement to explore and learn from the world around them. Such children are frequently dismissed as “too involved” or “too low functioning” to use power mobility. This paper offers an overview of the power mobility training interventions used in the Grand Valley Power Mobility Project (Kenyon, Farris, Brockway, Hannum, & Proctor, 2015; Kenyon et al., 2016), an interprofessional service and research project that provides power mobility training for individuals with multiple, severe disabilities from infancy to 26 years of age. Benefits of Power Mobility Use:

Although the numerous advantages of power mobility use for children with mobility limitations are well documented (Livingstone & Field, 2014), the potential benefits of power mobility training for children who have multiple, severe disabilities are just beginning to be recognized. Increased attention and alertness, development of cause and effect skills, and increased social as well as cognitive skills have all been associated with power mobility training in this population (Kenyon et al., 2015; Kenyon et al., 2016; Nilsson & Nyberg, 2003; Nilsson, Nyberg, & Eklund, 2010; Nilsson, Eklund, Nyberg, & Thulesius 2011). In addition, through practice and repetition, purposeful driving skills may emerge that allow these children to engage in self-exploration of their environment thus providing a plethora of decision-making and problem-solving opportunities and experiences (Kenyon et al., 2015; Kenyon et al., 2016; Nilsson & Nyberg, 2003; Nilsson et al., 2010; Nilsson et al., 2011).

Power Mobility Training Interventions

Durkin (2009) suggests that therapists should strive to achieve a power mobility training atmosphere that promotes a responsive partnership between the child and the therapist well simultaneously fostering functional use of a power mobility device. As opposed to teaching a child specific power mobility skills, this responsive partnership is used to promote exploration and play while encouraging power mobility skills within a context that is meaningful for the individual child (Durkin, 2009). Building on these principles, the power mobility training interventions provided through the Grand Valley Power Mobility Project are designed to actively involve children in individually motivating activities within an engaging environment that is specifically structured to elicit basic power mobility skills. The following standardized steps are used to individualize the training methods and to meet the needs of each child (Kenyon et al., 2016): (1) identification

of specific motivational and reinforcement factors for each individual child through use of the parent interview outlined in the Reinforcement Assessment for Individuals with Severe Disabilities (RAISD; Fisher, Piazza, Bowman, & Amari, 1996); (2) formation of child-specific goals using the Power Mobility Training Tool (PMTT; Kenyon, Farris, Cain, King, & VandenBerg 2015); and (3) creation of an engaging environment designed to target the emergence of the basic power mobility skills outlined in the child’s specific goals. A custom-made attendant control unit is used to “share” control of the power mobility device as a means by which to respond to the learning and safety needs of each child during power mobility training activities. Individualized verbal and physical prompts based upon the child’s preferences as identified through the RAISD are used to encourage the child’s active participation in the training.

Outcomes:

Although not every child who has multiple, severe disabilities will “qualify” for his/her own power wheelchair, preliminary data indicates that these training methods may assist children and adolescents who have multiple, severe disabilities to develop basic power mobility skills (Kenyon et al., 2015; Kenyon et al., 2016; Nilsson & Nyberg, 2003; Nilsson et al., 2010; Nilsson et al., 2011). Recent work by Livingstone and Paleg (2014) further suggests that power mobility may be beneficial for children with multiple, severe disabilities even though these children may never become capable, community drivers. Additional research is needed to further explore power mobility training and use in this population.

References:

1. Durkin, J. (2009). Discovering powered mobility skills with children: ‘Responsive partners’ in learning. *International Journal of Therapy and Rehabilitation*, 16(6)331–341.
2. Fisher, W.W., Piazza, C.C., Bowman, L.G., & Amari, A. (1996). Integrating caregiver report with a systematic choice assessment to enhance reinforcer identification. *American Journal on Mental Retardation*, 101(1):15–25.
3. Kenyon, L.K., Farris, J., Cain, B., King, E.L., & VandenBerg, A. (2015). Development of a tool to aid clinicians in creating power mobility interventions. *Pediatric Physical Therapy*, 27:E33.
4. Kenyon, L.K., Farris, J., Brockway, K., Hannum, N., & Proctor K. (2015). Promoting self-exploration and function through an individualized power mobility training program. *Pediatric Physical Therapy*, 27(2):200–206.
5. Kenyon, L.K., Farris, J.P., Gallagher, C., Hammond, L., Webster, L.M., & Aldrich, N.J. (2016). Power mobility training for young children with multiple, severe impairments: a case series. *Physical and Occupational Therapy in Pediatrics*, 1–16. doi:10.3109/01942638.2015.1108380.
6. Livingstone, R., & Paleg, G. (2014). Practice considerations for the introduction and use of power mobility for children. *Developmental Medicine and Child Neurology*, 56(3):210–232.

-
7. Livingstone, R., & Field, D. (2014) Systematic review of power mobility outcomes for infants, children and adolescents with mobility limitations. *Clinical Rehabilitation*, 28(10):954-964.
 8. Nilsson, L.M., & Nyberg, P.J. (2003). Case report—driving to learn: a new concept for training children with profound cognitive disabilities in a powered wheelchair. *American Journal of Occupational Therapy*, 57(2):229-233.
 9. Nilsson, L., Nyberg, P., & Eklund, M. (2010). Training characteristics important for growing consciousness of joystick-use in people with profound cognitive disabilities. *International Journal of Therapy and Rehabilitation*, 17(11):588-595.
 10. Nilsson, L., Eklund, M., Nyberg, P., & Thulesius, H. (2011). Driving to learn in a powered wheelchair: the process of learning joystick use in people with profound cognitive disabilities. *American Journal of Occupational Therapy*, 65(6):652-660.

Please address correspondence:

to Dr. Kenyon at the following e-mail address: kenyonli@gvvsu.edu

We (**Lisa Kenyon and John Farris**) do not have any conflicts of interest to disclose. Specially, none of the authors have an affiliation (financial or otherwise) with an equipment, medical device, or communications organization.

IC31: Meeting Lifetime Mobility Needs of Spinal Cord Injury and Disease

Kara Murphy, MS, OTR/L
Amy Baxter PT, DPT, ATP

Abstract

Persons with spinal cord injury or spinal cord related disorders such as MS and ALS present with complex, often quickly changing seating and mobility needs. Working on a SCI/D unit within the Veteran's Health Administration, we are able to follow the individuals we serve through regular comprehensive multi-disciplinary evaluations. We will discuss changing mobility needs with progression of disorders and aging and planning for those changes to ensure our Veterans can stay in their homes.

Background

Persons with spinal cord injury or spinal cord related disorders (SCI/D) such as multiple sclerosis (MS) and amyotrophic lateral sclerosis (ALS) present with complex, often quickly changing seating and mobility needs. Meeting these needs requires a multidisciplinary team with regular follow-up and care coordination.

Objectives

1. Identify four positioning components to consider when providing mobility equipment to meet evolving long term needs for individuals with progressive diseases including multiple sclerosis and amyotrophic lateral sclerosis.
2. List three common functional changes related to aging with spinal cord injury and identify three related considerations for providing seating and positioning solutions.
3. Discuss three ways to meet mobility needs to enable veterans to (return to/stay in their home). (function independently in their home and community).

Evaluation and Positioning Considerations

- How will bowel and bladder needs be addressed – recline can make it significantly easier for a client or caregiver to perform straight cathing in the chair.
- How are they transferring now, how will they be transferring next.
- Will elevate or anterior tilt with elevate allow them greater independence for a longer period of time with stand pivot or slideboard transfers.
- Will the positioning features allow the caregiver be able to perform mechanical lift transfer easier, getting sling in/out.

- Edema control or use of elevating legrests to assist in repositioning – some clients are able to use elevating legrests with recline or tilt to reposition themselves in their chair.
- The wheelchair needs to be able to easily be adapted as the client progresses – extra supports can be added, alternative controls, seat depth growth.

Aging with Spinal Cord Injury

Approximately one in five people with SCI in the US are veterans with the majority having longstanding injuries (Curtain 2012). An older population also has more secondary health problems that must be taken into consideration.

Effects of aging with SCI:

- Musculoskeletal/Repetitive strain
- Skin integrity
- Bone density
- Cardiovascular
- Bowel/bladder

Considerations for Seating/Mobility With Progressive Disorders- Meeting Lifetime Needs

From the first time a patient with a progressive disease such as MS or ALS is evaluated, the seating and mobility specialist needs to begin planning for their seating and mobility needs months to years down the road. According to Findlayson (2014) 58.6% of patients with MS report the use of at least two mobility devices. It is important to ask about all devices a person uses not just the primary one. Often clients are limited by resources and are only able to meet some of their needs.

Just because the client in front of you can perform pressure relief, transfer independently, or walk short distances doesn't mean this will be the case by the time he/she is fitted with the wheelchair. When was the client diagnosed, how has their progression been up until now, what equipment are they currently using, how do they function throughout the entire day. Spending a couple hours in seating clinic isn't enough time to see your client's performance for an entire day. We need to be asking the right questions and leading the client/family/caregivers to describe the whole picture to ensure all areas of need are addressed.

Sometimes we need to ask the hard questions such as do they intend to get a feeding tube? Will they elect to use a ventilator? Despite the difficulty of these questions for anyone to discuss they are an integral part in a seating and mobility evaluation for these clients. What good is a wheelchair if the client is unable to use it once on a ventilator? Planning in advance we are able to meet the client's needs in the immediate future as well as years ahead with the possibility of longer periods of independence. This in turn decreases caregiver burden and enables client's to stay in their own homes.

Although all decisions do not need to be made at the initial evaluation, the clinician must plan for the possibility of the need to add additional equipment such as a ventilator, postural supports, or specialty controls in a timely manner.

References

1. Curtin, C. M., Suarez, P. A., Ponio, L. A., & Frayne, S. M. (2012). Who are the women and men in Veterans Health Administrations current spinal cord injury population? *The Journal of Rehabilitation Research and Development* JRRD, 49(3), 351. doi:10.1682/jrrd.2010.11.0220
2. Finlayson, M. L., Peterson, E. W., & Asano, M. (2013). A cross-sectional study examining multiple mobility device use and fall status among middle-aged and older adults with multiple sclerosis. *Disability and Rehabilitation: Assistive Technology*, 9(1), 12-16. doi:10.3109/17483107.2013.782578
3. Majmudar, S., Wu, J., & Paganoni, S. (2014). Rehabilitation in amyotrophic lateral sclerosis: Why it matters. *Muscle & Nerve*, 50(1), 4-13. doi:10.1002/mus.24202

IC32: An Introduction to Hybrid Alternative Driving Systems

Steven J. Mitchell, OTR/L, ATP

Alternative driving systems are often prescribed for users with SCI, ALS, and MS. Unfortunately, these systems frequently fail to provide the types of outcomes we want with these populations. It's not the technology that's the problem, it's how we implement it.

Hybrid Alternative Driving Systems (HADS) combine characteristics of more than one system to assign key functions to other points of control. HADS can be effective when a user lacks sufficient head control, oral motor function, or cognition to use any one system. This presentation will demonstrate how HADS can be a very practical way to achieve successful outcomes with some of our most challenging cases.

Learning Objectives:

Upon completion of this session, attendees will be able to;

- Identify three clinical reasons why many users with SCI, MS, or ALS have difficulty using alternative driving controls when they are provided in the manufacturer's standard configurations.
- Describe three clinical scenarios where the ability to combine characteristics of multiple systems would significantly improve the United Statesability of a switch activated driving control.
- List one advantage and disadvantage of using mechanical switches, proximity sensors, or a 2-function pneumatic switch in the configuration of a hybrid system.

References:

1. Cowan, R. E., Fregly, B. J., Boninger, M. L., Chan, L., Rodgers, M. M., & Reinkensmeyer, D. J. (2012). Recent trends in assistive technology for mobility. *Journal of NeuroEngineering and Rehabilitation*, 9(1), 20.
2. Westlund, E., Sponseller, K., Pettersson, O., & Bared, A. (2015). Evaluating gaze-driven power wheelchair with navigation support for persons with disabilities. *Journal of Rehabilitation Research and Development*, 52(7), 815-826.
3. Johnson, A. N., Huo, X., Ghovanloo, M., & Shinohara, M. (2012). Dual-task motor performance with a tongue-operated assistive technology compared with hand operations. *Journal of NeuroEngineering and Rehabilitation*, 9(1), 1.

PS4.1: Effects of Adjusting Wheelchair Configuration on Ramp Propulsion

Sarah Bass

Alicia Koontz, RET, ATP

Manual wheelchair setup is important for efficient wheelchair propulsion. When ascending ramps this set up makes the wheelchair more unstable leading to potentially harmful biomechanics. This presentation explores the differences in ramp propulsion biomechanics between four different manual wheelchair configurations, under testing conditions that include three inclines and two speeds.

Learning Objectives:

Upon completion of this session, attendees will be able to;

- List three features of wheelchair set up and their importance to propulsion biomechanics.
- For each of the four configurations tested in the study, list two differences in the biomechanics between them.
- Describe three community architectural features where having an adjustable footrest and seat position would benefit wheelchair users.

References:

1. Boninger, M. L., Waters, R. L., Chase, T., Dijkers, M. J., Gellman, H., Girona, R. J., . . . McDowell, S. (2005). Preservation of upper limb function following spinal cord injury: A clinical practice guideline for healthcare professionals. Consortium for Spinal Cord Medicine.
2. Chow, J. W., Millikan, T. A., Carlton, L. G., Chae, W., Lim, Y., & Morse, M. I. (2009). Kinematic and Electromyographic Analysis of Wheelchair Propulsion on Ramps of Different Slopes for Young Men With Paraplegia. *Archives of Physical Medicine and Rehabilitation*, 90(2), 271-278.
3. Mulroy, S. J., Newsam, C. J., Gutierrez, D. D., Requejo, P., Gronley, J. K., Haubert, L. L., & Perry, J. (2005). Effect of fore-aft seat position on shoulder demands during wheelchair propulsion: Part 1. A kinetic analysis. *Journal of Spinal Cord Injury*, 28, 214-221.

PS4.2: Montana Postural Care Project: A 24-Hour Postural Care Model

Tamara Kittelson-Aldred, MS, OTR/L, ATP/SMS

Background

24 hour postural care, also known as postural management, encompasses all activities which affect a person's posture and function. The approach has potential to benefit people of any age who have difficulty shifting position easily and frequently around the clock. This is done by supporting the person's body in a well-aligned, comfortable position, throughout the day and night. 24 hour postural care has been discussed and developed in the United Kingdom since the 1970s and 80s (Fulford and Brown, 1976; Hare, [ca.1984]). Today it is not difficult to find resources like therapy practice guides for 24 hour postural management published in the UK, Europe, Australia and New Zealand. In these places it is discussed and used with some regularity if not consistency in execution to maintain and improve range of motion, body shape and alignment, thus promoting health, reducing the risk of postural deformities, supporting motor development, and enhancing participation in daily life.

Postural management must be tailored specifically for an individual and addresses the three primary postural orientations in which we spend our lives: lying, sitting and standing. In order to be effective, a 24 hour postural care plan must be integrated into the lifestyle and daily routine of the user. This requires that families and caregivers be intimately involved in the process, so they are well versed in postural management principles and the process of implementing the unique intervention for their person. Clinical experience and evidence available suggests that training and empowerment of families, caregivers and professionals may support more successful outcomes (Bacon, 2013; Castle et al, 2014). Being able to make adaptations and resolve issues that arise without the presence of a professional is necessary when addressing posture day and night. There is much more involved than just provision of equipment.

Currently 24 hour postural care is not a typical approach in the United States. While seating systems and standing frames are commonly used, they address only two of the three primary postural orientations. Lying posture is often either ignored or not seen as a priority compared to daytime posture. Questions are sometimes raised about the safety of night-time positioning. When it is used, it is often as a last ditch effort for people with significant postural distortions and complex body shapes. Using supported lying posture as an integral part of prevention or limitation of scoliosis, pelvic rotation and obliquity and joint dislocations is not typically seen or discussed in the United States.

Clinically 24 hour postural management is recommended by Gericke (2006) and others such as Sunny Hill Children's

Hospital. It is logical to therapists despite a paucity of published high level studies. Night therapeutic positioning shares common theoretical ground with use of custom seating systems, bracing and equipment like standing frames that support a person's body in symmetry and midline orientation to the extent possible. Evidence suggests connections between asymmetrical positioning and postural deformities (Pope, 2007; Porter, 2008; Rodby-Bousquet, 2013), thus the value of therapeutic positioning can be extrapolated. Using it at night is a time when forces of gravity can be used in a positive way as a person rests, frequently with relaxed muscle tone during normal sleep patterns.

The Montana Postural Care Project is a pilot program funded by the Montana Council on Developmental Disabilities. The purpose is introduction of 24 hour postural care as a practical approach for people with motor impairments in a large rural state with limited special services, while examining the results in the population served. An affordable and non-invasive way to support the health and well-being of Montanans at risk for developing postural deformities is the goal.

Methods

The Montana Project was funded to work with 30 focus people throughout the state of Montana in its first year. Montana has five Developmental Disability Program (DDP) Regions; participation was to be evenly divided among them. Participants were recruited through announcements sent electronically to DDP case managers and providers, occupational and physical therapists, and parent support and training social media.

A secure online application process gathered demographic information, health and medical history, care team members, and specific questions related to posture and mobility, assistive technology and medical equipment and reasons why project participation was seen as valuable for the individual. Photographs of the applicant in unsupported supine lying, unsupported sitting (if possible) and supported sitting were uploaded as part of the process. While applicants were sought from all areas of the state, only four of the five DDP regions were represented in the applicant pool. Therefore the six extra spaces were divided among other regions where there were many interested and appropriate applicants.

A program was developed with several components:

- Training – Between March 9 and April 11, 2016, a one day training course was provided for focus people, their families/ caregivers, therapists and others closely involved with their care (personal care assistants, direct service professionals, nurses etc.). Occupational and physical therapists earned CEUs for their state licenses. Training courses were free of charge with lunch provided at a central location in each region. Funding to assist families with travel and childcare was available on a financial need basis.
- Consultation/assessment – the training day was followed by a half day in-home consultation for each individual, during which baseline measures were completed and recommendations made. The Goldsmith Indices of Body Symmetry (GloBS), the Pittsburgh Sleep Quality Index

(PSQI), Paediatric Pain Profile (PPP) or other pain scales when appropriate, and photographs in sitting and lying postures were used. A few individuals were also scored retrospectively using portions of the Posture and Posture Ability Scale (PPAS). Daytime positioning and mobility equipment was reviewed when available, often resulting in recommendations and referrals for replacement equipment. The Montana Project did not provide any daytime positioning equipment; occasionally wheelchair seating adjustments were made in order to make inappropriate seating tolerable for the person to use.

- Night postural care plan - Recommendations were made for supported lying postures to be used at night and other times when resting, with the goal of a safe, symmetrically supported therapeutic position. This often involved a gradual transition from side or prone sleeping that was inherently asymmetrical. Participants were provided with 4 basic postural supports: non-slip mesh, pressure relieving airflow mattress pad, lateral supports of two different styles according to individual needs and (in most but not all cases) a leg positioner to promote lower body alignment. Additional customization used household items like rolled towels, cushions and stuffed animals. An individualized report with photos for visual reference was provided to assist in implementation of the night-time positioning program.
- Ongoing support - Participants and their families were invited to contact Montana Project staff by telephone or email for support and problem solving as needed, in addition to local support available through the cohort that had gone through training together.
- Follow-up – Two phases of follow-up were planned:
 - Midterm – midway through the pilot project participants were asked to complete an online functional assessment questionnaire and the PSQI. Five partial and nine complete midterm assessments were received.
 - Final – Final follow-up occurred September 5-16, 2016. Participants were seen in person; baseline measures were repeated at this time, in addition to the functional assessment questionnaire provided at mid-term and a project evaluation.

Findings

Of the original 30 participants, 26 were seen for final follow-up visits. Two participants had reported positive anecdotal results but moved away before follow-up was done. One participant died and another disappeared without communication. Of the 26 participants remaining, four did not implement the postural care program for various reasons. Three did not complete the anecdotal assessment form although all outcome measures were done. Several people were able to tolerate full measurement procedures at final follow-up that were previously intolerable because of discomfort, tone or spasticity; this suggested positive change.

There were positive results within 5-6 months of beginning interventions, based on the measures used, with improvement in body symmetry, sleep quality and reduction of pain. Of those who implemented night postural management even part-time, nearly 80% experienced improved sleep quality and more than 80% showed improvement in some aspect of body symmetry. More than 50% of those for whom pain was an issue exhibited lower pain scale scores. In no case was improvement seen in any area for those who did not implement night postural care.

Chart 1 – Sleep changes

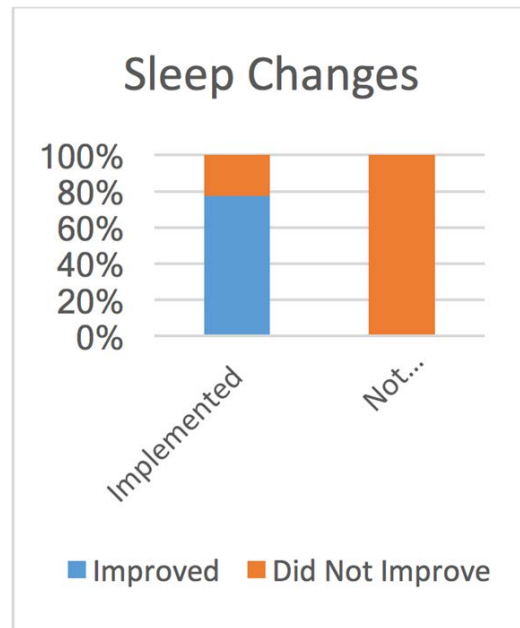

Bar graph showing almost 80% had improvement in sleep quality among those who implemented night postural care, with 0% sleep improvement in those who did not.

Chart 2 – Body symmetry changes

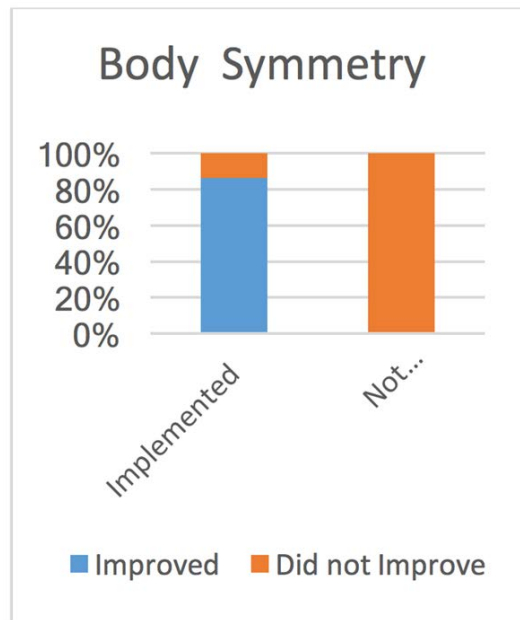

Bar graph showing more than 80% had improvement in body symmetry among those who implemented night postural care, with 0% body symmetry improvement in those who did not.

Chart 3 – Pain changes

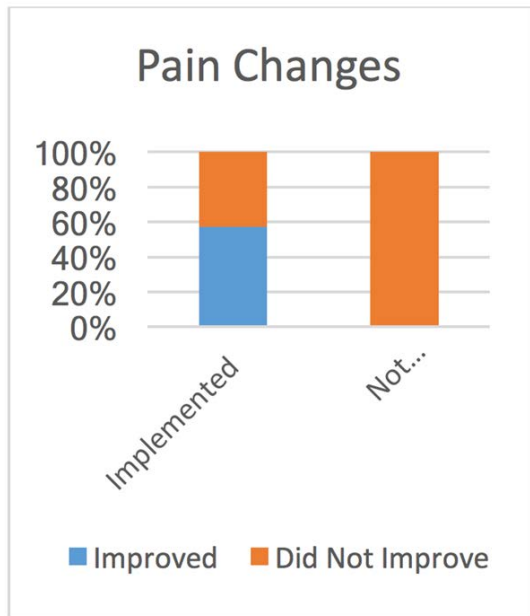

Bar graph showing more than 50% experienced pain reduction among those who implemented night postural care, with 0% body symmetry improvement in those who did not.

Twenty of the focus people and their families who completed follow-up rated the training and information as “very helpful”; the rest either did not complete the assessment or missed answering the question. Daytime alertness was the most commonly reported positive change anecdotally, followed by improved lying and sitting posture. In no case had any participant received new or updated daytime equipment since project inception; for most people the only major change in their routine was the addition of night postural care to their routine. The anecdotal reports are consistent with the outcome measures.

Discussion

Participants - The Montana Postural Care Project is a training and service based pilot program. It is not a formal research study, therefore these results should be interpreted in that light. Participants were volunteers who already had postural distortions, in some cases severe; they and/or their families and caregivers wanted to learn about and try 24 hour postural care as a helpful approach. Some had experienced failed spinal fusion instrumentation or were deemed too fragile for spinal surgery. Families of participants often had a strong desire to avoid or postpone surgery and were committed to work toward that goal. Strong family involvement appeared related to positive outcomes.

Outcome measures - The PSQI was used for all participants regardless of age; while it has been used in children with various conditions several times over the years, it was normed for adults in a psychiatric context (Buysse et al, 1989). The psychometric properties of the GloBS are limited, with chest symmetry measurements as yet untested. A 1992 study to test validity and interrater reliability of the

Goldsmith windswept index suggested it has clinical value when used by trained measurers (Goldsmith et al). In the Montana Project these measurements were done by a trained measurer. Moreover it should be noted that goniometry and linear measurements are frequently used to measure therapy outcomes clinically, and the specific protocol of the GloBS may offer enhanced value. The PPP is designed for use with non-verbal children with disabilities; in the Montana Project this pain profile was also used with non-verbal adults where pain was deemed to be a problem. Those who were able used more standard pain scales. Finally, the mid-term and final assessment form was not a formal, tested tool; it was created based on areas of improvement previously reported in people who added night postural management to their routine. It was intended to gather anecdotal reports of changes that were of value to families and caregivers but would not otherwise be recorded.

Conclusion

This paper outlines the development of a pilot 24 hour postural care program. Encouraging results were seen in 6 months or less with respect to improvement of body symmetry and sleep quality, and reduction in pain. Anecdotal feedback from families and caregivers suggested positive results consistent with testing, in addition to other improvements in individuals otherwise not measured. These results should be interpreted with caution as the project is not a formal research study, and the measures used have psychometric limitations. However in light of positive feedback shared by families and caregivers and the improvements documented, the value of using postural supports in lying at night and during daytime rests should be explored further.

References

1. Bacon, H. (2013) Does a Postural Management Training Programme Improve Understanding of the Importance of Postural Management for Children with Complex Movement Disorders? *APCP*, 4 (1), 27-36.
2. Buysse D, Reynolds C, Monk T, Berman SR, & Kupfer D. (1989) The Pittsburgh Sleep Quality Index: a new instrument for psychiatric practice and research. *Psychiatry Res.* 28 (2), 193-213
3. Castle, D., Stubbs, B., Clayton, S., & Soundy, A. (2014). A 24-hour postural care service: Views, understanding and training needs of referring multidisciplinary staff. *International Journal of Therapy and Rehabilitation*, 21(3), 132-139.
4. Cobb, J., Giraud-Saunders, A. (2010) Commentary on Biomechanics and prevention of body shape distortion. *Tizard Learning Disability Review*, 15 (2), 30-32.
5. Gericke, T. (2006). Postural management for children with cerebral palsy: Consensus statement. *Developmental Medicine & Child Neurology*, 48(04), 244.
6. Goldsmith L, Golding RM, Garstang RA & Macrae AW (1992) “A technique to measure windswept deformity.” *Physiotherapy*, 78 (4), 235–42.
7. Goldsmith Indices of Body Symmetry. <http://www.simplestuffworks.co.uk/downloads>. Accessed November 2016.

-
8. Hare Association for Physical Ability. (2007) <http://www.hafpa.info>. Accessed November 2016.
 9. Pope, P. (2007) "Severe and Complex Neurological Disability: Management of the Physical Condition". Butterworth-Heinemann Publishers.
 10. "Positioning for Children GMFCS Levels IV-V: Focus on Hip Health" BC Children's Hospital. <http://www.childdevelopment.ca/GMFCSHipHealth/GMFCSHipHealthIntroduction.aspx>. Accessed November 2016.
 11. Porter D, Michael S, Kirkwood C. (2008) "Is there a relationship between preferred posture and positioning in early life and the direction of subsequent asymmetrical postural deformity in non-ambulant people with cerebral palsy?" Child Care Health Development, Vol. 34, pages 635–41.
 12. Rodby-Bousquet, E, Czuba, T, Hägglund, G and Westbom, L. "Postural asymmetries in young adults with cerebral palsy." (2013) Developmental Medicine & Child Neurology, Vol. 55, pages 1009–1015.

PS4.3: Adverse Consequences From Wheelchair Breakdowns and Increased Risk of Hospitalization

Nathan S Hogaboom

Lynn A Worobey, PhD

Michael L Boninger, PhD

This material is the result of work supported with resources and the use of facilities at the Human Engineering Research Laboratories, VA Pittsburgh Healthcare System. The contents of this paper do not represent the views of the Department of Veterans Affairs or the United States Government. The contents of this paper were developed under a grant from the National Institute on Disability, Independent Living, and Rehabilitation Research (NIDILRR grant number 90SI5008). NIDILRR is a Center within the Administration for Community Living (ACL), Department of Health and Human Services (HHS). The contents of this (insert type of publication; e.g., book, report, film) do not necessarily represent the policy of NIDILRR, ACL, HHS, and you should not assume endorsement by the Federal Government. This material is based upon work supported by the National Science Foundation Graduate Research Fellowship (grant #1247842). The contents of this publication do not necessarily reflect the view of the National Science Foundation or the policy of NIDILRR, ACL, HHS, and you should not assume endorsement by the Federal Government.

INTRODUCTION

Receipt of a spinal cord injury (SCI) has a profound impact on an individual's life. Barriers emerge that make it more difficult to achieve full independence and participation. An individual with an SCI is susceptible to many secondary complications that result from the injury itself. The inability to effectively manage pressure can result in a pressure ulcer, which can negatively impact physical and psychological health (Fuhrer, Garber, Rintala, Clearman, & Hart, 1993; Gorecki et al., 2009; Guidelines, 2001; J. S. Krause, 1998; Richards, Waites, Chen, Kogos, & Schmitt, 2004). Hospitalizations are common, with approximately 30% of individuals being re-hospitalized within the first year post-injury; diseases of the genitourinary system and skin are the two most common reasons. Although this rate decreases as time since injury increases, these complications can have profound effects on quality of life (Budh & Osteraker, 2007; Charlifue, Lammertse, & Adkins, 2004; Leduc & Lepage, 2002; Putzke, Richards, Hicken, & DeVivo, 2002).

For those who do not regain the ability to ambulate, many must rely on the use of a wheelchair for full participation. Previous literature suggests providing an individual with the skills necessary to utilize their device can improve independence and prevent musculoskeletal injuries (Hosseini, Oyster, Kirby, Harrington, & Boninger, 2012; J. Krause,

Carter, & Brotherton, 2009). A properly-fitted wheelchair also optimizes pressure and postural alignment to minimize pain and seating discomfort (Hastings, Fanucchi, & Burns, 2003; Hobson, 1992; Hobson & Tooms, 1992; Regan et al., 2009; Samuelsson, Larsson, Thyberg, & Gerdle, 2001; Shields & Cook, 1992). However, it is cited as one of the most limiting factors to participation, more so than other health- and non-health- related barriers (Chaves et al., 2004). If a component breaks and is not immediately repaired, the individual could be stranded, injured, or prevented from participating in activities (Hansen, Tresse, & Gunnarsson, 2004; McClure et al., 2009; L. Worobey, Oyster, Nemunaitis, Cooper, & Boninger, 2012). Previous reports indicate about half of wheelchair users with SCI experience a breakdown, and between 20% and 30% an adverse consequence (McClure et al., 2009; L. Worobey et al., 2012).

The wheelchair one of the primary means of managing secondary conditions for a person with an SCI; thus, the inability to fully use the device may put the user at risk of worsening these conditions. While other groups have identified risk factors for pressure ulcers and hospitalizations, none have incorporated the wheelchair in their investigations (Cardenas, Bryce, Shem, Richards, & Elhefni, 2004; Cardenas, Hoffman, Kirshblum, & McKinley, 2004; Chen, Devivo, & Jackson, 2005; Turner, Cardenas, Warm, & McClellan, 2001). The objective of this study was to evaluate the relationship between wheelchair repairs, consequences of those breakdowns, and secondary conditions in a sample of wheelchair users with SCI. Participants who reported needing wheelchair repairs, and experiencing consequences from those breakdowns, were hypothesized to have higher odds of hospitalization related to skin disease.

METHODS

Subjects

Participants were enrolled if they were older than 16 years, had neurologic impairment resulting from a SCI that occurred at least 1 year prior to the study, were treated at a national SCI Model Systems site, and used a manual- and power-wheelchair (including power assisted manual chairs) over 40 hours per week.

Data Collection

Data were collected between 2011 and 2016 as part of the SCIMS centers in the following cities: Boston, MA (2 sites: Boston Medical Center, Spaulding); Chicago, IL; Louisville, KY; Philadelphia, PA; Pittsburgh, PA; Washington, DC; West Orange, NJ; Seattle, WA. Each center was responsible for recruitment and enrollment at their center. Recruitment methods included approaching individuals who participated in the National SCI Database, local registries, flyers, and identification by clinical staff. Surveys were completed during interviews, over the phone, or via mail. All centers obtained ethical approval from their local institutional review boards. Participants completed a questionnaire that inquired about demographic information and secondary conditions. Demographic factors included age, sex, race, employment and marital status, injury level, and insurance coverage. Participants were asked how many repairs were needed to their wheelchairs within the past 6 months, and whether any consequences occurred as a result of those breakdowns; responses included no consequence, missing a medical appointment, missing work or school, being stranded, or

being injured (McClure et al., 2009). They were also asked whether they received a repair for their broken component or have a working backup wheelchair. Participants provided information about the number of days hospitalized over the past 12 months, and one of 18 reasons for those hospitalizations; specific reasons are highlighted in previous literature (Cardenas, Hoffman, et al., 2004). Of interest in the present study were those who reported a hospitalization from diseases of the skin/subcutaneous tissue (including pressure ulcers).

Data Reduction and Analysis

All statistical analyses were performed using SPSS 23.0 (IBM, Inc., Armonk, New York, USA). Significance was set a priori to $\alpha=.05$. Descriptive statistics were first calculated, including means and standard deviations for continuous variables and frequencies for nominal variables. Demographic variables were recoded to optimize cell size, in accordance with previous studies investigating wheelchair consequences or hospitalizations (Cardenas, Hoffman, et al., 2004; McClure et al., 2009; L. Worobey et al., 2012): injury level into tetraplegia or paraplegia; race into minority or white; education into high school diploma or less, or post-high school education; marital status into married/living with partner, never married, or divorced/separated/widowed/other; employment status into employed, unemployed, or homemaker/on-the-job-training/retired/student/other; and insurance payer into private, Medicare, Medicaid, or other. Participants were placed into three groups depending on whether they reported 1) no repairs or consequences, 2) at least one repair but no consequences, or 3) at least one repair with consequences. Hospitalizations were recoded into no hospitalizations, hospitalized at least once for reasons unrelated to skin disease, or hospitalized at least once specifically from skin disease. Sex was not transformed (male or female).

Table 1. Descriptive statistics of demographics and consequences for intact and missing datasets, and between-groups analyses. Continuous variables are presented as frequencies (percentages) and continuous variables as means (standard deviations).

		Intact (N=620)	Missing	Missing N
Age		44.1 (13.8)	44.9 (15.1)	148
Race	White	471 (76.0)	108 (76.6)	141
	Minority	149 (24.0)	33 (23.4)	
Sex	Male	499 (80.5)	115 (76.7)	150
	Female	121 (19.5)	35 (23.3)	
Marital	Married/Living with Partner	222 (35.8)	51 (33.8)	151
	Single	276 (44.5)	71 (47.0)	
	Other	122 (19.7)	29 (19.2)	
Education	>HS	280 (45.2)	64 (42.7)	150
	HS or less	340 (54.8)	86 (57.3)	
Injury Level	Paraplegia	337 (54.4)	66 (49.3)	134
	Tetraplegia	283 (45.6)	68 (50.7)	
Employment*	Employed	163 (26.3)	40 (27.0)	148
	Unemployed**	260 (41.9)	40 (27.0)	
	Other**	197 (31.8)	73 (45.9)	
Consequences	None	260 (41.9)	36 (35.6)	101
	Repairs with no consequences	248 (40.0)	45 (44.6)	
	Repairs and consequences	112 (18.1)	20 (19.8)	

Notes. The Missing N column denotes how many participants had missing data for each independent variable.
* Significant chi-square test, $\chi^2(2, N = 768) = 13.78, p < .01, V = .15$

Participants were eliminated from the analysis if they did not report demographics, repairs, or hospitalizations. In this way, the same cohort of individuals could be compared across the different outcome measures. Potential bias from this

additional exclusion was investigated using chi-square tests for nominal variables and independent t-tests for continuous variables (excluded versus included).

Logistic regression models tested whether repairs and consequences increased odds of self-reported pressure sore development or hospitalizations related and unrelated to skin breakdown. Demographic variables were input as predictors: age, sex referenced to male, race referenced to white, injury level referenced to paraplegia, education referenced to post-high school degree, marital status referenced to married/living with partner, employment referenced status to employed, and insurance payer referenced to private. Repairs/consequences was referenced to the group without repairs or consequences. Hospitalizations were both referenced to the groups who reported none.

RESULTS

Subjects

Table 2. Descriptive and chi-square analysis of Component failures in participants who experienced a breakdown, grouped by those with and without adverse consequences. Data are presented as frequencies (percentages).

Component	Failed?	No Cons.	Cons.
Electrical System*	No	57 (69.5)	15 (31.9)
	Yes	25 (30.5)	32 (68.1)
Power Control System†	No	56 (66.7)	16 (42.1)
	Yes	28 (33.3)	22 (57.9)
Peripheral Component§	No	58 (61.7)	13 (31.7)
	Yes	36 (38.3)	28 (68.3)
Seating System	No	53 (54.1)	11 (29.7)
	Yes	45 (45.9)	26 (70.3)
User Interfaces	No	48 (43.6)	14 (33.3)
	Yes	62 (56.4)	28 (66.7)
Wheelchair Frame	No	62 (86.1)	18 (72.0)
	Yes	10 (13.9)	7 (28.0)
Wheels and Casters	No	30 (20.5)	7 (11.3)
	Yes	114 (79.5)	55 (88.7)

* $\chi^2(1, N=129) = 17.124, V = .36, p < .001$

† $\chi^2(1, N=122) = 6.526, V = .23, p < .05$

§ $\chi^2(1, N=135) = 10.301, V = .29, p < .01$

The data set consisted of 771 full-time wheelchair users with SCI; 151 had missing data and had to be excluded from the analysis. Demographic and repairs variables used in regression models are presented in Table 1. Participants with missing data were more often unemployed and less often in the “other” employment group ($p < .01$, Table 1). They more often reported hospitalizations unrelated to pressure sores, and less often reported no hospitalizations ($p < .05$, Table 2). No other differences were found.

In the current sample, 237 (38.2%) used a power chair, 361 (58.7%) a manual wheelchair, 16 (2.6%) a power-assisted manual chair, and 4 (0.3%) a scooter. Over half (58.1%) reported needing a repair, with 112 of these individuals reporting at least one adverse consequence (Table 1). The most common consequence was being stranded (12.1%), followed by missing a medical appointment (6.9%), missing work/school (3.5%), and being injured (2.9%). Only 21 (3.5%) subjects reported receiving a repair for a broken component. Failures of the electrical system, power control system, peripheral components, and seating system were associated with adverse consequences ($p < .05$, Table 2).

Hospitalizations

Over 35% of participants reported at least one hospitalization within the past year (Table 3). Results of the logistic regression models found no relationship between hospitalization and repairs without consequences ($p > .05$). Those who experienced consequences from their breakdowns had significantly higher odds of hospitalization unrelated to skin disease (OR: 1.9, 95%CI: 1.1-3.1, $p < .05$). These individuals also had higher odds of hospitalization related to skin disease, the but relationship only trended toward significance (OR: 2.2, 95%CI: 0.9-5.1, $p < .10$). Cervical-level injuries (OR: 1.66, 95%CI: 1.1-2.3, $p < .05$) and being in the "other" employment group (OR: 2.5, 95%CI: 1.4-4.2, $p < .01$) also were associated with higher odds of hospitalization unrelated to skin disease. No other variables were associated with hospitalizations.

Table 3. Descriptive statistics for hospitalizations between intact and missing datasets, and chi-square. Variables are presented as frequencies (percentages).

Hospitalizations*		Intact (N=620)	Missing (N=74)
		None**	390 (62.9)
	Unrelated to PU**	180 (29.0)	33 (44.6)
	Related to PU	50 (8.1)	4 (5.4)

* Significant chi-square test, $X^2(2, N = 694) = 7.606, p < .05, V = .10$

** Significant post hoc analysis with Bonferroni correction ($p < .05$)

DISCUSSION

The present study advanced previous knowledge about wheelchair breakdowns and their consequences by establishing a connection with hospitalizations. In accordance with hypotheses, participants who reported being stranded, missing a medical appointment or work/school, or being injured as a result of a wheelchair breakdown also had higher odds of hospitalizations related and unrelated to skin breakdown. This observation was not found in those who experienced breakdowns that were not serious enough to elicit an adverse consequence.

One of the most interesting findings of this study was that, when factoring out those who experienced adverse consequences, repairs themselves did not affect outcomes. Breakdowns that were serious enough to result in a negative consequence appeared to have this effect, despite only a small portion of these individuals receiving a repair for a broken component and no differences in backup chairs being observed. Breakdowns of electrical, seating, power, and control systems, and peripheral components (Table 2) were cited most commonly by those who experienced adverse consequences. A serious breakdown could relegate an individual to an inappropriate seating surface, such as a couch or bed, while minor repairs still allow the individual continued use of their device. More severe breakdowns could also prevent the user from utilizing the seating functions and postural supports necessary to manage their secondary conditions. It is difficult to prove these assertions, however, due to the high percentage of missing data regarding component breakdowns.

The findings in the present study reflect previous literature. Three studies that analyzed SCI Model Systems data found between 44% and 64% of their samples reported needing at least one repair. However, adverse consequence rates were much lower than the present study (between 19.7% and 30.5% of those reporting more than one repair compared to

44.9% in the present study). Differences could be attributed to analysis techniques and exclusion criteria, as well as changes over time in repair rates as indicated by Worobey, et al. (2012). Also in contrast to other previous works that utilized the SCI Model Systems database, employment and injury level were found to influence hospitalizations. (Cardenas, Hoffman, et al., 2004; Chen et al., 2005; McKinley, Jackson, Cardenas, & DeVivo, 1999). The present study utilized self-report measures in place of physician documentation (Chen et al., 2005; McKinley et al., 1999) and included only wheelchair users (Cardenas, Hoffman, et al., 2004; Chen et al., 2005; McKinley et al., 1999). Inclusion of wheelchair use in future investigations may garner a more complete depiction of factors related to hospitalization and pressure ulcer development.

In many cases, repairs are the result of factors outside of the user's control. Wheelchair type (i.e. manual versus power) and manufacturer appear to influence repair rates more than wheelchair age or usage (Fitzgerald, Cooper, Boninger, & Rentschler, 2001; McClure et al., 2009; Rentschler et al., 2004;

Toro, Worobey, Boninger, Cooper, & Pearlman, 2016; L. Worobey et al., 2012; L. Worobey, Oyster, Pearlman, Gebrosky, & Boninger, 2014).

Aside from shifts in manufacturing practices, providing the users with training to maintain their own chairs

may be a cost effective way to prevent breakdowns and, ultimately, negative health consequences. Many clinicians are unfamiliar with how to identify and rectify broken wheelchair components (Lynn Worobey, Pearlman, Dyson-Hudson, & Boninger, 2016); training in this area may also help prevent breakdowns and any health-related complications.

The nature of this study was exploratory and cross-sectional; it is difficult to say conclusively that the breakdown/consequence caused the secondary conditions to worsen. Health-promoting or self-destructive behaviors were not analyzed; these factors are associated with health status and pressure ulcer development and may also affect how proactive an individual is when maintaining their chair (J. S. Krause, Vines, Farley, Sniezek, & Coker, 2001). Participants were asked whether or not they experienced one of the listed consequences. One important piece of information that is missing is the number or frequency of the consequences that occurred. However, the significance associated with at least one is enough to warrant concern. It is likely that more adverse consequences amplify these relationships, yet this remains to be tested. Participants in the present study were treated at Model Centers on SCI and thus may not be generalizable to the entire SCI population. Considering the level of care provided at these centers, it is possible that outcomes are worse in less-resourced locations.

CONCLUSIONS

In a sample of wheelchair users with SCI, adverse consequences from wheelchair breakdowns were associated with hospitalizations related and unrelated to skin breakdown. Limiting these breakdowns, or intervening early enough to prevent an adverse consequence, may be an additional strategy in preserving the quality of life of these individuals. Wheelchair-related factors appear to impact quality of life in many ways and should be considered in future investigations with similar research objectives.

REFERENCES

1. Budh, C. N., & Osteraker, A. L. (2007). Life satisfaction in individuals with a spinal cord injury and pain. *Clin Rehabil*, 21(1), 89-96. doi:10.1177/0269215506070313
2. Cardenas, D. D., Bryce, T. N., Shem, K., Richards, J. S., & Elhefni, H. (2004). Gender and minority differences in the pain experience of people with spinal cord injury. *Arch Phys Med Rehabil*, 85(11), 1774-1781.
3. Cardenas, D. D., Hoffman, J. M., Kirshblum, S., & McKinley, W. (2004). Etiology and incidence of rehospitalization after traumatic spinal cord injury: a multicenter analysis. *Arch Phys Med Rehabil*, 85(11), 1757-1763.
4. Charlifue, S., Lammertse, D. P., & Adkins, R. H. (2004). Aging with spinal cord injury: changes in selected health indices and life satisfaction. *Arch Phys Med Rehabil*, 85(11), 1848-1853.
5. Chaves, E. S., Boninger, M. L., Cooper, R., Fitzgerald, S. G., Gray, D. B., & Cooper, R. A. (2004). Assessing the influence of wheelchair technology on perception of participation in spinal cord injury. *Arch Phys Med Rehabil*, 85(11), 1854-1858.
6. Chen, Y., Devivo, M. J., & Jackson, A. B. (2005). Pressure ulcer prevalence in people with spinal cord injury: age-period-duration effects. *Arch Phys Med Rehabil*, 86(6), 1208-1213. doi:10.1016/j.apmr.2004.12.023
7. Fitzgerald, S. G., Cooper, R. A., Boninger, M. L., & Rentschler, A. J. (2001). Comparison of fatigue life for 3 types of manual wheelchairs. *Arch Phys Med Rehabil*, 82(10), 1484-1488. doi:10.1053/apmr.2001.26139
8. Fuhrer, M. J., Garber, S. L., Rintala, D. H., Clearman, R., & Hart, K. A. (1993). Pressure ulcers in community-resident persons with spinal cord injury: prevalence and risk factors. *Arch Phys Med Rehabil*, 74(11), 1172-1177.
9. Gorecki, C., Brown, J. M., Nelson, E. A., Briggs, M., Schoonhoven, L., Dealey, C., . . . Nixon, J. (2009). Impact of pressure ulcers on quality of life in older patients: a systematic review. *J Am Geriatr Soc*, 57(7), 1175-1183. doi:10.1111/j.1532-5415.2009.02307.x
10. Guidelines, C. f. S. C. M. C. P. (2001). Pressure ulcer prevention and treatment following spinal cord injury: a clinical practice guideline for health-care professionals. *J Spinal Cord Med*, 24 Suppl 1, S40-101.
11. Hansen, R., Tresse, S., & Gunnarsson, R. K. (2004). Fewer accidents and better maintenance with active wheelchair check-ups: a randomized controlled clinical trial. *Clin Rehabil*, 18(6), 631-639.
12. Hastings, J. D., Fanucchi, E. R., & Burns, S. P. (2003). Wheelchair configuration and postural alignment in persons with spinal cord injury. *Arch Phys Med Rehabil*, 84(4), 528-534. doi:10.1053/apmr.2003.50036
13. Hobson, D. A. (1992). Comparative effects of posture on pressure and shear at the body-seat interface. *J Rehabil Res Dev*, 29(4), 21-31.
14. Hobson, D. A., & Tooms, R. E. (1992). Seated lumbar/pelvic alignment. A comparison between spinal cord-injured and noninjured groups. *Spine (Phila Pa 1976)*, 17(3), 293-298.
15. Hosseini, S. M., Oyster, M. L., Kirby, R. L., Harrington, A. L., & Boninger, M. L. (2012). Manual Wheelchair Skills Capacity Predicts Quality of Life and Community Integration in Persons With Spinal Cord Injury. *Arch Phys Med Rehabil*, 93(12), 2237-2243. doi:http://dx.doi.org/10.1016/j.apmr.2012.05.021
16. Krause, J., Carter, R. E., & Brotherton, S. (2009). Association of mode of locomotion and independence in locomotion with long-term outcomes after spinal cord injury. *J Spinal Cord Med*, 32(3), 237-248.
17. Krause, J. S. (1998). Skin sores after spinal cord injury: relationship to life adjustment. *Spinal Cord*, 36(1), 51-56.
18. Krause, J. S., Vines, C. L., Farley, T. L., Snieszek, J., & Coker, J. (2001). An exploratory study of pressure ulcers after spinal cord injury: relationship to protective behaviors and risk factors. *Arch Phys Med Rehabil*, 82(1), 107-113. doi:10.1053/apmr.2001.18050
19. Leduc, B. E., & Lepage, Y. (2002). Health-related quality of life after spinal cord injury. *Disabil Rehabil*, 24(4), 196-202.
20. McClure, L. A., Boninger, M. L., Oyster, M. L., Williams, S., Houlihan, B., Lieberman, J. A., & Cooper, R. A. (2009). Wheelchair repairs, breakdown, and adverse consequences for people with traumatic spinal cord injury. *Arch Phys Med Rehabil*, 90(12), 2034-2038. doi:10.1016/j.apmr.2009.07.020
21. McKinley, W. O., Jackson, A. B., Cardenas, D. D., & DeVivo, M. J. (1999). Long-term medical complications after traumatic spinal cord injury: a regional model systems analysis. *Arch Phys Med Rehabil*, 80(11), 1402-1410.
22. Putzke, J. D., Richards, J. S., Hicken, B. L., & DeVivo, M. J. (2002). Interference due to pain following spinal cord injury: important predictors and impact on quality of life. *Pain*, 100(3), 231-242.
23. Regan, M. A., Teasell, R. W., Wolfe, D. L., Keast, D., Mortenson, W. B., & Aubut, J. A. (2009). A systematic review of therapeutic interventions for pressure ulcers after spinal cord injury. *Arch Phys Med Rehabil*, 90(2), 213-231. doi:10.1016/j.apmr.2008.08.212
24. Rentschler, A. J., Cooper, R. A., Fitzgerald, S. G., Boninger, M. L., Guo, S., Ammer, W. A., . . . Algood, D. (2004). Evaluation of selected electric-powered wheelchairs using the ANSI/RESNA standards. *Arch Phys Med Rehabil*, 85(4), 611-619.
25. Richards, S., Waites, K., Chen, Y., Kogos, S., & Schmitt, M. M. (2004). The Epidemiology of Secondary Conditions Following Spinal Cord Injury. *Topics in Spinal Cord Injury Rehabilitation*, 10(1), 15-29. doi:10.1310/YXM3-85YW-8VUG-NNUR
26. Samuelsson, K., Larsson, H., Thyberg, M., & Gerdle, B. (2001). Wheelchair seating intervention. Results from a client-centred approach. *Disabil Rehabil*, 23(15), 677-682.
27. Shields, R. K., & Cook, T. M. (1992). Lumbar support thickness: effect on seated buttock pressure in individuals with and without spinal cord injury. *Phys Ther*, 72(3), 218-226.
28. Toro, M. L., Worobey, L., Boninger, M. L., Cooper, R. A., & Pearlman, J. (2016). Type and Frequency of Reported Wheelchair Repairs and Related Adverse Consequences Among People With Spinal Cord Injury. *Arch Phys Med Rehabil*. doi:10.1016/j.apmr.2016.03.032
29. Turner, J. A., Cardenas, D. D., Warms, C. A., & McClellan, C. B. (2001). Chronic pain associated with spinal cord injuries: a community survey. *Arch Phys Med Rehabil*, 82(4), 501-509. doi:10.1053/apmr.2001.21855
30. Worobey, L., Oyster, M., Nemunaitis, G., Cooper, R., & Boninger, M. L. (2012). Increases in wheelchair breakdowns, repairs, and adverse consequences for people with traumatic spinal cord injury. *Am J Phys Med Rehabil*, 91(6), 463-469. doi:10.1097/PHM.0b013e31825ab5ec
31. Worobey, L., Oyster, M., Pearlman, J., Gebrosky, B., & Boninger, M. L. (2014). Differences between manufacturers in reported power wheelchair repairs and adverse consequences among people with spinal cord injury. *Arch Phys Med Rehabil*, 95(4), 597-603. doi:10.1016/j.apmr.2013.11.022
32. Worobey, L., Pearlman, J., Dyson-Hudson, T., & Boninger, M. (2016). Clinician Competency with Wheelchair Maintenance and the Efficacy of a Wheelchair Maintenance Training Program. *Arch Phys Med Rehabil*, 97(10), e55. doi:http://dx.doi.org/10.1016/j.apmr.2016.08.165

PS4.4: An Ergonomic Comparison of Three Different Seated Transport Devices

Jefferson Griscavage

Sarah Bass

Jonathan Slowik, PhD

Alicia Koontz, PhD, RET

Learning Objectives:

- List three injury trends and risks for caregivers who perform transport tasks in hospitals and clinics.
- Be able to compare and list three differences between the different seated transport devices used in the study and how they may impact operators.
- Be able to explain three differences observed in operator trunk and upper extremity biomechanics and muscle demands as a direct result of specific features of the seated transport devices.

Introduction

Healthcare professionals rely heavily on seated transport devices to move patients in clinical settings. Traditionally, an emphasis has been placed on designing transport devices that maximize patient comfort and minimize purchase costs; however, little attention has been given to design concepts considering caregiver ease of use and safety (Lee, 2013). Epidemiological studies have found that work-related musculoskeletal injuries are particularly prevalent in the healthcare profession (Oranye, 2016). Specifically, these injuries occur at the highest incidence in caregivers who manually handle patients (Kothiyal, 2004) or spend greater than 2 hours per day performing pushing/pulling tasks (Oranye, 2016). Among reported injuries lumbar pain is the most frequent, followed by upper extremity strains and sprains (Daikoku, 2008).

Caregiver injury has far-reaching implications beyond the associated individual pain and suffering. The nursing profession has the second highest occupational rate of overexertion injuries that require days away from work (Wunderlich, 1996). This has a significant impact on hospital staffing levels, dramatic financial implications for organizations, and ultimately is a barrier to patient outcomes.

To date, few studies have investigated the direct impact of seated transport device design on operator musculoskeletal burden. What data exists suggests that the generally lower

and nonadjustable handlebars of standard transport devices in hospitals today are ergonomically inadequate in meeting operator demands, and may be a contributing factor to work-place injury.

One potential method to mitigating incidence of caregiver musculoskeletal injury is through ergonomic optimization of seated transport device design. A seated transport device, Stryker® Prime TC (PTC), has recently been developed specifically to minimize caregiver strain during patient transport in clinical settings. Ergonomic features specific to the PTC include: vertically oriented push handles that accommodate caregivers of varying heights, adjustable armrests and footrests for ease in patient ingress/egress, a one-touch central brake pedal that eliminates bending when initiating wheel locks, and rigid and highly maneuverable frames with anti-tip wheels. These features seek to reduce awkward motions and forces on caregivers by facilitating more natural postures and favorable joint angles during pushing tasks.

The purpose of this study was to compare differences in operator trunk and upper extremity muscle activity and joint angles when operating the ergonomically designed Stryker® Prime TC (PTC) and two other seated transport devices: a Breezy® Ultra 4 Wheelchair (STC) and a Staxi® Medical Chair (SXM). It was hypothesized that caregivers would demonstrate less muscle activation and more favorable joint angles for the ergonomically designed PTC as compared to the standard STC and commercially available SXM.

Methods

Subjects:

Twenty-two healthcare professionals with patient transport experience were recruited to participate in the study and all provided their informed consent. Recruitment and data collection took place at the Human Engineering Research Laboratory from December 2015-July 2016.

Experimental Protocol:

Subjects performed tasks designed to reflect routine clinical work-related transport duties of caregivers. Each device was loaded with a test dummy weighing 185 pounds. The three seated transport devices utilized in this study are shown in Figure 1.



Figure 1: A) Stryker® Prime TC Chair, B) Staxi® Medical Chair, C) Breezy® Ultra 4 Wheelchair

Subjects were outfitted with electromyography (EMG) surface electrodes placed on eight muscle groups bilaterally (erector spinae, latissimus dorsi, pectoralis major, anterior deltoid, biceps brachii, finger flexors, wrist flexor carpi ulnaris, and extensor digitorum). Manual muscle tests were performed prior to transport tasks in order to elicit maximum voluntary contractions (MVC) used in EMG signal normalization. Sixty-three infrared reflective surface markers were placed on anatomical landmarks of the head, arms, torso, and legs for use in kinematic motion capture data collection.

Prior to performing tasks, subjects were given an overview of the features specific to each seated transport device, and were allotted sufficient time to push each device about the lab space to become familiar with its function. Chair order between subjects was randomized.

Fourteen transport-tasks were completed for each device in an obstacle course simulating a clinical setting (Figure 2). The tasks included straightaway sections, 45°, 90°, and 180° turns, and a 5° inclined and declined ramp.

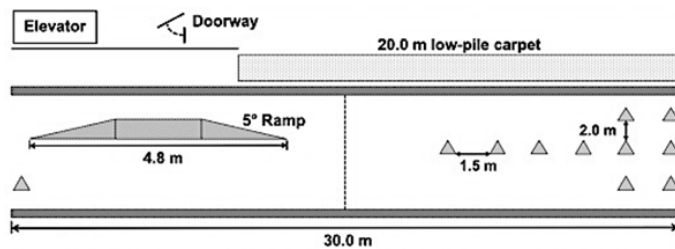

Figure 2: Patient Transport Obstacle Course

Muscle activation was recorded for selected tasks using bipolar surface electrodes (Noraxon Telemetry 2400T) sampling at 1500 Hz. Kinematic data were collected by a 20-camera Vicon motion capture software setup (Nexus 1.8.5) sampling at 100 Hz.

Data Analysis:

The data collected during a 30m level-surface straightaway pushing task with walking speed synchronized at 60 steps per minute was analyzed. A biomechanical analysis of joint angles was performed via custom Matlab (Version 7.4) code using kinematic data. Joint kinematics were defined and calculated using a modified Joint Coordinate System (JCS) vis-à-vis the standard recommended by the International Society of Biomechanics (Wu, 2002). Joint angles analyzed included trunk flexion, shoulder elevation and internal rotation, elbow flexion, wrist flexion, and ulnar deviation. Select joint angles are depicted in Figure 3. Muscle activation was integrated over the trial and normalized to the MVC recorded for that individual muscle.

A one-way repeated measures ANOVA test with three levels followed by paired comparison tests were used to compare caregiver integrated EMG and average joint angles across five gait cycles for each device. The level of significance was set to a p-value of $\alpha = 0.05$ or less. Statistical analysis was performed using SPSS Version 21 (SPSS Inc., Chicago).

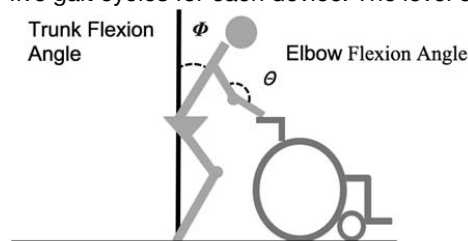

Results

The 22 subjects who participated in the study consisted of 9 males and 13 females. The group mean (\pm standard deviation) of age, height, weight, and years of clinical transport experience were 40 ± 18 years, 67.3 ± 4.2 inches, 171.6 ± 36.6 pounds and 7.6 ± 8.1 years, respectively. The study population consisted of healthcare professionals with at least two years of patient transport experience.

Integrated EMG values averaged across five gait cycles for each muscle (mean \pm standard deviation) can be seen in Table 1. Larger numbers indicate greater amounts of muscle activity. Definitions for muscle abbreviations are shown in Figure 4. Subjects demonstrated significantly greater muscle activation while operating the standard STC as compared to the ergonomic PTC and SXM in the left anterior deltoids ($p < 0.001$, $p = 0.001$), as well as when operating the STX compared to the PTC ($p = .045$). Extensor digitorum recruitment was greater when operating the SXM compared to the STC and PTC ($p = 0.044$, $p = .045$). Lastly, wrist flexor carpi ulnaris in both the left ($p = 0.002$) and right ($p = .045$) forearms were greater in STC compared to the PTC.

Figure 4. Muscle abbreviations key

Abbreviation	Muscle
<i>E.S.</i>	Erector Spinae
<i>Lat</i>	Latissimus Dorsi
<i>Pec</i>	Pectoralis Major
<i>ADelt</i>	Anterior Deltoid
<i>Bic</i>	Biceps Brachii
<i>FlexDig</i>	Finger Flexors
<i>WrFlex</i>	Wrist Flexor Carpi Ulnaris
<i>ExtDig</i>	Extensor Digitorum

Table 1. Peak integrated EMG (%MVC*sec) for PTC, SXM, and STC during level-surface straightaway pushing task. P-values for muscles with significant main effects are shown.

Muscle	PTC		SXM		STC		P-value
	Avg	S.D.	Avg	S.D.	Avg	S.D.	
<i>E.S. R</i>	410.1	246.4	363.4	128.3	307.7	68.2	
<i>E.S. L</i>	371.8	199.0	278.9	127.4	345.2	206.3	
<i>Lat R</i>	150.8 ¹	113.8	151.0	76.1	148.4	92.8	
<i>Lat L</i>	121.1	94.7	104.5	65.6	122.0	117.0	
<i>Pec R</i>	212.6	147.5	198.4	129.0	231.2	147.2	
<i>Pec L</i>	153.4	102.5	169.4	101.0	187.5	122.9	
<i>ADelt R</i>	69.7	65.3	64.5	81.6	72.8	95.1	
<i>ADelt L</i>	85.4	71.3	118.0	63.5	170.4	72.3	<.001 ¹ .001 ² .048 ³
<i>Bic L</i>	109.4	176.7	68.3	68.4	79.4	48.1	
<i>FlexDig R</i>	155.2	154.7	114.2	86.2	93.2	54.0	
<i>FlexDig L</i>	86.7	60.0	64.5	62.0	72.4	67.1	
<i>WrFlex R</i>	195.9	94.5	262.6	123.9	225.2	111.3	.045 ¹
<i>WrFlex L</i>	206.4	130.7	212.4	112.0	309.2	135.3	.002 ¹
<i>ExtDig R</i>	145.4	138.3	269.5	196.6	132.6	116.9	.045 ² .044 ³
<i>ExtDig L</i>	107.4	87.9	191.6	145.5	86.5	44.4	.025 ²

Significant paired differences at $\alpha = 0.05$: ¹ PTC to STC, ² SXM to STC, and ³ PTC to SXM

The average calculated joint angles (\pm standard deviation) can be seen in Table 2. Definitions for joint angle abbreviations are shown in Figure 5. Subjects exhibited significantly more elbow flexion ($p < 0.001$ to 0.01), less trunk flexion ($p < 0.001$), and less wrist deviation ($p < 0.001$ to 0.004) when operating PTC and SXM compared to STC. Shoulder internal rotation was larger for PTC than for SXM and STC ($p < 0.001$ to 0.004), and wrist extension was greater in SXM than for PTC and STC ($p = 0.005$ to 0.01). A negative value for wrist flexion indicates wrist extension; a negative value for ulnar deviation indicates radial deviation.

Figure 5. Joint angle abbreviations key

Abbreviation	Joint Angle
TrFlex	Trunk Flexion
ShouElv	Shoulder Elevation
Shoulnt Rot	Shoulder Internal Rotation
ElbFlex	Elbow Flexion
WrFlex	Wrist Flexion
UlnDev	Ulnar Deviation

Table 2. Mean joint angles calculated for PTC, SXM, and STC during level-surface straightaway pushing task. P-values for joint angles with significant main effects are shown.

Joint Angle	PTC		SXM		STC		P-value
	Avg	S.D.	Avg	S.D.	Avg	S.D.	
TrFlex	8.7	8.3	11.8	9.6	23.4	14.7	<.001 ¹ <.001 ²
ShouElv R	28.8	7.9	28.2	10.1	27.2	13.1	
ShouElv L	27.7	8.1	27.2	10.3	25.9	14.1	
Shoulnt Rot R	31.9	18.5	3.8	24.8	11.8	26.3	.004 ¹ <.001 ³
Shoulnt Rot L	37.4	22.9	11.9	27.1	25.1	27.8	.001 ³
ElbFlex R	58.0	13.7	67.4	14.4	35.8	9.6	<.001 ¹ <.001 ² .010 ³
ElbFlex L	58.4	12.0	66.4	15.3	36.7	9.4	<.001 ¹ <.001 ²
WrFlex R	-39.6	20.1	-54.9	12.1	-42.9	9.4	.010 ² .005 ³
WrFlex L	-40.5	18.7	-48.5	21.0	-38.3	14.6	
UlnDev R	-3.2	10.6	-8.6	12.5	4.5	9.7	<.001 ¹ .004 ²
UlnDev L	-5.2	10.4	-9.1	16.1	6.5	12.4	<.001 ¹ <.001 ²

Significant paired differences at $\alpha = 0.05$: ¹ PTC to STC, ²SXM to STC, and ³PTC to SXM

Discussion

Caregiver Muscle Activation:

The results of this study indicate that ergonomic seated transport device design has potential to reduce upper-body muscular demands of operators. Both the Stryker® Prime TC and Staxi® Medical Chair required less caregiver muscle activation in the anterior deltoids compared to the Breezy® Ultra 4 Wheelchair. The recorded differences are most likely the result of 1) biomechanically more favorable trunk and

elbow flexion angles (discussed below) and 2) more rigid and maneuverable frames of the PTC and SXM.

Operating the SXM required significantly greater extensor digitorum activation than both the PTC and STC. This difference is most likely due to the fail-safe handlebar brake mechanism of the SXM, which requires operators to continually grip a handle clamp to disengage the brake. Finally, subjects used significantly less wrist flexor carpi ulnaris activity when using the Stryker® Prime TC compared to the Breezy® Ultra 4 Wheelchair. This may be attributed to the ergonomically designed PTC supporting wrist angles that were closer to anatomical neutral as compared to the STC, and thus required less dynamic stabilization from the wrist musculature during the straightaway transport task.

Caregiver Joint Angles:

This study demonstrated that the ergonomically designed Stryker® Prime TC and Staxi® Medical Chair facilitated biomechanically more favorable trunk and elbow joint angles compared to the standard Breezy® Ultra 4 Wheelchair. Findings from this study suggest that PTC and SXM might alleviate work-induced lumbar pain by supporting a more biomechanically advantageous, upright pushing posture; STC may be an underlying contributor to back pain as caregivers must exert significantly greater trunk flexion in order to grip the push handles, resulting in a greater loading forces on their lumbar region.

The ergonomically designed PTC and SXM permit elbow flexion angles that are significantly nearer to the biomechanically-favorable 90° push angle (58° and 67°, respectively) than the STC (36°). This difference in elbow flexion may have been responsible for the significantly lower anterior deltoid muscle activity of subjects operating the PTC and SXM compared to the STC.

The observed differences in both trunk and elbow flexion angles can likely be attributed to the taller handle bar height in SXM (40.5") and the range provided by the upright handles in PTC (35-45") in contrast to the low, nonadjustable push handles in STC (32"). Differences in device push bar/handles location and orientation (e.g. vertical vs. horizontal) likely explains the differences recorded in caregiver shoulder internal rotation, wrist extension and deviation. The PTC supported closer to neutral wrist positioning and lower wrist muscle activation in comparison to the other two devices; this may reduce musculoskeletal strain on forearm muscles and protect the wrists from developing cumulative trauma injuries. The PTC handlebar design, while supporting better wrist posture, was also coupled with greater internal rotation at the shoulder than the other two devices. Extremes of shoulder elevation (e.g. abduction) and internal rotation are well known risk factors for shoulder muscle fatigue and impingement (Neer, 1983). However the mean shoulder positions observed across all the devices remained well within 'safe' operating limits (Pope, 2001; Hughes, 1984).

Conclusion

This study found that caregivers operating the ergonomically designed Stryker Prime TC and Staxi Medical Chair had better trunk and elbow postures than when using a standard wheelchair to transport a surrogate patient. Both ergonomically designed devices also required less shoulder deltoid activity and the Stryker chair required less wrist activity compared to the standard wheelchair and Staxi chair.

These results demonstrate the importance and efficacy of ergonomic design features in promoting better caregiver postures and reducing operator musculoskeletal strain. Implementation of ergonomic seated transport devices in hospitals and clinics has great potential to mitigate incidence of work-related musculoskeletal injury. Future studies analyzing functional usability, the effects of using seated ergonomically designed chairs on patient comfort and safety, and the ability of such devices to mitigate caregiver pain and injury are warranted.

Acknowledgements

Funding was provided by the National Science Foundation Research Experience for Undergraduate ASPIRE Grant #1262670, Stryker® Corporation through the VA Research Foundation, and by the National Institutes of Health through Grant Number UL1TR001857. The contents of this paper do not represent the views of the Department of Veterans Affairs or the United States Government.

References

1. Daikoku R, Saito Y. Differences between novice and experienced caregivers in muscle activity and perceived exertion while repositioning bedridden patients. *J Physiol Anthropol* 27(6): 333-9. Nov 2008.
2. Hughes RE, Silverstein BA. Risk factors for work-related musculoskeletal disorders in an aluminum smelter. *Am J Ind Med.* 1997;32:66-75.
3. Kothiyal K, Yuen TW. Muscle strain and perceived exertion in a patient handling with and without a transferring aid. *Occupational Ergonomics* (4): 185-197. 2004.
4. Lee SY, Kim SC. Comparison of Shoulder and Back Muscle Activation in Caregivers According to Various Handle Heights. *J Phys Ther Sci:* 1231-1233. Oct 2013.
5. Neer CS, II. Impingement lesions. *Clinical Orthopaedics & Related Research.* 1983;173:70-77.
6. Oranye O, Wallis B, Roer K. Do Personal Factors or Types of Physical Tasks Predict Workplace Injury? *Workplace Health Saf* 64: 141-151. April 2016.
7. Pope DP, Silman AJ, Cherry NM. Association of occupational physical demands and psychosocial working environment with disabling shoulder pain. *Ann Rheum Dis.* 2001;60:852-858.
8. Van der Woude LH, Van Koningsbruggen CM. Effect of push handle height on net moments and forces on the musculoskeletal system during standardized wheelchair pushing tasks. *Prosthet Orthot Int* 19(3): 188-201. Dec 1995.
9. Wu G, Siegler S, Allard P, Kirtley C. ISB recommendation on definitions of joint coordinate system of various joints for the reporting of human joint motion. *International Society of Biomechanics. J Biomech* 35(4): 543-8. Apr 2002.
10. Wunderlich GS, Sloan F. *Nursing Staff in Hospitals and Nursing Homes: Is It Adequate?* National Academies Press (US). 1996.

IC33: Introduction of a Total Shear Force Measurement Device, the iShear.

Max Paul Rogmans, MD

Introduction:

Pressure injuries are a common injury in healthcare leading to discomfort, pain, illness and sometimes death of the patient. Pressure injuries are predominantly considered to be preventable.

In recent years the definition of pressure injury has been adapted to include shear as a basic factor in the causation of pressure sores [1][2].

There seems to be a lot of confusion around the definition of the terms shear and friction[3]: they are used in conjunction with more extended terms like: Shear force, Shear stress, Tensile stress, Pinch shear, Hammocking, Static and/or Dynamic friction, Pressure, perpendicular force, normal force.

In the context of a person sitting in a wheelchair we are dealing with the following internal and external forces:

- Normal Pressure: a force in a 90 degree angle on the body. Pressure is force per unit area. Depending on immersion, envelopment, body weight, pressure distribution
- Column shear force: force applied as a result of the body mass mainly carried by the vertebral column resulting in tissue compression mainly around the ischial tuberosity and pinch shear alongside the pelvic tuberosity's.
- Pinch shear: when forces of a different magnitude are applied to neighbouring tissue, there is a tendency to move one plane more than another. This is pinch shear stress
- Tensile stress, a normal stress which pulls apart the material on either side of a plane.
- Sliding force: the force pushing the body out of the wheelchair as a result from leaning against the back support.
- Static Friction: the forces that exists prior to movement between 2 surfaces.

The resulting effect of all the above forces can be summarized in one term: tissue deformation.

Although there is a lot we still do not understand about the aetiology of pressure ulcers we do know that tissue distortion is an important factor leading to reduction of capillary blood flow, tissue damage, cell death and ulceration.

Shear Measurement:

Until now, pressure mapping has been the only clinical tool that has been widely used to evaluate the performance of the wheelchair seat systems. There have been numerous attempts to develop a device able to measure shear. These devices have always been focusing on the interface shear force. These are the shear forces between body and seat

system. Any device placed between body and seat plane will also alter the friction and shear forces between those two surfaces.

If we take all possible occurring shear forces into account there is only one shear force that we can easily influence by the correct set-up of the wheelchair and the right choice of seat and backrest[4]. This is the sliding force. The tendency of a wheelchair user to slide, is one of the most common problems that we try to overcome in our daily practice of setting up wheelchairs[5].

The iShear is a newly developed device that is intended to measure the total shear in the seat resulting from the force that occurs as a result from leaning against the back. The device is placed in the interface between cushion and seat base. It has an ultra-low friction core and two sensors that measure the force in the seat plane of the chair in a back to front and vice versa direction. The force measured by the device is defined as the Total-Shear-Force (TSF). The iShear can also be used to identify rotational forces occurring in the seat plane as a result of anatomical and/or functional left to right differences.

The iShear is a new clinical tool. Possible advantages and applications for clinical use could be:

- Assessing the risk for a wheelchair user to slide
- Asses the time needed for a wheelchair user to slide, the effect of sliding on the TSF
- Real time impact measurement of the wheelchair set-up on TSF: determine the influence of for instance back support angle, pelvic position, seat angle, leg position on TSF.
- TSF over time: effect of propulsion
- Documentation of wheelchair set-up
- Education of colleges and users

The iShear measurements can be displayed, stored and mailed on a smartphone or tablet through a Bluetooth connection. Measurements can be taken up until 8 hours with as little as 1.8 second intervals. Data can be exported for graphical display in Excel.

A well working prototype of the device has been made available for evaluation purposes to a selected number of clinicians throughout Europe and North America. Preliminary results of this evaluation will be discussed.

Objectives

1. Discuss various forms of shear forces and understand what the differences are.
2. Relate three factors that affect shear forces relating to a wheelchair set-up.
3. Demonstrate knowledge to set-up a wheelchair.
4. Demonstrate knowledge to set-up a wheelchair with use of the iShear.

References:

1. Stockton, L., Gebhardt, K. S., & Clark, M. (2009). Seating and pressure ulcers: Clinical practice guideline. *Journal of Tissue Viability*, 18(4), 98-108. doi:10.1016/j.jtv.2009.09.001
2. Lahmann, N. A., & Kottner, J. (2011). Relation between pressure, friction and pressure ulcer categories: A secondary data analysis of hospital patients using CHAID methods. *International Journal of Nursing Studies*, 48(12), 1487-1494. doi:10.1016/j.ijnurstu.2011.07.004
3. Hanson, D., Langemo, D. K., Anderson, J., Thompson, P., & Hunter, S. (2010). Friction and Shear Considerations in Pressure Ulcer Development. *Advances in Skin & Wound Care*, 23(1), 21-24. doi:10.1097/01.asw.0000363489.38996.13
4. Gilsdorf, P., Patterson, R., Fisher, S., & Appel, N. (1990). Sitting forces and wheelchair mechanics. *The Journal of Rehabilitation Research and Development JRRD*, 27(3), 239. doi:10.1682/jrrd.1990.07.0239
5. Kamegaya T, (2016). Influence of sacral sitting in a wheelchair on the distribution of contact pressure on the buttocks and back and shear force on the ischial region. *J Phys Ther Sci*. 2016 Oct;28(10):2830-2833. Epub 2016 Oct 28.

IC34: Mobility Addendums: Getting it Right the FIRST Time!

Dan Fedor

You choose the profession of OT / PT to help people. Your goal is to rehabilitate patients, however, when that is no longer an option, you are required to determine the medically necessary mobility equipment that will enable your patients to remain independent in performing their activities of daily living. This is a rewarding profession. What's not rewarding is the amount of time you have to spend preparing documentation for third party payers. However, this documentation is required in order for your patient to receive the medical necessary equipment and for them to have the least amount of financial liability for those items. It is essential that you are efficient in preparing this documentation in order to be able to spend more time on why you chose this profession in the first place and that is to treat patients.

One of the most frustrating things for a clinician is when you know your patient requires a piece of mobility equipment but you are told they don't qualify per Medicare's policy.

In this interactive workshop participants will gain insight into Medicare's (and many other payers - Medicaid, etc.) documentation requirements for mobility assistive equipment (MAE) and related accessories including seating and positioning. The instructor will present in a clear understandable manner what Medicare expects from a clinician to determine if medical necessity has been established. Participants will have a hands on experience by reviewing actual face to face notes and wheelchair evaluations (of course patient information removed for HIPAA compliance) and with the instructors guidance determine if the documentation provided supports the need for the items ordered.

This course will enable attendees to effectively document the medical necessity for mobility assistive equipment and related accessories, the first time, for qualified patient. This will eliminate the need for addendums and the unnecessary delays in the patient receiving the necessary mobility equipment.

If you are you tired of having to write addendums for your wheelchair evaluations please invest time in this class and become more efficient when preparing wheelchair evaluations. Learn to Speak Medicare Language and be able to effectively document the medical necessity for mobility assistive equipment (MAE) and related accessories.

References

1. Centers for Medicare and Medicaid Services. (2015). Local Coverage Determination (LCD): Power Mobility Devices. Retrieved from [https://www.cms.gov/medicare-coverage-database/details/lcd-details.aspx?LCDId=33789&ContrlId=140&ver=9&ContrVer=2&CntrctrSelected=140*2&Cntrctr=140&name=CGS+Administrators%2c+LLC+\(18003%2c+DME+MAC\)&DocType=Active&LCntrctr=140*2&bc=AgACAAQAAAAAAAA%3d%3d&](https://www.cms.gov/medicare-coverage-database/details/lcd-details.aspx?LCDId=33789&ContrlId=140&ver=9&ContrVer=2&CntrctrSelected=140*2&Cntrctr=140&name=CGS+Administrators%2c+LLC+(18003%2c+DME+MAC)&DocType=Active&LCntrctr=140*2&bc=AgACAAQAAAAAAAA%3d%3d&)
2. Centers for Medicare and Medicaid Services. (2016). Local Coverage Determination (LCD): Wheelchair Seating (L33312). Retrieved from [https://www.cms.gov/medicare-coverage-database/details/lcd-details.aspx?LCDId=33312&ContrlId=140&ver=10&ContrVer=2&CntrctrSelected=140*2&Cntrctr=140&name=CGS+Administrators%2c+LLC+\(18003%2c+DME+MAC\)&DocType=Active&LCntrctr=140*2&bc=AgACAAQAAAAAAAA%3d%3d&](https://www.cms.gov/medicare-coverage-database/details/lcd-details.aspx?LCDId=33312&ContrlId=140&ver=10&ContrVer=2&CntrctrSelected=140*2&Cntrctr=140&name=CGS+Administrators%2c+LLC+(18003%2c+DME+MAC)&DocType=Active&LCntrctr=140*2&bc=AgACAAQAAAAAAAA%3d%3d&)
3. Centers for Medicare and Medicaid Services. (2013). Local Coverage Determination (LCD): Wheelchair Options/Accessories (L11473). Retrieved from [https://www.cms.gov/medicare-coverage-database/details/lcd-details.aspx?LCDId=33792&ContrlId=140&ver=9&ContrVer=2&CntrctrSelected=140*2&Cntrctr=140&name=CGS+Administrators%2c+LLC+\(18003%2c+DME+MAC\)&DocType=Active&LCntrctr=140*2&bc=AgACAAQAAAAAAAA%3d%3d&](https://www.cms.gov/medicare-coverage-database/details/lcd-details.aspx?LCDId=33792&ContrlId=140&ver=9&ContrVer=2&CntrctrSelected=140*2&Cntrctr=140&name=CGS+Administrators%2c+LLC+(18003%2c+DME+MAC)&DocType=Active&LCntrctr=140*2&bc=AgACAAQAAAAAAAA%3d%3d&)
4. CGS Administrators, LLC. (2016). DME MAC Jurisdiction C. Retrieved from <http://www.cgsmedicare.com/jc/>
5. Noridian Healthcare Solutions. (2016). DMEPDAC. Retrieved from <https://www.dmepdac.com/>

IC35: Are Environmental Control Units (ECUs) a thing of the Past?

Tricia Garven, MPT, ATP
Elisa Hopwood, OTL
Mary Linh Simonson, OTL

Authors and Presenters:

Tricia Garven, MPT, ATP
Permobil, Inc.
Tricia.Garven@permobil.com

Elisa Hopwood, OTL
Santa Clara Valley Medical Center
Elisa.Hopwood@hhs.sccgov.org

Mary Linh Simonson, OTL
Santa Clara Valley Medical Center
Mary.Simonson@hhs.sccgov.org

Advances in wireless technologies have changed how consumers with mobility impairments are able to control their environment. Mobile phones, tablets and computers are now normal in everyday life. This course will explore how consumers can perform electronic ADLs through integrating commercially available smart technologies via direct access solutions or power wheelchair electronics. Specific attention will be paid to mobile devices with built in accessibility features, and the complimentary products, to increase or create usability for wheelchair users.

References:

1. Cook, A. M., Polgar, J. M., & Hussey, S. M. (2008). Cook & Hussey's assistive technologies: Principles and practice. St. Louis: Mosby Elsevier.
2. Guerette, P., & Sumi, E. (1994). Integrating Control of Multiple Assistive Devices: A Retrospective Review. *Assistive Technology*, 6(1), 67-76. doi:10.1080/10400435.1994.10132228
3. Hreha, K., & Snowdon, L. (2011). We All Can Call: Enhancing Accessible Cell Phone Usage for Clients With Spinal Cord Injury. *Assistive Technology*, 23(2), 76-80. doi:10.1080/10400435.2011.567373
4. Handsfree by Christopher Hills & Luis Perez on iBooks. (n.d.). Retrieved June 17, 2016, from <https://itunes.apple.com/us/book/handsfree/id1040716154?mt=13>

Additional Website Resources:

1. <https://www.ablenetinc.com/>
2. <http://www.apple.com/accessibility/ios/>
3. <http://www.appleworld.today/blog/2015/3/23/accessible-apple-building-a-wheelchairbed-mounted-idevice-setup-part-1>
4. <https://craighospital.org/services/assistive-technology/assistive-tech-phone-access-resources>
5. <https://support.google.com/accessibility/android#topic=6007234>

IC36: Group Wheelchair Skills Training – Setting and Achieving Goals

Lynn Worobey, PhD, DPT, ATP

Rachel Hibbs

Jessica Presperin Pedersen, OTR/L,
ATP

Mary Shea, MA, OTR, ATP

Many wheelchair users lack skills crucial for independence, safety and upper limb preservation. Unfortunately, individualized training is increasingly difficult with the shortened lengths of stay. This session will discuss the logistics of group wheelchair skills training as a potential solution including: goal setting, scheduling, space and supply needs, group dynamics, and accommodating users with different baseline skill levels. The effectiveness of a multi-site randomized control trial utilizing this intervention will be presented with case examples.

Learning Objectives:

Upon completion of this session, attendees will be able to;

- List two barriers and two facilitators to group wheelchair skills training.
- Describe two wheelchair skills development strategies to maximize an individual's independence and safety with negotiating their wheelchair.
- Compare/contrast the implementation of group wheelchair classes in different healthcare systems to determine two potential mechanisms for incorporating group training into one's own clinical practice.

References:

1. Worobey, L. A., Kirby, R. L., Heinemann, A. W., Krobot, E. A., Dyson-Hudson, T. A., Cowan, R., ... & Boninger, M. L. (2016). Effectiveness of Group Wheelchair Skills Training for People with
2. Spinal Cord Injury: A Randomized Control Trial. Archives of physical medicine and rehabilitation. Best, K. L., Kirby, R. L., Smith, C., & MacLeod, D. A. (2005). Wheelchair skills training for community-based manual wheelchair users: a randomized controlled trial. Archives of physical medicine and rehabilitation, 86(12), 2316-2323.
3. Hosseini, S. M., Oyster, M. L., Kirby, R. L., Harrington, A. L., & Boninger, M. L. (2012). Manual wheelchair skills capacity predicts quality of life and community integration in persons with spinal cord injury. Archives of physical medicine and rehabilitation, 93(12), 2237-2243.

IC37: School of Power Mobility: Tips for Teaching Power Mobility Skills

Angie Kiger, M.Ed., CTRS, ATP/SMS
Robin Skolsky, PT, ATP

Abstract:

Are you searching for exciting yet effective strategies for teaching power mobility skills? If so, then you need to be at this presentation! During this session you will learn tips and tricks for creating a successful power mobility training program including considerations for setting-up the environment, communication techniques, ideas for developing skills while the client is not in a power wheelchair, and activities for power mobility training sessions while the client is “behind the wheel.”

Learning Objectives:

- Identify at least three (3) strategies that go into creating an environment for successful power mobility training.
- List three (3) activities an end user can engage in to practice power mobility driving skill development while not in a power wheelchair.
- Describe five (5) activities that can be incorporated into the curriculum of power mobility training session.
- Outline the steps required to complete a thorough power mobility evaluation.

Introduction:

Ralph Waldo Emerson has been credited with saying “The man (or woman) who can make hard things easy, is the educator.” In the world of complex rehab technology, clinicians and suppliers often find themselves serving as not only the evaluators and recommenders of equipment, but also trainers/educators especially when it comes to power mobility.

Independent mobility can have a tremendous impact on the development and/or rehabilitation of areas such as learning, communication, mobility, socialization, recreation, vision, and self-care (Anderson et al., 2013). In addition, it can also help maintain a quality of life and enhanced feelings of self-worth in the aging population that otherwise becomes dependent upon others (Pettersson, Tornquist, Ahlstrom, 2006; Brandt, Iwarsson, Stahl, 2004). Research supports theories surrounding the utilization of power mobility with users ranging from babies as young as 7 months (Lynch, Ryu, Agrawal, & Galloway, 2009) to older adults.

Innovative technology for power wheelchairs is coming onto the market at lightning fast speeds. Alternative input devices make it possible for clients to drive with virtually any body part that the individual has the ability

to volitionally move. Children who have never had mobility can develop a consistent means of independent mobility and those who have aged and become less mobile can learn a new means of mobility to help them maintain a sense of independence.

In order for a client to become a successful power wheelchair user all he needs is the proper equipment and set-up, right? Not so fast. When you were learning to drive, did you simply slide behind the wheel of a car and take-off without any evaluation or training? Hopefully the answer is “no.” Instead you most likely participated in some of form driver’s education program that required skill development while driving and outside of the car.

Older clients have likely had experience riding in and driving motor vehicles in the past. Some adults report that learning to drive a power mobility device is reminiscent as to learning to drive a car; however the rules of the road were different (Mortenson et al., 2005). Children differ when it comes to techniques for learning to operate a power mobility system, because many of the children have never driven a vehicle much less moved themselves independently. While the end goal of providing independent mobility through power mobility may be the same for all clients, the methods used to evaluate, train, and test each client may be impacted by factors such as age, experience, cognitive level, etc.

The primary objective of this discussion is to provide strategies needed to develop a power mobility training program with curriculum that is exciting and effective for clients. To begin the session considerations for setting-up the environment, communication techniques, and expectations of the entire team will be reviewed. Activity ideas for developing skills while the client is not in a power wheelchair will be presented, followed by curriculum ideas for power mobility training sessions while the client, young and old, is “behind the wheel”.

Process:

Prior to recommending any type of assistive technology for a client of any age, it is essential that a thorough evaluation be completed. In general, an Assistive Technology (AT) evaluation should include the following: a review of the client’s medical history, an interview with client and caregiver, assessment of the client’s current abilities, a seating and positioning assessment, equipment trial, recommendation of equipment, completion of documentation and the funding process, equipment delivery, training of the prescribed equipment, and follow-up (Cook & Polgar 2008). However, when it comes to evaluating and recommending a power mobility system equipment, additional considerations come into play especially if the individuals is being evaluated for his/her first piece of seating and mobility equipment.

Whether your client is 7 months or 97 years, having family and/or caregiver support is paramount. The complete support of the overall treatment is also vital. In the majority of cases developing the skills required to independently utilize a power wheelchair can be accomplished in settings beyond the time spent practicing driving the wheelchair including speech therapy, recreation therapy, during activities of daily living, at

school, etc. Effort on behalf of the entire support team takes time and energy, but the payoff can be exceptional. Once the proper seating has been identified and the client's team has bought into the end goal, evaluating client's baseline skills is a good idea to determine how much training may be required. Many institutions and schools have developed check lists, protocols, and/or standards to help treatment teams decide when a client exhibits the necessary skills for power mobility. In addition there are a few standardized evaluation tools available to aide in determining power mobility readiness including the Assessment of Learning Power mobility use (ALP). Unfortunately, in a recent survey of assistive technology practitioners only about 1/3 of the respondents, all of whom identified themselves as prescribers of power mobility, reported that they were aware of standardized performance based power mobility evaluations (Jenkins, Vogtle, & Yuen, H., 2015). The increased awareness and utilization of such tools may increase the success of power mobility evaluations and training.

Developing a lesson plan or curriculum for each client to teach specific skills is helpful. In the world of education a lesson plan is considered detailed guide that includes goals, objectives, direct instruction, and guided practice. Many of those same principles can be utilized when helping a client learn to be independent through the use of power mobility. Tailoring each plan to the individual client is essential, because no two learners are the same. Identifying proper goals, motivating activities, and timelines will be driven by the client's specific learning style and needs.

Conclusion:

Overall, once the desire to pursue an independent means of mobility is discovered, it should be explored. Funding issues and logistics aside, when a client who has the desire, required foundational abilities, and ability to develop more skills is teamed up with knowledgeable clinicians and a complex rehab technology supplier, the ability learn to drive is greatly increased. Now it's time to learn about the tools and resources to improve your abilities to empower your clients through power mobility.

References:

1. Anderson, D., Campos, J., Witherington, D., Dahl, A., Rivera, M., He, M., ... BarbuRoth, M. (2013). The role of locomotion in psychological development. *Frontiers in Psychology*, 4(July), 440.
2. Brandt A, Iwarsson S, Stahl A. Older people's use of powered wheelchairs for activity and participation. *J Rehabil Med* 2004; 36:70-77.
3. Cook, A., Polgar, J. *Cook and Hussey's Assistive Technologies: Principles and Practice 3e*. Philadelphia: Mosby (2008)
4. Edwards, K., & McCluskey, A. (2010). A survey of adult power wheelchair and scooter users. *Disability and Rehabilitation: Assistive Technology*, 5(6), 411-419.
5. Livingstone, R. & Paleg, G. (2014) Practice Considerations for the Introduction and Use of Power Mobility for Children. *Developmental Medicine and Child Neurology*. Volume 56, Issue 3, Pages 210-221
6. Jenkins, G. R., Vogtle, L. K., & Yuen, H. K. (2015). Factors Associated With the Use of Standardized Power Mobility Skills Assessments Among Assistive Technology Practitioners. *Assistive Technology*, 27(4), 219-225.
7. Jones, M., McEwen, I., & Neas, B. (2012) Effects of Power Wheelchairs on the Development and Function of Young Children with Severe Motor Impairments. *Pediatric Physical Therapy*, 131-140
8. Lynch A, Ryu JC, Agrawal S, Galloway JC. Power mobility training for a 7-month-old infant with spina bifida. *Pediatr Phys Ther*. 2009; 21: 362-8.
9. Mortenson, W.B., Miller, W. C., Boily, J., Steele, B., Odell, L., Crawford, E. M., & Desharnais, G. (2005). Perceptions of Power Mobility Use and Safety within Residential Facilities. *Canadian Journal of Occupational Therapy*, 72(3), 142-152.
10. Nilsson, L., & Durkin, J. (2014). Assessment of learning powered mobility use-Applying grounded theory to occupational performance. *Journal of Rehabilitation Research and Development*, 51(6), 963-74.
11. Pettersson I, Tornquist K, Ahlstrom G. The effect of an outdoor powered wheelchair on activity and participation in users with stroke. *Disabil Rehabil: Assist Technol* 2006; 1:1-9.

I, Angie Kiger, have/had an affiliation with an equipment, medical device or communications organization during the past two calendar years. I am employed full time by Sunrise Medical US, LLC as clinical educator. I do not intend to promote or endorse any particular brand or product as a part of this clinical presentation.

I, Robin Skolsky, have not had an affiliation with an equipment, medical device or communications organization during the past two calendar years. I am employed by the Shepherd Center as a physical therapist in the Seating and Mobility Clinic. I do not intend to promote or endorse any particular brand or product as a part of this clinical presentation.

IC38: Driving for Change: Ending Barriers and Paving the Way for Play

Andrina J. Sabet, PT, ATP

Heather A. Feldner, PT, PhD, PCS

The concept of early mobility is gaining traction in the clinical world and in communities around the country. Theory and clinical research demonstrate both the benefits of early power mobility as well as increasing acceptance of this practice. Mobility in the infant, toddler and preschool population has impact beyond getting from point A to point B. During this critical time of development, mobility is a driving force behind exploration and socialization. The ability to explore both the physical world and behavioral boundaries creates an interactive platform to fuel learning, cognition, and language.

But even if stakeholders are philosophically committed to providing powered mobility access, additional barriers remain in the practical implementation of equipment options that are currently available within the mobility industry. In the DME world, the physical nature of power wheelchairs can be exclusionary due to size and weight. In the therapeutic community, the resources of time, access to equipment and an understanding of how to implement alternative access can limit options of exploring power mobility with their clients. And families struggle with attempts to integrate technology that is often overwhelming.

This presentation provides an interactive exploration of these implementation barriers, including equipment design, power access, environmental accessibility, stakeholder perceptions, and multiple layers of gatekeeping. Input from families, children, researchers and clinicians will be utilized in demonstrating an urgent need for change.

Break-out brainstorming in small groups will discuss these challenges while creating a foundation for problem solving where solutions can emerge, and be implemented by session participants within their own practice environments. Critical assessment of current barriers combined with out of the box ideas to break down or challenge them is the overarching goal for the session. It is critical to better define and isolate these challenges so they can be confronted on both the individual and industry levels. Participants will come away with practical solutions for promoting a multi-modal mobility approach that is designed to call all explorers off the sidelines.

References:

1. Livingstone, R., & Field, D. (2015). The child and family experience of power mobility: a qualitative synthesis. *Developmental Medicine & Child Neurology*, 57(4), 317-327.
2. Ostensjø, S., Carlberg, E. B., & Vøllestad, N. K. (2005). The use and impact of assistive devices and other environmental modifications on everyday activities and care in young children with cerebral palsy. *Disability and Rehabilitation*, 27(14), 849-861.
3. Feldner, H. A., Logan, S. W., & Galloway, J. C. (2016). Why the time is right for a radical paradigm shift in early powered mobility: the role of powered mobility technology devices, policy and stakeholders. *Disability and Rehabilitation: Assistive Technology*, 11(2), 89-102.

IC39: Conquer the Complexity of Writing a Letter of Medical Necessity

Erin Baker, PT, ATP, CPST

Mobility evaluations for complex rehab are challenging, but beyond the evaluation the thought of completing the required paperwork to gain funding for this equipment is overwhelming. Writing a quality letter of medical necessity (LMN) is an important component to acquiring funding and ultimately to providing appropriate and necessary seating and mobility products to clients. Thankfully, composing a LMN does not have to be as time consuming and daunting as one may think. This instructional course is designed to address the common concerns and fears about writing a LMN, provide education regarding the components that should be included in a LMN, and discuss how to make the writing process efficient and effective.

A high quality LMN is imperative for multiple reasons and is directly related to being able to provide necessary equipment to an individual who requires seating and mobility equipment. In a LMN it is necessary to be able to clearly and concisely express to someone who may have no background in durable medical equipment the needs of an individual the reviewer knows nothing about.

Concerns regarding style and content of a LMN are common and have led to use of premade forms and LMN generators. While these resources are helpful, they often provide only the information needed to complete justification of the equipment and its components but do little to aid in describing the individual and their needs. In order to explain why a piece of seating or mobility equipment is medically necessary the reviewer needs to understand who the individual is as a person, what their medical condition is, how this condition affects them physically, as well as how it affects their ability to participate in their world day to day. In this course we will discuss the essential components of a top notch LMN as well as how to organize it in a clear and succinct manner.

In an environment where funding is decreasing and the paperwork necessary to try and get what little funding is available, time has become a fleeting commodity. LMN's are required paperwork for most payer sources, but most do not have the available time needed to create these documents. Fortunately with time and practice, as well as some help from ever evolving technology, I have found several ways to decrease the time needed to generate a LMN without compromising quality. These methods have significantly cut down on time spent sitting behind a computer, which in turn increases the speed with which the process of acquiring seating and mobility equipment begins and decreases the time an individual in need must wait for their equipment.

While seating and mobility equipment can be very complicated, the process of getting it does not have to be. With methods and tips from a full-time seating and mobility therapist you too can create a comprehensive LMN which will reduce the chance of denial and decrease wait time for the

individual in need. Not only will you be able to generate a high quality LMN, but also complete it in a reasonable time frame which will decrease stress and frustration with the seating and mobility equipment acquisitions process.

References

1. Neighborhood legal services. Preparing letters of medical justification: Key components that will support the need for Durable medical equipment through Medicaid and other third party insurers. AT advocate Winter 2006; 1:326-336
2. http://www.wheelchairnet.org/wcn_prodserv/funding/funding.html
3. <https://www.cms.gov/Outreach-and-Education/Medicare-Learning-Network-MLN/MLNProducts/downloads/powerWheelchair.pdf>
4. https://www.cms.gov/Outreach-and-Education/Medicare-Learning-Network-MLN/MLNProducts/downloads/PMDFactSheet07_Quark19.pdf
5. Private or Commercial Insurance company websites/policies

I, Erin Baker, do not have an affiliation (financial or otherwise) with an equipment, medical device, or communications organization.

IC40: New & Emerging Technologies: How to Ask the Right Questions When Evaluating Mobility Devices

Kendra Betz, MSPT, ATP

Objectives: Upon completion of the session, participants will be able to:

- Review three critical considerations for evaluating new and emerging wheeled mobility devices.
- Discuss two reasons that objective results from standardized test protocols provide meaningful information about mobility device performance.
- Describe three common wheeled mobility device failure modes that result in challenges for wheelchair users.

New technologies that support increased mobility and participation for individuals with physical impairment are consistently developed and introduced to the rehabilitation community. Product innovations capture a wide realm of proposed mobility solutions, ranging from unique ambulation assistive devices, to highly customizable wheeled mobility options and rapidly evolving powered exoskeletons that support individuals who are paralyzed to stand and walk. Within each mobility device category, extensive variability exists. As just one example, manual wheelchairs are available with a multitude of frame designs and features, are built with diverse materials, and are highly customizable by configuration, individualized selection of options and accessories, and interface with complementary mobility enhancing products such as power add-on systems. Often, limited objective evidence is available about the appropriate use and effectiveness of a new mobility device, yet rehabilitation professionals must respond to consumers who believe it is a “must have,” to product representatives who promote it as the “greatest invention ever” and to funding sources who insist it is an “unnecessary expense”. Many people are challenged to strategically analyze mobility products to differentiate between beneficial attributes and limits of use based on the information available.

Asking pertinent questions and assimilating available information supports an accurate and meaningful assessment of potential value and identified limitations of new, emerging and existing mobility technologies. Answers to the following questions provide critical information to support mobility device evaluation.

1. **What is this device?**
Includes general product overview and specific device features, intended consumer population, appropriate environments of use and known limitations.
2. **What’s known about the company that builds and distributes this device?**
Companies range from small businesses to large corporations, with varied experience in the industry. The location of the parent company, manufacturing facilities, and distribution centers may be pertinent along with availability of customer service support.
3. **How is this device regulated?**
Device regulation varies by country. In the US, the FDA regulates medical devices and outlines the requirements for companies and products.
4. **Has the device been tested?**
International and national standards exist for testing mobility devices to determine safety, performance, durability, reliability, dimensions, device weight and weight capacity and other important objective measures. Requirements for device labeling are also specified.
5. **What’s been published about this device?**
Review of published research highlights pertinent findings about a unique device, groups of products, or specific device features. Levels of evidence range from randomized clinical trials to case studies. Some companies maintain bibliographies of relevant publications.
6. **Are there safety concerns?**
Review of reported adverse events and recalls identifies potential concerns and/or guides further inquiry. Public sources range from government managed databases to informal device reviews and uncensored social media.
7. **What are the current funding sources?**
Information about current and past funding sources and coverage policy is relevant, including CMS, VA, private insurance and Workman’s Comp. Mobility devices are assigned HCPCS codes by the Medicare Pricing, Data Analysis and Coding (PDAC) contractor.
8. **How well does this device work?**
Whenever possible, use the product or simulate use to determine if the device is intuitive to operate and reasonably managed by the intended population. Assess usability in varied environments, including operation of all features, available adjustments and programmability, and installation of accessories. Determine advantages or limitations related to interface of the device with other assistive technologies. Understand care, maintenance, storage, and transportation requirements and resources available to the consumer. Determination of device efficacy may be supported by outcome measurement tools.

9. **What are the education and training requirements?**

Details about the education and training required for clinical providers, consumers and technical support personnel to use and manage the device safely and effectively must be identified. More complex or unique devices may include an organized training protocol with demonstrated competency required to either issue or use the device.

10. **Are there any ethical or special considerations for this device?**

Professional codes of conduct apply when assessing mobility devices and providing information or recommendations to consumers. Product details should be disclosed to the extent that information is available. In certain circumstances, additional risk management strategies are recommended to support optimal patient safety. Education should be provided to consumers about anticipated evolution of new technologies and associated future opportunities.

References/Recommended Reading

1. U.S. Food and Drug Administration Guidance on Medical Device Regulation <http://www.fda.gov/MedicalDevices/DeviceRegulationandGuidance/Overview/ucm134499.htm> Accessed January 2017.
2. Gebrosky B, Pearlman J, Cooper RA, Cooper R, Kelleher A. Evaluation of lightweight wheelchairs using ANSI/RESNA testing standards. *J Rehabil Res Dev.* 2013; 50(10):1373–90.
3. Iezzoni LI, Ogg M. Performance metrics for power wheelchairs: a pipe dream? *Arch Phys Med Rehabil.* 2014; 95(4): 604-7.
4. Lajeunesse CV, Routhier F, Careau E, Michaud F. Exoskeletons' design and usefulness evidence according to a systematic review of lower limb exoskeletons used for functional mobility by people with spinal cord injuries. *Disability and Rehabilitation: Assistive Technology.* 2016; 11(7):535-47.

Contact:

Kendra Betz

University of Pittsburgh/Veterans Health Administration
Denver, CO
United States
Kendra.Betz@comcast.net

PS5.1: Second Generation of a Low-Cost Smart Wheelchair

Carlos Goncalves, MEng

Valeria Baldassin, PT

William Gouvea Dias

Abstract:

During ISS 2015 we presented a prototype of a low cost smart wheelchair designed to help the rehabilitation professional to select the best functional movement and control strategy to use the device, as well as provide people with severe motor disabilities the opportunity to test a power wheelchair. This solution needed few electronic components, maintaining its low-cost. Wheelchairs with variability of input or control types are unreachable for the communities in development countries. With this prototype we have already attended 30 patients since 2013 in SARAH Network of Rehabilitation Hospitals with multiple diagnostics (cerebral palsy, traumatic brain injury, spinal cord injury, polio and artrogriposis) and functional movements (head, hand, feet, chin, mouth). The test made with this wheelchair is the first stage of a test-prescribe-adapt process. Our second prototype keeps the features of the previous and extends the use of the device in terms of ergonomics and safety position. Thus, a single power wheelchair can be used by children and adults, since its seat and backrest are both adjustable. With this new device, the tests for a power wheelchair will reach a wider range of patients.

Keywords: smart wheelchair, wheelchair prescription, input testing.

Introduction

By the mid 80's, smart wheelchairs projects have been developed as applications of mobile robotics techniques with the goal to permit those persons with more limitations in movement and/or coordination could benefit from a power-wheelchair. Those equipments had different sensors, control interfaces and control strategies, permitting a broader range of possible users. But those features were not applied to the mainstream market of power-wheelchairs (Simpson, 2005). Until today, different projects of smart wheelchairs are still in development in universities and research centers around the world. Robotic teams find in this particular field of interest an opportunity to use the mobile robotics frameworks to create a rehabilitation device.

Most of the teams nowadays rely on systems that use laser scanners to create a map of the environment (Carlson & Demiris, 2012; Leishman, Horn, & Bourhis, 2010; Montesano, Minguez, & Marta, 2009; Rofer, Mandel, & Laue, 2009), others rely on the combination of the image information and depth sensing (Montella, Pollock, Schwesinger, & Spletzer, 2012). These approaches can create fully automatic systems,

where the user input (gesture, voice, EEG, and others) can select directly, or through scanning, the destination, and the wheelchair will reach the desired position, as well "driving assistance" features where the control system takes control if the user needs help or is heading towards a collision.

Those features permit a broader range of possible users with involuntary movements, cognitive impairment, lack of fine movement control, or even limited or no existence hand control. But those systems are not meant for mass production (Simpson, 2008). Even knowing that those features are necessary, wheelchair factories do not implement them because of their complexity and cost.

Most of the times, simple features can be enough to increase the number of possible users. Just the possibility of changing the input control interface is very important during wheelchair testing. Some models in America and Europe have this option, but it is something totally unreachable in under development countries. To cite one case, in (Edmy et al., 2015) the main goal of the authors is to create a modular power wheelchair to make increase the access of these technologies for the community in Colombia.

Our previous work in ISS 2015 (Baldassin & Gonçalves, 2015) presented our idea of a smart wheelchair design to have simple features made from low-cost components that could permit testing multiple input interface and control strategies prior a prescription. This is the first step in a test-prescribe-adapt process which provides for the final users an adaptation for his regular power wheelchair that permits their control.

This paper describes how the system was improved in its second prototype and how it can be used for an even broader range of patients in SARAH Network of Rehabilitation Hospitals.

Material and Methods

In our previous work, we resorted in an old x-frame power wheelchair, 40cm width, with a regular joystick command that could be used with the right hand. That wheelchair was adapted with a control unit with a LCD display, six ultrasonic range finders, and an emergency switch.

The control unit bypass the original joystick with the same strategy used in others studies (Leishman et al., 2010; LoPresti, Sharma, Simpson, & Mostowy, 2011), creating an output analog signal with the same pattern as the original joystick. This unit could receive the inputs from a second joystick that was not attached to the wheelchair, USB mouses, and single switch sensors. The sensors and the emergency switch were used to provide greater safety for the system. Wall-following strategy was also possible to use during trials.

Despite the seating position limited by the rigid frame and fixed backrest, we were able to use the equipment with 30 patients from 2013 until 2016. The main features for the new prototype were focused in better seating adjustment options and some enhancements in control strategies.

Figure 1: Old smart wheelchair (left) and new prototype (right).



Previous features

All the features from the previous prototype (Baldassin & Gonçalves, 2015) were maintained notably: emergency switch, control unit with LCD display, ultrasonic rangefinders, and the multiple control features (wall following, joystick input, single switch input, USB mouses).

In the sections below we focus on the differences between each prototype.

Seating features

In our previous prototype, 12 of the 30 patients that tested the system had less than 16 years of age. With that in mind, the second prototype should be able to adjust its seat width, the armrests heights, the footrest height, the width and the angle of the backrest.

Designs like this are not common since wheelchair manufacturers deliver models that are fit for a very specific body profile of the user. Child wheelchairs will in most cases be replaced by adults wheelchairs in some time of the life of the patients.

Although, since we plan to have only one model to test with the broadest range of patients, our design had to cope with the mentioned restrictions. This was accomplished by using pre-fabricated metal profiles where the structure of the seat and backrest could slide. With this, the wheelchair could be adjusted from 36cm to 46cm of seat/backrest width. The adjustment of height in the footrest is done manually but the angle of the backrest is controlled electronically with a linear motor.

Figure 2: Possibilities of seating adjustments (from left to right): seat and backrest with 36cm of width, seat and backrest with 46cm of width, and backrest angle adjustment.



Enhanced input positioning

The new prototype has the same sliding feature to reposition every control interface to any place alongside the backrest's edge. This is very useful for users with need of joystick input in a position different from the armrest, or that ones who will use head movements with switch interfaces.

Figure 3: detail of the control interface support structure and its adjustment.



Scanning control strategy

In the previous work, the scanning options contained four directions of movement distributed among the others control features. The original scanning sequence was: joystick input, move forward, move backward, turn right in the same place, turn left in the same place, follow right wall, follow left wall and use USB mouse input.

After the selection and execution of one of the functions, the options will follow the sequence previously mentioned. For example, after selection forward, the next option would be going backward.

This strategy had an odd result of being too slow to navigate, and one of the reasons is that a person usually moves forwards in a power wheelchair, making some left/right adjustments when needed. When selected the single switch input in our new system, the options of moving in the forward direction have more priority than the other ones. This simple feature was implemented in the new smart wheelchair as well in two patients adapted power wheelchairs. It was very clear that the time needed to select the desired options to move across a hall, or to get in and out of a room was shortened. In the figure below, the previous and new flowcharts of the scanning procedure are shown for comparison.

Figure 4: old scanning flow (left) and its new version (right) with enhanced possibilities for forward movement.

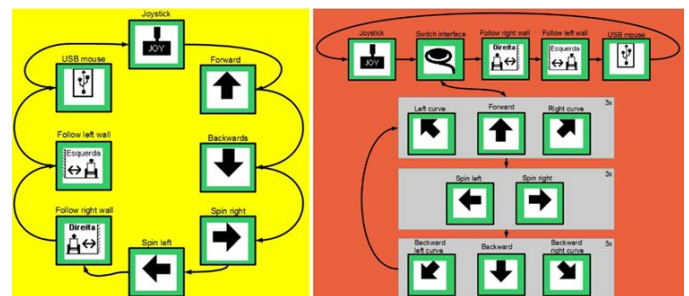

Results

From our previous work, 13 patients used the first smart wheelchair and one the new model. Those tests resulted in four distinct power wheelchairs adaptations, following the test-prescribe-adapt process. Table 1 below shows all the patients attended so far.

Patient	Age	Diagnostic	Control interface	Functional Segment
Patient 01	14	Cerebral Palsy	Single switch	hand
Patient 02*	10	Cerebral Palsy	USB mouse with switches	foot
Patient 03	16	Cerebral Palsy	Single switch	hand
Patient 04	13	Cerebral Palsy	Joystick	hand
Patient 05	16	Cerebral Palsy	USB mouse with switches	hand
Patient 06	8	Cerebral Palsy	USB mouse with switches	hand
Patient 07	43	Spinal cord injury	Single switch	chin
Patient 08*	29	Spinal cord injury	USB mouse for tongue	mouth/tongue
Patient 09	10	Artrogriposis	Joystick	hand
Patient 10	9	Artrogriposis	Joystick	hand
Patient 11	13	Cerebral Palsy	Joystick	hand
Patient 12	34	Traumatic brain injury	USB mouse with switches	hand
Patient 13	38	Traumatic brain injury	Joystick	chin
Patient 14	13	Artrogriposis	Joystick	foot
Patient 15	11	Cerebral Palsy	USB mouse with switches	hand
Patient 16	49	Polio	USB mouse with switches	hand
Patient 17	33	Spinal cord injury	USB mouse for lips	mouth/tongue
Patient 18	34	Traumatic brain injury	Joystick	hand
Patient 19	32	Spinal cord injury	Joystick	chin
Patient 20	23	Spinal cord injury	Joystick	chin
Patient 21*	29	Traumatic brain injury	Single switch	hand
Patient 22	13	Traumatic brain injury	Single switch	head
Patient 23	36	Traumatic brain injury	Joystick	hand
Patient 24	49	Spinal cord injury	Joystick	chin
Patient 25	10	Spinal cord injury	Joystick	hand
Patient 26	16	Cerebral Palsy	Joystick	chin
Patient 27	34	Cerebral Palsy	Joystick	chin
Patient 28*	21	Cerebral Palsy	Single switch	head
Patient 29	53	Spinal cord injury	Joystick	chin
Patient 30	11	Cerebral Palsy	Single switch	head
Patient 31	9	Genetic Disorder	Joystick	hand

Table 1: list of patients that tested both versions of the smart wheelchair.

The four persons that had their wheelchair adapted are marked with “*” and the last patient did the test in the new smart wheelchair. The most common used control interface is still a joystick, and the most used functional segment is the hand. But, single switches and USB mice are very used also, as well the chin and head as functional segments.

Conclusions

The first smart wheelchair that we presented at ISS 2015 was already a very good platform to test and prescribe power wheelchairs. But the seating features were limited to support an adult. The new design can be fitted both to children and adults.

The new project has permitted an easier testing by the clinical team, without losing any of the previous features that had already worked. With the enhanced seating features, a better input positioning and improved control strategies, we expect great results in using the smart wheelchair in our routine.

References

- Baldassin, V., & Gonçalves, C. (2015). Low cost smart-wheelchair for multiple input testing. In Proceedings of the 31st International Seating Symposium (p. 185–187). Nashville, TN.
- Carlson, T., & Demiris, Y. (2012). Collaborative control for a robotic wheelchair: evaluation of performance, attention, and workload. *IEEE transactions on systems, man, and cybernetics. Part B*, 42(3), 876–88. <http://doi.org/10.1109/TSMCB.2011.2181833>
- Edmy, R., Buitrón, C., Isidro, J., Melo, G., Carlos, J., & Jaramillo, B. (2015). Technological Adaptation of an Electric Wheelchair, Applying a Modular Approach. *Revista Politécnica*, 11(21), 57–74.
- Leishman, F., Horn, O., & Bourhis, G. (2010). Smart wheelchair control through a deictic approach. *Robotics and Autonomous Systems*, 58(10), 1149–1158. <http://doi.org/10.1016/j.robot.2010.06.007>
- LoPresti, E. F., Sharma, V., Simpson, R. C., & Mostowy, L. C. (2011). Performance testing of collision-avoidance system for power wheelchairs. *The Journal of Rehabilitation Research and Development*, 48(5), 529. <http://doi.org/10.1682/JRRD.2010.01.0008>
- Montella, C., Pollock, M., Schwesinger, D., & Spletzer, J. (2012). Stochastic Classification of Urban Terrain for Smart Wheelchair Navigation. Proc. of the IROS Workshop on Progress, Challenges and Future Perspectives in Navigation and Manipulation Assistance for Robotic Wheelchair.
- Montesano, L., Minguéz, J., & Marta, D. (2009). Towards an Intelligent Wheelchair System for Cerebral Palsy Users. *IEEE Transactions on Neural Systems and Rehabilitation Engineering*, 18(2), 193–202. <http://doi.org/doi:10.1109/tnsre.2009.2039592>
- Rofer, T., Mandel, C., & Laue, T. (2009). Controlling an automated wheelchair via joystick/head-joystick supported by smart driving assistance. 2009 IEEE International Conference on Rehabilitation Robotics, 743–748. <http://doi.org/10.1109/ICORR.2009.5209506>
- Simpson, R. C. (2005). Smart wheelchairs: A literature review. *The Journal of Rehabilitation Research and Development*, 42(4), 423. <http://doi.org/10.1682/JRRD.2004.08.0101>
- Simpson, R. C. (2008). How many people would benefit from a smart wheelchair? *The Journal of Rehabilitation Research and Development*, 45(1), 53–72. <http://doi.org/10.1682/JRRD.2007.01.0015>

PS5.2: A Global Description of Wheelchair Service Education

Paula W. Rushton, OT, PhD

Karen H. Fung, MS

Rachel Gartz, BS

Mary Goldberg, PhD

Maria L. Toro Hernandez, PhD

Nicky Seymour, OT, M.Phil

Jonathan Pearlman, PhD

¹School of Rehabilitation, Université de Montréal, Montreal, Quebec, Canada; ²Marie Enfant Rehabilitation Center, Sainte-Justine University Hospital Research Center, Montreal, Quebec, Canada; ³Rehabilitation Science & Technology, University of Pittsburgh, Pittsburgh, Pennsylvania, USA; ⁴Human Engineering Research Laboratories, Department of Veterans Affairs, Pittsburgh, Pennsylvania, USA; ⁵Department of Physiotherapy, Universidad CES, Medellin, Antioquia, Colombia; ⁶Motivation Charitable Trust, Cape Town, Western Cape, South Africa

Introduction

There is an estimated 70 million people with disabilities who need wheelchairs, 20 million of whom do not have one.^{1,2} For individuals with disability, poorly fitting or inappropriate wheelchairs can put them at risk for secondary injuries and high likelihood of abandoning the technology. Wheelchair service provision from trained rehabilitation professionals can help to alleviate those risks. In 2008, the World Health Organization (WHO) proposed an 8-step wheelchair service provision model with the goal of providing people with disabilities access to appropriate wheelchair service, regardless of resource setting.³ The 8-step model includes (1) referral and appointment, (2) assessment, (3) prescription, (4) funding and ordering, (5) product preparation, (6) fitting, (7) user training, and (8) maintenance, repairs, and follow up.³ The WHO later developed the Wheelchair Service Training Packages (WHO WSTP) based on the 8-step model as an open access resource to teach the provision of appropriate wheelchair service.

One aim of the International Society of Wheelchair Professionals (ISWP) is to raise awareness of and to facilitate the integration of the WHO 8-step model into professional rehabilitation programs around the world. With more professionals trained in appropriate wheelchair service provision, more wheelchair users around the world will receive the adequate wheelchair service, which in turn, leads to better quality of life.

To determine the needs and to inform the development of integration tools, the ISWP conducted a survey to gain an enhanced understanding of the current wheelchair service education provided in professional programs.

Methods

Design

This study used a cross-sectional survey design. This project was approved by the Institutional Review Board at the University of Pittsburgh.

Sample and Recruitment Procedure

A convenience sample of respondents representing educational institutions worldwide was recruited through the ISWP listserv, which included individual university contacts and professional networks, followed by snowball sampling. The invitation to participate and the link to the online survey were sent via email with recruitment lasting between August 2015 and September 2015.

Data Collection and Analyses

A survey of 27 questions was developed by the ISWP and distributed using Survey Monkey. It was designed to collect data on 3 types of respondents: A) those using originally developed wheelchair material, B) those using WHO WSTP and other existing resources and C) those who are not currently teaching wheelchair service provision content, but are interested in doing so. Quantitative responses were analyzed through summary statistics and reported in fractions of answers per respondents of each question. Qualitative answers were analyzed by content analysis. When relevant, educational institutions were stratified into low resourced settings, upper-middle resourced settings, and high resourced settings based on the World Bank categories.⁵

Results

Seventy-two representatives from educational institutions in 21 countries of different economic standings completed the survey. Of the respondents, 11/72 were from low resourced settings, 12/72 from upper-middle resourced settings and 49/72 from high resourced settings. Wheelchair content was taught in ~79% of represented institutions. However, there is great variability in what and how it is taught and how it is evaluated. Of the educational institutions that teach wheelchair-related topics, 75% of respondents indicated their use of originally developed course material, 10% respondents used WHO WSTP and 15% respondents used other available resources, such as the Wheelchair Skills Program. In comparison to the recommended duration of 40 hours of the WHO WSTP course, 82% of educational institutions teaching with their own wheelchair-related course material taught 20 hours or less. Moreover, in terms of pedagogical methods, 66% of original wheelchair-related course material included practicum, while the WHO WSTP incorporates practicum in its course based on the WHO 8-step model. Of the 15 respondents that did not include wheelchair service provision education, all but one expressed an interest to integrating wheelchair-related education into their professional rehabilitation curricula in their educational institutions.

Discussion

This is the first study to examine the current state of wheelchair service provision education in academic rehabilitation programs worldwide. The degree of inclusion of wheelchair content related to all 8 steps of the WHO model is variable, thus supporting the need for a more standardized approach. The survey results have informed the development of integration tools to facilitate the use of the WHO 8-step model to guide educational curricula, with the ultimate goal of improving the quality of wheelchair service provision worldwide.

Funding/Support

This project was funded by JSI Research and Training Institute and the US Agency for International Development (APC-GM-0068).

References

1. Guidelines on provision of manual wheelchairs in less resourced setting (rep. No. ISBN 978 92 4 154748 2), (2008). Retrieved June 9, 2016, from WHO Press website: <http://www.who.int/disabilities/publications/technology/wheelchairguidelines/en/>
2. Sheldon, S. Jacobs N.A., eds Report of a Consensus Conference on Wheelchairs for Developing Countries, Bangalore, India, 6-11 November 2006. (2007). Retrieved June 9, 2016 from International Society for Prosthetics and Orthotics website: http://www.who.int/disabilities/technology/Wheelchair_full_report.pdf
3. Toro, M. L., Eke, C., & Pearlman, J. (2015). The impact of the World Health Organization 8-steps in wheelchair service provision in wheelchair users in a less resourced setting: A cohort study in Indonesia. *BMC Health Services Research* *BMC Health Serv Res*, 16(1). doi:10.1186/s12913-016-1268-y
4. World Report on Disability (Rep. No. ISBN 978 92 4 068521 5). (2011). Retrieved June 9, 2016, from WHO Press website: http://www.who.int/disabilities/world_report/2011/en/
5. THE WORLD BANK GROUP (2016). World Bank Country and Lending Groups. Retrieved August 16, 2016, from The World Bank Group website: <https://datahelpdesk.worldbank.org/knowledgebase/articles/906519>

Address of contact person:

Paula Rushton, OT, PhD
Assistant Professor
Université de Montréal, École de réadaptation
Centre de Réadaptation Marie Enfant, CHU Sainte-Justine
5200, rue Bélanger Est
Montréal, Québec
H1T 1C9

Disclosure

We (**Paula W Rushton, Karen H Fung, Rachel Gartz, Mary Goldberg, Maria L Toro, Nicky Seymour & Jonathan Pearlman**) do not have an affiliation (financial or otherwise) with an equipment, medical device or communications organization.

PS5.3: Development of an Online Wheelchair List for Wheelchair Users (Intermediate)

Anand Mhatre, MIMSE

Introduction:

In less-resourced settings, inappropriate wheelchairs are delivered that do not match user needs and perform poorly outdoors. Provision of appropriate and reliable wheelchairs requires consumers and providers to be informed regarding product features, quality and field performance. Consumer Reports is a resource that provides similar information with evaluation of consumer products but there is no such source of information on wheelchairs delivered in less-resourced settings.

Aim:

Recognizing the aforementioned issue, the development of an online wheelchair catalog that provides relevant information to users and providers during delivery was undertaken.

Methods:

Prior to development, the functional requirements of the catalog were brainstormed and design specifications were developed accordingly. Following design and internal review of wireframes, a prototype was developed on Drupal Gardens – a content management system. Reviews were obtained on the prototype from 2 clinicians from less-resourced countries and 5 wheelchair experts. After incorporating their suggestions, a final version of the prototype was developed and feedback was received from 7 wheelchair manufacturers and 1 service provider who provide chairs in less-resourced settings.

Results:

The first prototype (<http://wheelchairnation.drupalgardens.com/>) was developed based on initial specifications. Clinicians and wheelchair experts appreciated the prototype and mentioned they would like to see more chairs from their region in the catalog. Including guidelines on wheelchair usage and maintenance, details about government schemes for wheelchairs and functionality to match wheelchair features to user conditions and needs were some of the other suggestions. Wheelchair experts favored the feature of online user reviews and recommended provision of ratings and reviews through SMS for users who cannot access the internet. This functionality was incorporated in developing the final version as Seating and Mobility Product List available

at <http://wheelprogress.org/>. Manufacturers favored the development and mentioned that user and clinician reviews should be indicative of outdoor wheelchair performance which should assist in product optimization.

Conclusions:

Our catalog informs about product quality through test reports, allows users and providers to communicate with manufacturers for product issues and provide wheelchair reviews which is not available currently in less-resourced settings. Social media tools should enable user's participation in the community. Reviews from different user groups ascertained that various features of our catalog should assist in making informed choices during provision. The iterative design and review approach has assisted in developing a solution that needs to be trialed with wheelchair consumers in the less-resourced communities. This background work was necessary to carry out future research on evaluating effectiveness of the catalog for provision of appropriate wheelchairs. Such a resource can empower wheelchair users in less-resourced settings for participating actively in the wheelchair provision process and assist in delivery of appropriate wheelchairs.

PS5.4: Evaluating the Effectiveness of Hybrid Wheelchair Training

A. Yohali Burrola Méndez, MS, PT
Mary Goldberg, PhD
Francisco Bonilla-Escobar
Virginia Brown
Jonathan Pearlman, PhD

Background

The World Health Organization (WHO) estimates that 15% of the global population lives with disabilities (World Health Organization, 2011). Approximately, 10% (75 million people) require a wheelchair for mobility and function and only 5-15% have access them (Frost, Mines, Noon, Scheffler, & Jackson, 2012; World Health Organization, 2016). Almost 80% of the people with disabilities live in low-income countries where government funding for the provision of wheelchairs is rarely available (World Health Organization, 2016).

International charities and non-governmental organizations (NGOs) have been the primary source of wheelchair provision through regional distribution points in less-resourced settings (Pearlman, Cooper, Zipfel, Cooper, & McCartney, 2006; World Health Organization, 2016). Studies have shown that donated wheelchairs often do not meet wheelchair users' needs due to untrained personnel distributing them and providing additional services (Mukherjee & Samanta, 2005; World Health Organization, 2016). The lack of trained personnel results in wheelchair donations without appropriate services such as assessment, prescription, fitting, user training, and follow-up which often results in poorly fitted wheelchairs that are difficult to propel, failure prematurely, and in some cases injure the user (World Health Organization, 2016). The impact of an inappropriate wheelchair can cause secondary health conditions such as pressure ulcers, postural deformities, and restricted breathing and range of motion (World Health Organization, 2016).

In 2012, the WHO in partnership with the United States Agency for International Development (USAID) published the Wheelchair Service Training Package Basic Level (WSTPb) (Frost et al., 2012). The purpose of the WSTPb is to develop the skills and knowledge required by personnel delivering basic level wheelchair services to people with mobility impairments who can sit upright without additional postural support. The WSTPb allocates 40 hours of training spread over five consecutive days.

Despite the launch of the WSTPb in 2012, the training materials are in limited use, in part because the intervention requires a 5-day in person course which is challenging for many to attend and costly to run. To address this need, the

International Society of Wheelchair Professionals (ISWP) developed a blended course, a combined online and in-person training, called the Hybrid Training Course. The purpose of this study was to examine the effectiveness of hybrid training course as an alternative learning methodology to increase knowledge in basic level wheelchair delivery in a sample in Bangalore, India.

Methods

Study design

This quasi-experimental controlled trial of basic level wheelchair knowledge utilized a pre- and post-assessment design to compare an in-person training course against a hybrid course (online and in-person training) carried out in February and May of 2016, respectively, in Bangalore, India.

The experimental group underwent the hybrid training program that allocates the knowledge component of the training in online modules and 24 hours of in-person training distributed over a three-day period. The control group followed the standard learning methodology proposed by the WHO of 40 hours of in-person training, spread over a five-day period.

Study population

The sample was selected using a convenience sampling method. Strategic partnerships were established with local organization; Mobility India (MI) conducted the in-person training in February 2016, and Specialized Mobility Operations and Innovations (SMOI) conducted the hybrid in May 2016. Organizations followed the same recruitment technique; they distributed flyers and word-of-mouth advertisement. As inclusion criteria, we considered clinicians who work in wheelchair service delivery at their own settings who have not taken the WSTPb nor the ISWP Basic Test. We excluded participants who did not complete the pre or post assessment outcome measure or the training intervention. Participant's knowledge was measured by the ISWP Basic Test before and after the intervention.

Instruments and outcome assessment

The ISWP - Basic Test is a valid and reliable method for measuring basic competency of wheelchair professionals (Gartz et al., 2016). The test consists of two sections: sociodemographic questionnaire and wheelchair knowledge test. The sociodemographic questionnaire included age, gender, years of experience providing wheelchair services, previous wheelchair trainings, education degree, employment status, motivation, hours dedicated to served wheeled mobility, age group served, and membership of professional organizations. The wheelchair knowledge section consisted of 75 multiple choice questions that evaluate seven domains of wheelchair delivery: assessment, prescription, fitting, production, user training, process, and follow-up and maintenance (Gartz et al., 2016). The passing grade was considered as a score greater or equal than 53 points which represent a 70% of total answers. The test was distributed using Test.com®. Participants received an email with the instructions on how to login to the testing platform and how to take the test 1-week prior and 1-week after (post) the intervention.

The main outcome of the study was the difference between post and pre-assessments compared by group following a between subjects design (hybrid vs. in-person training). The secondary outcome was the differences between post and pre-assessment within subjects in each group of study.

Intervention

The in-person training followed the methodology proposed by the WHO in the WSTPb. This approach allocates the 40 hours of training spread over five consecutive days. As recommended by the WHO, trainers were skilled in basic level wheelchair service delivery and have previous experience as trainers of the WHO WSTPb package.

The hybrid training course is a combined online and in-person training developed by ISWP. The online portion allocates the core knowledge component in eight interactive online modules. The modules were developed in Adobe Captivate 9®. The content of each module strictly followed the objectives, resources, activities and outlines of the WSTPb. No additional materials or modification of the original content was made. The modules were hosted in Coursesites by Blackboard®, a free learning platform available for students and professors via the Internet 24/7. The eight modules, were proportionally distributed in two section, participants had six days to review each section asynchronously. Two synchronic recitations were conducted, the first after the completion of the first four modules and the second after the completion of the last module. In the recitation, trainers responded to participants' questions and reinforced the key points of each module. Two days after the recitation, participants underwent the 24 hours of in-person training distributed in three consecutive days. The in-person training followed the methodology proposed by the WHO.

Statistical methods

All of the data was collected in a Test.com® database and was exported into a CVS file and then into Stata 14® (StataCorp, TX). Frequency, percentage, central tendency and dispersion measures were carried out for categorical and continuous variables, respectively. The groups were compared using chi2 or Fisher's exact test for categorical variables, or t-test with equal or unequal variances in agreement with the variance ratio test of Stata®.

The results of the knowledge test were compared among the subjects per group with a paired t-test. The comparison between the two groups was carried out creating a variable that accounts for the difference between the pre and post assessment (difference=post-pre). This variable was compared between the two groups (control and intervention) using an unpaired t-test with unequal variances. Linear regression models to identify the relation between the scores (pre, post, difference) and the arms adjusted by age (baseline difference between the groups) were built. Their significance was assessed to understand the effect of the differential distribution of age among the groups in the results. Furthermore, a sensitivity analysis of one (1) outlier in the age variable (>2 standard deviations) was carried out to assess its effects in the results, by removing it from the analysis. All the statistical analysis used an alpha level of 0.05.

This study used standard educational according to 45 CFR 56.101(b)(1) of research that involves normal educational practices and thus is Exempt from IRB review. Confirmation of this exemption is currently being sought from the University of Pittsburgh's IRB and will be in place by the time of ISS.

Results

A total of 47 participants were recruited, 8 participants (17.02%) were excluded, 5 (62.5%) from the in-person and 3 (37.5%) from the hybrid course ($p=0.7$). There was no statistical difference between the excluded and non-excluded participants based on the variables of the study ($p>0.05$).

A total of 39 (83%) participants completed the pre and post assessments, 20 (51.3%) from the in-person training and 19 (48.7%) from the hybrid training (Figure 1). Participants' characteristics and their distribution among the study groups are described in Table 1; only age was found as a significantly different variable; the population of the hybrid training was younger compared with the in-person course (t-test with equal variances, $p=0.001$).

The average scores in the in-person program and the hybrid training based on the pre-assessment, post-assessment, and their difference are described in Table 2. In each group, the difference within participants in their pre and post assessments was significant, with an average increase in the score of 14.9 ± 9.5 in the in-person group ($p<0.0001$) and 12.6 ± 5.2 in the hybrid group ($p<0.0001$). However, there were no statistically significant differences between the groups regarding the main (difference) and secondary outcomes (pre and post assessments). On the other hand, there was no difference in the passing score of the participants and the groups ($p>0.05$).

Age was analyzed as a potential confounding variable. The linear regression assessing the relation between the pre and post scores including their difference by group and age did not report association with the changes in the scores as described in Table 3, except the pre assessment in the hybrid group, where older ages showed better performance (Figure 2); however, the average scores between the two groups were not different ($p=0.9$). Further, the linear regression models for each score (pre, post, and the difference) adjusted by group and age were not statistically significant (F: $p=82$, $p=0.42$, and $p=0.15$, respectively); therefore, the age differences between the groups did not affect the lack of statistically significant difference in the scores between the in-person and the hybrid training.

Finally, an outlier value was found in age. It was a female participant who was 60 years of age, with 0 to 1 year of experience working with wheelchairs, more than 8 years after her last training, with a high school degree, without previous trainings, and less than 3 hours of direct services of wheeled mobility. Removal of the outlier from the analysis did not affect the main outcome (difference between post and pre-assessments compared by group: in-person 15.8 ± 8.8 , hybrid 12.6 ± 5.2 , $p=0.19$) or the secondary outcomes (differences between post and pre-assessments within a group, in-person: 15.8 ± 8.8 , $p<0.001$; hybrid: 12.6 ± 5.2 , $p<0.001$).

Discussion

This study aimed to test the effectiveness of the ISWP Hybrid Training Course in increasing knowledge in basic level wheelchair service delivery. Both groups reported a statistically significant increase in post scores after the intervention ($p < 0.0001$), and there were not statistically significant differences between groups which demonstrates that the Hybrid Training Course is as effective as the in-person methodology in increasing knowledge in basic level wheelchair provision in a population in Bangalore, India.

Limitations

Although pilot studies represent a fundamental phase of the research process to examine the feasibility of an approach that is intended to be used in a larger scale study, there are important limitations in this study that need to be considered. First, we studied two sample populations in Bangalore, India, and our findings may not be generalizable to other groups in other low-income countries. Nevertheless, having a control group from the same region allow us to compare our intervention with the standard of training. Second, the WHO methodology suggests a group size no bigger than twenty participants for this training to increase the likelihood of two equivalent groups that only differ in the learning methodology. We respect the group size which impacted the size of our sample. Third, the used of a convenient sampling method makes our study highly vulnerable to selection bias and undermines the ability to generalize from our sample to the population.

Conclusion

The pilot of the Hybrid Training Course proved to be as effective as the in-person training in increasing knowledge in basic level wheelchair service delivery in a pilot study conducted in Bangalore, India. As next steps, researchers will need to replicate this study in other low-income settings, randomize participants to interventions and increase the size of the sample.

References

1. Frost, S., Mines, K., Noon, J., Scheffler, E., & Jackson, R. (2012). Wheelchair Service Training Package Basic level.
2. Gartz, R., Goldberg, M., Miles, A., Cooper, R., Pearlman, J., Schmeler, M., ... Hale, J. (2016). Development of a contextually appropriate, reliable and valid basic Wheelchair Service Provision Test. *Disability and Rehabilitation: Assistive Technology*, 1–8. <https://doi.org/10.3109/17483107.2016.1166527>
3. Mukherjee, G., & Samanta, A. (2005). Wheelchair charity: a useless benevolence in community-based rehabilitation. *Disability and Rehabilitation*, 27(10), 591–6. <https://doi.org/10.1080/09638280400018387>
4. Pearlman, J., Cooper, R., Zipfel, E., Cooper, R., & McCartney, M. (2006). Towards the development of an effective technology transfer model of wheelchairs to developing countries. *Disability and Rehabilitation*, 1(1–2), 103–110.
5. World Health Organization. (2011). WHO | World report on disability. WHO. Retrieved from http://www.who.int/disabilities/world_report/2011/en/
6. World Health Organization. (2016). WHO | Guidelines on the provision of manual wheelchairs in less-resourced settings. WHO. Retrieved from <http://www.who.int/disabilities/publications/technology/wheelchairguidelines/en/>
- 7.

Figure 1. Recruitment Flow diagram of the study

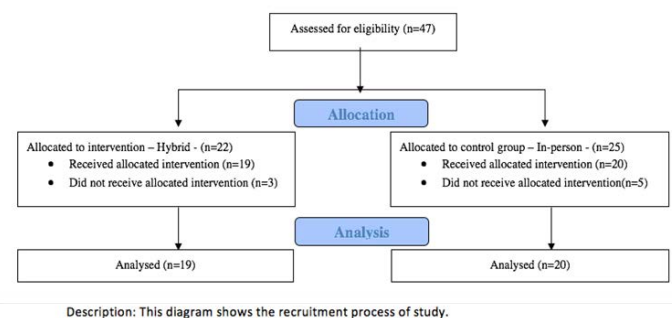

Figure 2. Distribution of scores based on age of participants

Description: This graphic describes the relation between the age of participants and their pre scores and the differences between post and pre assessment of each group.

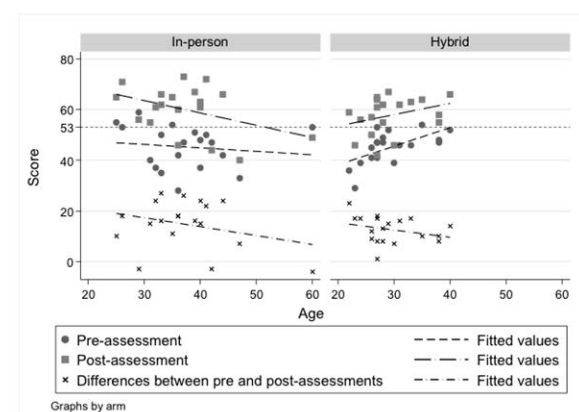

Table 1. Characteristics of the study population in agreement with their group of training.

Description: The table describes study population characteristics per group and total population.

It includes p values for specific comparison between groups.

Characteristic	In-person (n=20)	Hybrid (n=19)	Total (n=39)	p
Age [mean (SD)]	37.1 (1.8)	29.4 (1.2)	33.3 (7.7)	0.001 [†]
Sex: Male [n (%)]	11 (52.4)	10 (47.6)	11 (53.8)	0.9 [†]
Educational level				
Bachelor or less	7 (50)	7 (50)	14 (35.9)	0.9 [†]
Master degree	13 (52)	12 (48)	25 (64.1)	
Employment status				
20 hours/week	1 (33.3)	2 (66.7)	3 (7.7)	0.1 [‡]
40 hours/week	19 (57.6)	14 (42.4)	33 (84.6)	
Unemployed	0 (0)	3 (100)	3 (7.7)	
Experience providing wheelchair services (n(%))				
0-1 year	8 (40)	12 (60)	20 (51.3)	0.6 [‡]
2-3 years	3 (60)	2 (40)	5 (12.8)	
4-7 years	5 (62.5)	3 (37.5)	8 (20.5)	
8 or more years	4 (66.7)	2 (33.3)	6 (15.4)	
Previous wheelchair courses	7 (70)	3 (30)	10 (25.6)	0.3 [‡]
Time since the last educational training				
0-1 years	6 (33.3)	12 (66.7)	18 (46.1)	0.06 [‡]
2-3 years	1 (25)	3 (75)	4 (10.3)	
4-6 years	4 (80)	1 (20)	5 (12.8)	
7-8 years	1 (50)	1 (50)	2 (5.1)	
More than 8 years	8 (80)	2 (20)	10 (25.6)	
Hours of direct service to wheeled mobility				
Less than 3 hours	9 (64.3)	5 (35.7)	14 (35.9)	0.09 [‡]
3-10 hours	5 (31.3)	11 (68.7)	16 (41)	
11-20 hours	3 (100)	0 (0)	3 (7.7)	
21 or more hours	3 (50)	3 (50)	6 (15.4)	
Member of a professional organization	16 (61.5)	10 (38.5)	26 (66.7)	0.07 [†]

†. T-test; †. Chi2; ‡. Fisher's exact test.

the passing grades and the p values for comparison based on group studies.

Test	In-person (n=20)	Hybrid (n=19)	p-value
Pre assessment score [mean (SD)]	44.8 (8.6)	45.2 (6.3)	0.9 [*]
Passing the test [n (%)]	5 (71.4)	2 (28.6)	0.4 [*]
Post assessment score [mean (SD)]	59.7 (9.4)	57.8 (7.3)	0.5 [*]
Passing the test [n (%)]	16 (51.6)	15 (48.4)	1.0 [*]
Difference within post-pre [mean (SD)]	14.9 (9.5)	12.6 (5.2)	0.4 ^{**}

*. T-test with equal variances. **. T-test with unequal variances. †. Fisher's exact test.

Table 3. Relation of age and participants' scores based on the groups of training.

Description: This table describes the relation between scores and age in a linear regression model adjusted by group and age. Slope, confidence interval, goodness of fitness and p values from each group are included.

Assessment	In-person			Hybrid		
	β_{age} (95%CI)*	R ²	p-value	β_{age} (95%CI)*	R ²	p-value
Pre	-0.14 (-0.67;0.40)	1.6%	0.6	0.73 (0.22-1.24)	35.7	0.007
Post	-0.49 (-1.04;0.06)	17%	0.08	0.45 (-0.24;1.13)	10%	0.19
Difference	-0.35 (-0.94;0.24)	8.5%	0.23	-0.29 (-0.78;0.21)	8%	0.24

*Linear regression model adjusted by age and group.

IC41: CARF Accreditation in Assistive Technology

Dawn Hameline, OTR/L, ATP
Melissa Oliver, MS, OTR/L

Learning Objectives:

Participants will describe 3 different methods for demonstrating conformance to the standards.
Participants will state the importance of the ASPIRE section of the survey.
Participants will identify 2 different resources within their organization that may assist them in conformance to standards.
Participants will identify a resource to assist in survey preparation and organization.

Abstract

CARF –the Commission on Accreditation of Rehabilitation Facilities is considered the gold standard, the premier accrediting body for rehabilitation programs. Accreditation assures the public that you have made a commitment to quality program improvement and focus on client satisfaction. To be CARF accredited, you must meet stringent international standards demonstrating quality, value, optimal outcomes and continued service enhancement.

In 1998, accreditation opportunities in assistive technology first became available. CARF believes that an organization providing a wide array of employment and community assistive technology services can support persons and families in making informed decisions and choices, thus increasing employment options, independence and community inclusion & interdependence.

The decision to seek CARF Accreditation is voluntary. The survey can be stand alone, for a single program/service area or be blended to include services in more than one standards manual. The process for application generally takes 9-12 months of preparation. Each program or service needs to implement and operate in conformance to the outlined standards for a minimum of 6 months prior to survey.

To begin, your program would obtain a copy of the CARF Employment and Community Service Standards Manual. The focus on AT is currently in section 3Q – Assistive Technology Supports and Services. This manual serves as a basic reference identifying standards for program accreditation. CARF standards define the expected input, processes and outcomes of programs for persons served.

Some standards in AT include promoting universal design principles, program scope, client participation, individualized service plans, environmental awareness and community collaboration. Other, standards are also required, including the ASPIRE to Excellence® framework for quality improvement. In this framework, CARF provides business

practice standards using an action-oriented approach to ensure the integration of all organizational functions and input from stakeholders to achieve desired outcomes.

Demonstration of conformance is what the surveyors will be looking for. You need to be asking yourself ‘how do I show that we do this?’.

Conformance to standards can be measured through observation, interview or through written documentation. It must be readily available to surveyors. CARF Appendix A lists standards that explicitly require some form of written evidence in order to achieve full conformance. CARF Appendix B lists CARF standards that require activities be conducted at specific time intervals. A survey preparation handbook is also available that may be useful in preparing for the interview portion of the survey. |

CARF survey preparation takes time and dedication. This session is designed for those pursuing or considering CARF accreditation in Assistive Technology Supports and Services.

References:

CARF. 2015. 2015 Employment and Community Services Standards Manual. Tucson, AZ: CARF Medical Rehabilitation Standards Manual (Appendix D, pp. 1-13, Rep.). (2016).
Gavin, J. C., & Langton, A. J. (n.d.). Designing and Delivering Quality Assistive Technology Services (Rep.). Tucson, AZ.

IC42: Documentation for Complex Rehab Technology: The Ethical Dilemma

Weesie L. Walker, ATP/SMS

Chris Maurer, MPT, ATP

Documenting medical necessity for Complex Rehab Technology(CRT) is one of the most important components in the evaluation process. Technology is matched to the consumer's needs and justified based on the physical examination. As we know, the evaluation process is a team effort. The supplier and the clinician have specific roles which are outlined in the RESNA Standard of Practice, NRRTS Code of Ethics and Wheelchair Service Provision Guide.

Depending on the experience and knowledge of the clinician, the supplier's role will vary during the CRT evaluation process. For instance, in a seating clinic setting, the clinician will have more equipment knowledge and understanding of funding. Outside of a clinical setting, the clinician may not be experienced in participating in CRT provision and the supplier will direct more of the process.

This can create a dilemma for the supplier when it comes to completing the required documentation for the medically necessary equipment. Letters of Medical Necessity, or "LOMN's", no longer exist. Funding agencies are looking for the therapy assessment along with the equipment justification based on the findings in the therapy (physical/ functional/ environmental) assessment typically performed by the therapist. In some cases, the supplier may see a need to create the medical justification as the easiest or only path to completing the documentation, especially if the therapist does not feel he/ she has the skills to do so. This is not in the best interest of the consumer and against the practice standard. The supplier is now crossing the line. Not only is it a conflict of interest, it may not meet all the needs of the consumer or be accurate. The supplier will need a strategy for guiding the clinician so that the best outcome is possible for the consumer.

This presentation will outline the clinician's obligation to the consumer in the documentation process. By understanding the role of the clinician, the supplier can provide guidance on the specifics of justifying CRT. Strategies will be provided to assist the supplier in educating and clearly and directly communicating with the evaluating therapist his/her part in the justification process.

IC43: Overcoming Barriers to Best Practice: Keep the Client First!

Ginger Walls, PT, MS, NCS, ATP/SMS

Learning Objectives

- Identify 2 barriers to end-users' access to technology and discuss 2 options of how to overcome them.
- Summarize 3 key points from research about power seat function utilization and discuss 2 possible clinical/equipment recommendations to improve utilization of power seat functions.
- List 3 examples of linking clients' needs with technology recommended in clinical documentation.

Discussion

Clinicians and providers are challenged to find their way to 2017 best practice recommendations in an industry where innovations in technology are far outpacing advances in funding. Education on options, choices, and how to navigate the complex CRT and health care environment is an important skill set of the CRT Team. Clients' independence is on the line! Clinicians and providers must understand how to empower their clients with choices of the best rehab technology solutions for clients' long term health, function and participation - as well as to keep their practice current with today's technology that's available.

This presentation will apply client case studies on power seat function utilization for pressure injury management, as well as other health, functional activity, and participation goals, to illustrate the steps to best outcomes, including:

- identifying client needs
- identifying technology available to maximize outcomes
- understanding evidence about how technology is really used in every-day life
- identifying barriers to client access to technology
- charting a path to optimal recommendations
- and documenting so that individual client's needs are clearly linked with the technology recommended.

References:

1. Dicanno, B., Liberman, J., Schmeler, M., Schuler, A., Cooper, R., Lagne, M., Liu, H., Jan, Y. (2015). RESNA Position on the Application of Tilt, Recline, and Elevating Legrests for Wheelchairs: Literature Update, [position paper]. RESNA. Retrieved September 11, 2016 from http://www.resna.org/sites/default/files/legacy/resources/position-papers/RESNA%20PP%20on%20Tilt%20Recline_2015.pdf
2. Dicianno, B; Morgan, A; Lieberman, J; Rosen, L. (2013). RESNA Position on the Application of Wheelchair Standing Devices: 2013 Current State of the Literature, [position paper]. RESNA. Retrieved October 28, 2016 from http://www.resna.org/sites/default/files/legacy/resources/position-papers/RESNASTandingPositionPaper_Dec2013.pdf
3. Liu, H. (2013). Development of a Customized Electronic Reminder to Facilitate Powered Seating Function, Usage and Compliance with Clinical Recommendations: Design Process and Clinical Efficacy (Unpublished doctoral dissertation). University of Pittsburgh.
4. Sonenblum, S., Sprigle, S. (2011). Distinct tilting behaviors with power tilt-in-space systems. *Disability and Rehabilitation: Assistive Technology*, 6(6), 526-535.

IC44: Empowering Practice: Evaluating Seating and Mobility Outcomes

William C. Miller, PhD, FCAOT

Lisa Kenyon, PT, DPT, PhD, PCS

We (William Miller and Lisa Kenyon) do not have any conflicts of interest to disclose. Specially, none of the authors have an affiliation (financial or otherwise) with an equipment, medical device, or communications organization

Background:

Have you ever been told that equipment you have prescribed for a patient/client has been denied because of a lack of evidence? Given the ever increasing demands for evidence-based therapeutic outcomes, clinicians often grapple with how to effectively evaluate client-centered outcomes of seating and mobility interventions. Single-subject research designs (SSRDs) are a clinically oriented yet rigorous approach that allows clinicians to quantitatively evaluate and validate outcomes within their everyday practice. SSRDs also allow clinicians the opportunity to contribute to the professional knowledge base in a meaningful, purposeful manner.

Overview of Single-Subject Research Designs

An SSRD permits clinicians to study a single patient/client or a single system (e.g., a particular hospital, department, or program). An SSRD involves repeated measurement of a dependent variable (the target behavior or the effect that you are hoping to see) under rigorous, controlled conditions and systematic introduction of the independent variable (the seating or mobility intervention that you are providing). The intervention can also be withdrawn or varied depending on the particular type of SSRD being used. The SSRD uses the individual patient/client as his/her own control thereby not only accommodating specific client-related factors but allowing these factors to actually become part of the outcome assessment process.

research designs and from case reports: (1) Repeated, systematic measurement of the target behavior over time at regular, frequent intervals and (2) Use of design phases (baseline and intervention phases). The baseline (A) phase is a period of time without the intervention that reflects the patient/client's natural state and provides a standard for evaluating possible intervention effects. During the baseline phase, the target behavior (the effect that you are hoping to see) is measured repeatedly. Stability in the target behavior is ideally demonstrated during the baseline phase. From a rigor standpoint, a minimum of 5 measurements (data points) should be obtained during a baseline phase (Portney & Watkins, 2009). During the intervention (B) phase, the intervention (independent variable) is introduced. Repeated

measurement of the target behavior continues during the intervention phase. Ideally the intervention (B) phase should contain at least as many measurements (data points) as the baseline phase (Bloom, Fischer, & Orme, 2009; Portney & Watkins, 2009). Depending on the intervention being provided and how long it might take for the intervention to have an effect, there may be more data points in the intervention (B) phase than in the baseline (A) phase (Bloom et al., 2009; Portney & Watkins, 2009).

Identifying the target behavior (the effect that you are hoping to see) is an essential aspect of the SSRD. The target behavior must be quantifiable. It could be an overt behavior (such as functional performance of wheelchair skills), a physiological response (such as oxygen saturation levels), or a subjective report (such as pain). Measurement of the target behavior could be through use of a standardized test (such as the Wheelchair Skills Test (Kirby et al, 2016), but could also be through a frequency count of the behavior (the number of positive fascial expressions, number of self-abusive episodes, etc.).

Select Types Of Single-Subject Research Designs

There are numerous different types of SSRDs and a complete accounting of all of the various SSRD options is beyond the scope of this paper. A few of the more commonly used SSRDs are the Simple SSRD, Withdrawal Designs, Multiple Intervention Designs, and Multiple Baseline Designs. The Simple SSRD is an A-B design comprised of a single baseline (A) phase and a single intervention (B) phase. Let's say we wanted to explore the impact of a customized seating system on a patient/client's oxygen saturation levels. During the baseline (A) phase of the Simple SSRD, the target behavior (oxygen saturation level) is measured repeatedly until stability is reached. The intervention (the customized seating system) is then introduced and the target behavior (oxygen saturation level) is again measured repeatedly. Although it is a simple design, it is generally thought of as a weak design because a change in the target behavior (improved oxygen saturation levels) cannot be directly attributed to the intervention (the customized seating system) (Portney & Watkins, 2009).

This weakness can be addressed through replication: adding additional phases, repeating the SSRD across subjects, or by adding other interventions (Bloom et al., 2009; Portney & Watkins, 2009). A Withdrawal or A-B-A Design is comprised of a first baseline (A) phase, an intervention (B) phase, and a second baseline (A) phase. It allows clinicians to explore the effect of both introducing and removing the intervention thereby addressing the question: Is the change in the target behavior only noted in the presence of the intervention (Perdices & Tate, 2009; Portney & Watkins, 2009)? Continuing with our example of exploring the impact of a customized seating system on oxygen saturation levels this time using an A-B-A Design, the first baseline (A) phase and the intervention (B) phase would be carried out exactly the same as in the Simple SSRD above. In the A-B-A Design, however, use of the customized seating system during the intervention (B) phase would be followed by a second baseline (A) phase during which time the customized seating system would be withdrawn and no longer used. Measurement of oxygen saturation level (the target behavior) would continue during

this second baseline (A) phase. Ideally in this design, we would see improvements in oxygen saturation levels when the customized seating system was in use during the intervention (B) phase and a return to decreased levels of oxygen saturation once the customized seating system was no longer in use.

Withdrawal designs involving multiple iterations of the A-B sequence are also widely used. The A-B-A-B design provides two opportunities to evaluate the effect of the intervention. If the effects observed in the first intervention (B) phase can be replicated during a second separate intervention (B) phase, evidence of a causal relationship between the intervention and the target behavior is strengthened. Withdrawal Designs yield more favorable results when the target behavior readily returns to baseline levels. In contrast, Withdrawal Designs may be problematic when the target behavior is a learned behavior that theoretically cannot be unlearned or when the intervention results in sustained improvements that persist even after the intervention has been withdrawn (Bloom et al., 2009; Portney & Watkins, 2009). Another disadvantage of Withdrawal Designs relates to the ethical issues that must be considered when removing an intervention (Bloom et al., 2009; Lillie et al., 2011; Portney & Watkins, 2009).

Multiple Intervention Designs or A-B-C-A designs involve more than one intervention. In this design, B and C may represent either two different interventions or an intervention and a placebo. Continuing with our example to explore the impact of customized seating on oxygen saturation levels, perhaps we have two different customized seating systems that we evaluate: one in the B intervention and one in the C intervention. In multiple intervention designs, only adjacent phases can be compared (i.e., the first baseline (A) phase can only be compared to the B intervention and the C intervention can only be compared to the second baseline (A) phase (Portney & Watkins, 2009).

In Multiple Baseline Designs, effects are replicated across one of three entities: (1) Subjects, (2) Intervention conditions, or (3) Behaviors. Multiple Baseline Across Subjects Designs involve a single intervention that is applied across three or more patients/clients in the same setting. Varying the length of the initial baseline phase allows a staggered start to the intervention phase for each subject. The staggering baseline phases strengthens any causal relationship between the intervention and the target behavior as an effect would ideally be seen at different points in time with each subject (i.e., only when the intervention is introduced to each subject).

In a Multiple Baseline Across Intervention Conditions Design, one target behavior is evaluated on one subject using the same intervention across two or more environmental conditions (for example, at school and at home). Continuing with our example to explore the impact of a customized seating system on oxygen saturation levels, in a Multiple Baseline Across Intervention Conditions Design the baseline phase would start with the target behavior being repeatedly measured in all environmental conditions (both at school and at home in this example). After a baseline phase, use of the customized seating system (the intervention) would be introduced in one environmental condition (say at home) and oxygen saturation levels (the target behavior) would continue to be repeatedly measured in all environments (both at home and at school). At a later time, use of the customized seating system would be introduced in the second environment (at

school in this example) and repeated measurement of oxygen saturation levels (the target behavior) would continue in both environments (at home and at school). Ideally, such a design would result in improved oxygen saturation levels in each environment only after the intervention had been introduced in that environment (i.e., improved oxygen saturation levels at home only after the customized seating system is introduced at home and improved oxygen saturation levels at school only after the customized seating system is introduced at school).

In a Multiple Baseline Across Behaviors Design, a minimum of 3 similar yet functionally independent behaviors are evaluated in the same patient/client within the same setting using the same intervention. The baseline (A) phase starts with the target behaviors all being measured repeatedly. The intervention is then introduced in a staggered manner such that the intervention phase started at a different point in time for each behavior with repeated measurement of all of the target behaviors continuing across all phases. Ideally, such a design would result in a change in each target behavior only after the intervention had been introduced to address that particular target behavior.

Data Analysis in Single-Subject Research Designs

Historically, data analysis in SSRDs has relied primarily on graphing measurement (data) points and evaluating the data points using visual methods (Levin, Ferron, & Kratochwill, 2012; Nourbakhsh & Ottenbacher, 1984; Portney & Watkins, 2009). Additional data analysis techniques such as the two standard deviation band method are typically thought to be more rigorous and will be introduced at the conference (Levin et al., 2012; Nourbakhsh & Ottenbacher, 1984; Portney & Watkins, 2009).

Conclusions:

SSRDs are a valuable tool that allows clinicians to objectively evaluate seating and mobility outcomes within the context of everyday practice. SSRDs may also allow clinicians the opportunity to publish research findings thereby building evidence and strengthening practice within the essential area of seating and mobility interventions.

References:

1. Bloom, M., Fischer, J., & Orme, J.G. (2009). Evaluating practice: Guidelines for the accountable professional. Boston, MA: Pearson Publishers.
2. Kirby, R.L., Smith, C., Parker, K., McAllister, M., Boyce, J., Rushton, P.W., ... Brandt, A. (2016 March 7) The Wheelchair Skills Program manual. Retrieved from: www.wheelchairskillsprogram.ca/eng/manual.php.
3. Levin, J.R., Ferron, J.M., & Kratochwill, T.R.(2012). Nonparametric statistical tests for single-case systematic and randomized ABAB...AB and alternating treatment intervention designs: new developments, new directions. *Journal of School Psychology, 50*(5):599-624.
4. Lillie, E.O., Patay, B., Diamant, J., Issell, B., Topol, E.J., & Schork, N.J. (2011). The n-of-1 clinical trial: the ultimate strategy for individualizing medicine? *Personal Medicine, 8*(2):161-173.
5. Perdices, M., & Tate, R.L. (2009). Single-subject designs as a tool for evidence-based clinical practice: are they unrecognized and undervalued? *Neuropsychological Rehabilitation, 19*(6), 904-927.
6. Portney, L.G., & Watkins, M.P. (2009). *Foundations of clinical research: Applications to practice*. 3rd ed. Upper Saddle River, NJ: Prentice Hall Publishers.
7. Nourbakhsh, M.R., & Ottenbacher, K.J. (1984). The statistical analysis of single-subject data: a comparative examination. *Physical Therapy, 74*(8)768-776.

Please address correspondence to:

Dr. Kenyon at the following e-mail address:
kenyonli@gvvsu.edu

IC45: Seeing Opportunities for Success: Visual Factors for Positioning

Katherine Clark, MOT, OTR/L, ATP
Erin Pope, PT, MPT, ATP

Background

Cortical visual impairment (CVI) is a visual diagnosis commonly seen in patients with cerebral palsy and other neuro-motor disorders. Unfortunately, it is very common for patients to remain undiagnosed. Many of us have worked with patients who have atypical visual behaviors and functional deficits, but a “normal” eye exam. It can be frustrating to have no explanation for these deficits, particularly during assessment for mobility equipment. If you work with patients with neuro-motor disorders, it is likely you have worked with a patient with CVI – even if you have never heard of it. CVI can have a significant impact on the evaluation and selection of a positioning system. It is important that we consider the profound impact of visual function on posture and how this factors into successful use and tolerance of positioning equipment.

What is CVI?

CVI describes a condition where one is visually unresponsive but has a normal eye exam that cannot explain the significant lack of visual function (Roman-Lantzy, 2007). More specifically, CVI is a neurological disorder in which there is damage to the posterior visual pathways and/or the occipital lobes of the brain resulting in visual processing issues (Tallent, Tallent, & Bush, 2012). CVI is the leading cause of visual impairment of children in the United States and the First World, and is commonly seen in people with cerebral palsy (Good, Jan, Burden, Skoczinski, & Candy, 2001). In a recent review, CVI is noted as one of the three leading causes of childhood blindness in the United States (Kong, Fry et al. 2012). Though CVI is increasingly common, it is frequently missed because eye exams often focus on ocular structures and function. Thus someone may have a “normal” eye exam, but could still have CVI. A diagnosis of CVI can be given by an ophthalmologist or a neurologist, using these criteria:

1. Patient has a normal eye exam or an exam that reveals an eye condition that cannot explain the profound lack of functional vision,
2. Patient presents with a medical history of neurological problems,
3. Patient demonstrates presence of unique visual and behavioral characteristics (Roman-Lantzy, 2007).

It is important to note that approaches to treatment are vastly different when comparing ocular impairments to CVI. Ocular impairments may be treated with surgery or prescription of glasses. Although CVI cannot be corrected with glasses, functional vision can improve with rehabilitation if the patient

is stable and has a supportive team (Roman-Lantzy, 2007). Rehabilitation of functional vision requires providing supports, through adaptations in the setup of an environment or activities, to allow daily increased use of vision at a patient’s current level of function, with gradually increasing challenges. A patient’s functional vision can be measured through the CVI Range Assessment by Dr. Christine Roman-Lantzy, which measures the 10 unique visual and behavioral characteristics of CVI, and assigns a patient a score on a scale from 0 to 10 (Roman-Lantzy, 2007) based on severity. The 10 visual and behavioral characteristics of CVI are:

1. Color Preference- A strong attraction or increased response to visual targets of a specific preferred or bright color.
2. Need for Movement- The tendency to be more attracted to objects with properties of movement than stationary objects.
3. Visual Latency- A delayed response from the time a target is presented to when it is visually regarded.
4. Visual Field Preferences- The tendency to ignore information presented in non-preferred areas of one’s visual field.
5. Difficulty with Visual Complexity- Difficulty processing complexity of the surface of an object, the background/viewing array, the sensory environment, and/or of faces.
6. Light Gazing, Non-Purposeful Gaze- The tendency to spend prolonged periods of time gazing at lights, out windows, or at lighted objects.
7. Difficulty with Distance Viewing- Tendency to position visual targets close to one’s face, and/or have difficulty recognizing targets beyond near space. Presents similarly to nearsightedness.
8. Atypical Visual Reflexes- Presence of atypical reflex responses, including blink to touch and blink to visual threat.
9. Difficulty with Visual Novelty- Typical visual responses are alert to targets that are new, unusual, or unfamiliar. Individuals with CVI often have an “anti-novel” response, and familiar targets are regarded, while new ones are ignored.
10. Visual Motor- Difficulty coordinating simultaneous visual gaze and physical reach (Roman-Lantzy, 2007).

Environmental Barriers and Adaptations

For the patient with CVI, environmental factors can greatly impact use of functional vision. Vision drives much of what we do and how we move, so it is important we consider how it will impact posture and mobility when evaluating for adaptive equipment. One significant environmental barrier for a patient with CVI is complexity. Complex items, backgrounds, and environments can be overstimulating and difficult to process. As a result, we may see behaviors such as increased light gazing or a head down posture when individuals “shut down” to visual input. How often do we see a patient who consistently stares at the ceiling with a hyperextended neck, or someone with their head down and assume it is due to poor head control? Decreased head control could certainly be part of the equation, but these head postures could in part be the result of difficulty processing visual complexity. We must not only consider appropriate support and alignment

of the head and neck but also why the patient is assuming this posture. The patient with CVI may try to escape more restrictive head support, whereas decreasing complexity of the environment or activities may lead to intermittently demonstrating better head posture in more dynamic positioning.

Other environmental considerations include distractions from lights, bright colors, reflective surfaces, or movement in the environment. Individuals with CVI may demonstrate increased light gazing within novel environments or activities. Just as environmental complexity can impact head posture, these too may impact head posture and resulting postural accommodations. Moving the placement of a visually compelling item, or turning the patient's positioning equipment, are also simple interventions that could have just as profound an effect on posture as providing supports to block an atypical pattern.

Finally, we should consider that for the patient with CVI, objects with less preferred qualities (dull colors, static items) may be more difficult to visually attend to. This could impact posture because the patient must have something visually appealing to look at, in order to sustain an upright head posture, or look/move to a target. The patient with CVI may require visual targets that are brightly colored, lighted, or having other preferred visual characteristics. If movement is a visual preference, the patient may even seek out visual movement by trying to move his or her head, body, or hands in front of face. These considerations can all have significant impact on posture. While real-world situations often do not allow us to control the environment or incorporate visual preferences all of the time, they can certainly be a part of our plan to address positioning within adaptive equipment, in combination with the right amount of postural supports.

Positioning Barriers and Adaptations

One of the most significant barriers within a positioning system for a patient with CVI is that traditionally, individuals are expected to hold their head up at midline to "visually attend". However, it is common for individuals with CVI to have preferred visual fields, or to alternate use of fields, which makes midline viewing difficult (Roman-Lantzy, 2007). As a result, we often see asymmetrical head postures to accommodate for visual needs. This can lead to difficulty tolerating positioning supports. It is important for patients to be well supported for alignment and stability, however positioning systems should provide sufficient flexibility to allow individuals to assume postures for best use of their functional vision. Too many postural supports or restrictive headrests can interfere with the patient's ability to use their preferred visual field during daily tasks. So how can we achieve both good alignment and good visual setup? Knowing preferred visual behaviors and reasons for a patient's head posture, in addition to his or her physical control and alignment, can help us setup a more dynamic system. For example, a swing away spot pad or a neck collar could be used intermittently throughout the day at times of rest or fatigue, then removed to allow for head postures necessary for a patient to use his or her best functional vision during a specific task.

Use of tilt, and types of tray surfaces provided with positioning equipment are also factors impacting the patient with CVI. Frequent use of tilt may contribute to increased light gazing, and should be used judiciously for the patient with CVI. More tilt may be used during periods of rest or activities with few visual expectations, but the patient should be positioned upright to increase use of vision during functional tasks and socialization. Use of prone standers, for patients who can tolerate them, can also naturally decrease light gazing due to the decreased ability to be in a tilted position. With regard to trays, a clear surface may show clutter under/ in the background, making it difficult for a patient to use as a working surface. Opaque trays help eliminate this problem, and provide a solid, simple working surface. If opaque trays are not available, consider covering a tray with dark contact paper. Additionally, positioning of items flat on tray is not ideal for many individuals with CVI, thus angle adjustable trays, slant boards on a tray, or additional mounts may be necessary.

Finally access to a patient's wheels, drive controls, or wheel locks may also be more challenging for the individual with CVI due to preferred head position, visual field preferences, and a decreased ability to look and touch at the same time. We should consider whether needed controls are within a user's preferred fields, and whether additional visual adaptations such as color could be applied to draw visual attention. If a patient struggles with visually guided reach due to CVI, alternative access methods for drive controls or augmentative communication may be necessary. We should be cautious of equipment features that could distract visual attention away from an activity or a target in the distance for some patients with CVI (i.e. bright colored equipment, light up wheels).

Mobility Barriers and Adaptations

Vision and mobility are inherently linked, thus functional visual deficits from CVI can be significant when it comes to mobility. Individuals with CVI may have difficulty attending to, experiencing, or learning from things outside of their visual range. Additionally, decreased visual attention at distance often leads to less drive to initiate visually guided mobility and exploration. It can also result in increased difficulty finding things at distance or navigating a complex or novel environment. For example, an individual with CVI may be able to drive a power wheelchair well in a familiar home environment, but require assistance in novel or crowded places in the community. Someone with CVI may require additional time to become familiar with the surroundings and the wheelchair setup, before becoming independent with mobility.

Other notable factors impacting visually guided mobility include decreased eye contact, latency, and fleeting attention. These behaviors can give the appearance of being disengaged or unable to understand activity demands. It may lead to misinterpretation of the patient's attention or ability locate a visual target, and follow directions. These misconceptions often result in increased verbal cuing, which can be distracting. Rather than verbal cuing, it is more effective to use simple, brightly colored materials as a target to help draw and sustain the attention needed to guide mobility. Strategic placement of visual targets within a patient's distance viewing abilities, is also important to aid in navigation.

Conclusion

Functional vision plays a vital role in successful setup and use of adaptive equipment. Visual assessment is key in the equipment evaluation, particularly for patients with neurological impairment and complex physical needs. Given the high incidence of cortical visual impairment (CVI) and visual processing delays among this population, recognizing and understanding CVI can dramatically alter equipment setup. It is crucial evaluators identify appropriate supports and setups to improve tolerance and function within a positioning system.

References

1. Fazzi, E et al. (2012) Neuro-ophthalmological disorders in cerebral palsy: ophthalmological, oculomotor, and visual aspects. *Developmental Medicine & Child Neurology* 2012, 54: 730-736
2. Good, W. V., Jan, J. E., Burden, S. K., Skoczenski, A., & Candy, R. (2001). Recent advances in cortical visual impairment. *Developmental Medicine and Child Neurology*, 43: 56-60.
3. Kong, L., Fry, M., Al-Samarraie, M., Gilbert, C., & Steinkuller, P. G. (2012). An update on progress and the changing epidemiology of causes of childhood blindness worldwide. *Journal of American Association for Pediatric Ophthalmology and Strabismus*, 16(6), 501-507.
4. Roman-Lantzy, C. (2010). *Cortical visual impairment: An approach to assessment and intervention*. NY, NY: AFB Press.
5. Tallent, A., Tallent, A., & Bush, F. (2012). *Little bear sees: How children with cortical visual impairment can learn to see*. Little Bear Sees Publishing. www.littlebearsees.org

Contacts:

Katherine (katherine.eingle@cchmc.org)
Erin (erin.pope@cchmc.org)

IC46: Assessing Mobility for Those with Cortical Visual Impairment (Intermediate)

Cindi Petito, OTR/L, ATP, CAPS
Angie Kiger, MEd, CTRS, ATP/SMS

Abstract:

Cortical visual impairment (CVI) is a visual impairment resulting from various types of brain injury. Children and adults who have CVI have visual function deficits, but have normal eye exams with no apparent abnormalities in the structure of the eye or optic nerve. Therefore, the visual deficits seen with CVI are the result of interference in the visual processing centers and visual pathways of the brain. CVI is the most common cause of visual impairment in children in the U.S. Evaluating and recommending a proper mobility device and seating system for a child with CVI can be complex depending on the diagnosis related to their physical and neurological impairments. CVI impacts postural patterns and head positions since the child will often move in their seating system simply to gain their visual field or preferred area of vision. This session will discuss how to assess manual and power mobility needs for those with CVI.

Learning Objectives:

- Participants will express an understanding of the ranges of cortical visual impairments.
- Participants will be able to list at least 3 considerations to take into account when conducting a seating and mobility evaluation on an individual with a visual impairment.
- Participants will be able to list 3 adaptations that can be made to a wheeled mobility device to increase successful utilization for clients with visual impairments.

Introduction:

Approximately 40-50% of the brain is involved in vision and 20-40% of individuals who have sustained a brain injury have some degree of visual impairments. Vision plays a key role in seating, positioning, and independent mobility. In fact, a child's motor development can be significantly impacted in a negative way if there is the presence of a visual impairment, because vision provides vital feedback to the vestibular and proprioceptive systems (Prechtl et al. 2001).

Cortical Visual Impairment (CVI), also referred to as cerebral visual impairment, is defined as blindness or a visual impairment secondary to damage or malfunction of visual pathways or visual centers in the brain (Chokron & Dutton 2016). A CVI can occur both congenitally or be acquired. CVI is the largest and fastest growing visual impairment diagnosis among children in first world countries. The majority of individuals with CVI have comorbidities including cerebral palsy, epilepsy, cerebral hemorrhage, microcephaly, and cognitive disabilities (Roman-Lantzy 2007).

A proper seating system for a client with CVI can be complex depending on the diagnosis related to their physical and neurological impairments. CVI impacts postural patterns and head positions since the child will often move in their seating system simply to gain their visual field or preferred area of vision. For those individuals working in the world of complex rehabilitation technology with clients who have congenital and/or acquired CVI, it is essential to have a basic understanding of the diagnosis and how CVI may impact a client.

The primary objectives of this discussion are to provide an overview of CVI and strategies needed to conduct successful seating and mobility evaluations for clients with CVI.

Process:

When it comes to recommending any type of assistive technology (AT) including a seating system and wheelchair for a client of any age, it is essential that a thorough evaluation be completed. In general, an AT evaluation should include the following: a review of the client's medical history, an interview with client and caregiver, assessment of the client's current abilities, a seating and positioning assessment, equipment trial, recommendation of equipment, completion of documentation and the funding process, equipment delivery, training of the prescribed equipment, and follow-up (Cook & Polgar 2008).

Vision is a tremendous factor in the overall development of an individual's development and mobility skills; however, the degree in which vision status is taken into consideration during a wheelchair evaluation may vary based on medical history provided, caregiver input, type of equipment the client is being evaluated for (dependent versus independent mobility system), time allotted for the evaluation, understanding of visual deficits by the evaluators, etc.

Unfortunately, deficits such as CVI can be considered an invisible diagnosis. As mentioned previously a client with CVI often has other disabilities and/or medical conditions, some of which are physically more noticeable such as cerebral palsy. Caregivers and treatment teams may focus primarily on the conditions that are more readily noticed thus inadvertently overlooking the presence and/or impact of CVI on the client as related to seating and mobility (Chokron & Dutton 2016). The even more difficult part of working with an adult or child who has CVI is that in most cases the individual's standard vision test results are normal (Roman-Lantzy 2007), which could have a negative impact on the results of the wheelchair evaluation. For example, if the client has not been diagnosed with CVI prior to the evaluation, the medical reports state that his vision is normal, and family members state they believe the client sees based on specific circumstances, the evaluating team may not realize the need to incorporate specific strategies and adaptations to address the client's CVI.

While it is not appropriate to assume a diagnosis of CVI will be made during a wheelchair evaluation, it is important that the team members understand the common characteristics exhibited by individual's with CVI and techniques for optimizing seating and mobility equipment to enhance the

client's success in the wheelchair. In addition, if a client presents with characteristics of CVI, but has not been diagnosed, it may be helpful to recommend that the family and medical team look into the possibility of having the client evaluated for CVI so that proper treatment for the deficit can be initiated. A common myth related to CVI is that the individual's vision will never improve (Tallent, Tallent, & Bush 2012).

Dr. Christine Roman-Lantzy is credited with developing one of the most highly utilized assessment and intervention resources for working with clients who have CVI. Through her research Roman-Lantzy identified the following as common characteristics exhibited by individuals with CVI: strong color preferences; need for movement (only see when moving themselves or the object is moving); visual latency (delayed responses to visual stimuli); visual field preferences; difficulty with visual complexity; light gazing and nonpurposeful gaze; difficulty with distance viewing; absent or atypical visual reflex responses; difficulty with visual novelty; absence of visually guided reach; and coexisting ocular conditions (Roman-Lantzy 2007). Dr. Roman-Lantzy developed The CVI Range which is a protocol related directly to the characteristics to assist with assessing skills, tracking progress, and developing treatment plans for the client with CVI.

Conclusion:

By understanding the characteristics of CVI and strategies for working with clients who have CVI, it is more likely that professionals will be able to better seat their clients with CVI for a greater level of success and independence with mobility.

References:

1. Bush, F., Tallent, A., & Tallent, A. Little Bear Sees: How Children with Cortical Visual Impairment Can Learn to See. Burlingame, CA. Little Bear Sees Publishing. 2012
2. Chokron, S., & Dutton, G. N. (2016). Impact of Cerebral Visual Impairments on Motor Skills: Implications for Developmental Coordination Disorders. *Frontiers in Psychology*, 7.
3. Cook, A., Polgar, J. Cook and Hussey's Assistive Technologies: Principles and Practice 3e. Philadelphia: Mosby (2008)
4. Prechtel, H. F., Cioni, G., Einspieler, C., Bos, A. F., & Ferrari, F. (2001). Role of vision on early motor development: Lessons from the blind. *Dev Med Child Neurol Developmental Medicine and Child Neurology*, 43(03), 198.
5. Roman-Lantzy, C. (2007). *Cortical visual impairment: An approach to assessment and intervention*. New York, NY: AFB Press.

Disclosure

I, Cindi Petito, have not had an affiliation with an equipment, medical device or communications organization during the past two calendar years. I am employed by the National Rehabilitation Hospital as an occupational therapist in the Seating and Mobility Clinic. I do not intend to promote or endorse any particular brand or product as a part of this clinical presentation.

I, Angie Kiger, have/had an affiliation with an equipment, medical device or communications organization during the past two calendar years. I am employed full time by Sunrise Medical US, LLC as clinical educator. I do not intend to promote or endorse any particular brand or product as a part of this clinical presentation.

IC47: Solving Complex Seating Clinic Challenges in an Intense Climate

Meredith J. Budai, DPT, ATP/SMS

Beth Farrell, PT

Erin Michael, PT

Sarah Murdoch, PT

Colleen Smith, PT

Session Description: The seating climate is more intense. Patients continue to come to clinic with complex needs, requiring creative mobility solutions used within the bounds of strict reimbursement rules and good seating practice. This session reviews challenging patient cases, detailing the problems seating clinics face and the identified solutions. For example, one scenario describes a patient who presented to clinic with a new wheelchair described as an “impulse buy,” funded by her insurance. She no longer likes this wheelchair and is limited as her provider does not service this product. Another patient with paraplegia used a manual wheelchair since onset of injury. Over time she developed upper extremity injury requiring use of a power wheelchair. One other patient is ambulatory in her household but requires use of a wheelchair in the community to prevent from sustaining a serious injury. Additional case examples highlight what happens when a patient’s current seating system no longer meets their needs, but replacement or modification is limited by their insurance benefit. We will provide practical solutions and insight from our experiences to best meet patients’ seating needs including insurance reimbursement and documentation requirements, reliable outcome measures to justify recommendations (including outside of the home), and the necessary patient/caregiver education which is required to successfully aide patients with unique seating situations in an intense climate.

Outcome Learning Objectives:

Upon completion of this session, attendees will be able to:

1. Describe two advantages of utilizing a functional mobility evaluation when prescribing and justifying a wheelchair.
2. Identify three outcome measures to assess fall risk in ambulatory patients and two outcome measures utilized to justify need for power assistance for use when pursuing wheeled mobility.
3. List three ways in which local coverage determination impacts eligibility for complex rehabilitation technology.
4. Compare the individual roles of the seating team including the therapist, patient, and durable medical equipment provider, and describe 3 differences between each.

References:

1. Arledge, S., ATP, Armstrong, W., MS, RET, ATP, Babinec, M., OTR/L, ABDA, ATP, Dicianno, B. E., MD, DiGiovine, C., PhD, ATP, RET, Dyson-Hudson, T., MD, . . . Stogner, J., PT, ATP. (2011, January 26). RESNA Wheelchair Service Provision Guide. RESNA, 1-26.
2. Lin, Y., Boninger, M., Worobey, L., Farrokhi, S., & Koontz, A. (2014). Effects of repetitive shoulder activity on the subacromial space in manual wheelchair users. *BioMed Research International*, 2014, 1-9. doi:10.1155/2014/583951
3. Minkel, J. L. (2000). Seating and Mobility Considerations for People With Spinal Cord Injury. *Physical Therapy*, 80(7), 701-709. Accessed July 31, 2016. Retrieved from <http://ptjournal.apta.org/content/80/7/701>.
4. Smith, E. M., Sakakibara, B. M., & Miller, W. C. (2014). A review of factors influencing participation in social and community activities for wheelchair users. *Disability and Rehabilitation: Assistive Technology*, 1-14. doi:10.3109/17483107.2014.989420
5. Sawatzky, B., DiGiovine, C., Berner, T., Roesler, T., & Katte, L. (2015). The need for updated clinical practice guidelines for preservation of upper extremities in manual wheelchair users. *American Journal of Physical Medicine & Rehabilitation*, 94(4), 313-324. doi:10.1097/phm.0000000000000203

Content Outline:

Content Outline	
Content Presented	Estimated Time
Welcome, Introduction, and Course Overview	5 Minutes
Topic A: Patient Understanding of Seating Practice	15 Minutes
Topic B: Reimbursement Rules, Timelines, and Documentation Requirements	25 Minutes
Topic C: Mobility Required Outside of the Home and Associated Outcome Measures	25 Minutes
Questions and Discussion	5 Minutes

Speaker(s) Biography:

- Meredith Budai, PT, DPT, ATP/SMS** is a physical therapist at the International Center for Spinal Cord Injury at Kennedy Krieger Institute in Baltimore, MD. She received her Doctorate of Physical Therapy in 2008 from Duquesne University in Pittsburgh, PA, has been a certified assistive technology professional since 2011, and a certified seating and mobility specialist since 2015. She has presented nationally on activity based rehabilitation application in SCI seating and positioning.
- Beth Farrell, PT, DPT, ATP/SMS:** Beth Farrell, PT,DPT,ATP/SMS is a physical therapist at the International Center for Spinal Cord Injury at the Kennedy Krieger Institute in Baltimore, MD. She received her doctorate in physical therapy from the University of Maryland in 2007. She also received a graduate certificate in the Business of Medicine from the Johns Hopkins Carey Business School in 2010. She has been ATP certified since 2010 and SMS certified since 2014.
- Erin Michael, PT, DPT, ATP/SMS** is the Manager of Patient Advocacy and Special Programs at the International Center for Spinal Cord Injury at the Kennedy Krieger Institute in Baltimore, MD. She received her Doctorate of Physical Therapy from Ithaca College in 2006. She has been a certified assistive technology professional since 2011 and a certified seating and mobility specialist since 2012.
- Sarah Murdoch, PT, DPT, ATP** is a physical therapist with the International Center for Spinal Cord Injury at Kennedy Krieger Institute since November of 2012. She received her Bachelor of Biology and Health Sciences and Doctorate of Physical Therapy from Duquesne University in Pittsburgh, Pennsylvania. She has been a certified assistive technology professional since 2014.

Session Level:

Intermediate

Key Words:

Spinal cord injury, Reimbursement, In the home, Community, Insurance, Specialty evaluation, Functional mobility evaluation

Conflict of Interest Disclosure:

We have no conflict of interest to disclose.

IC48: Rehab Engineers + 3-D Printing + Electronics = Personalized AT

Ben Salatin, MS

Brian Burkhardt, MS, ATP

Introduction

Over the past 6 years, clinical rehabilitation engineers have been introduced as a new type of clinical practitioner at several US Department of Veterans Affairs (VA) hospitals. This was initially brought about via the development of Assistive Technology Centers at the 5 VA polytrauma hospitals around the US. These rehabilitation engineers use technical skills and in-depth knowledge of assistive technology (AT) to complement the diverse group of clinical specialists within the rehabilitation team. Two of the new technical skills that they have brought into the clinic are the use of 3-D printing and electronic fabrication to create custom assistive technology solutions for their clients. These technologies were originally purchased as research equipment but when the rehabilitation engineers saw client needs in the clinic that were not being fully met with current off-the-shelf technology, they turned to these fabrication methods as a way to modify off-the-shelf technology and in some cases create completely new solutions. The advent of the Maker / Do-It-Yourself (DIY) Movement has created a large market for inexpensive digital fabrication technologies such as low cost 3-D printing and simple electronic development platforms, including much improved free design software and online learning tools. This has made it much easier and cheaper for rehabilitation engineers to create custom assistive technology solutions. In the VA, the types of assistive technology that can be purchased for a Veteran is much broader than in the private US medical system. This includes custom solutions that utilize parts and services from nonmedical vendors. The rehabilitation engineers at the VA are leveraging this purchasing ability in new ways to provide more comprehensive care to Veterans.

Clinical Rehabilitation Engineering in the VA

A definition of rehabilitation engineering comes from the Rehabilitation Act of 1973, which says it is the “systematic application of engineering sciences to design, develop, adapt, test, evaluate, apply, and distribute technological solutions to problems confronted by individuals with disabilities in functional areas, such as mobility, communications, hearing, vision, and cognition, and in activities associated with employment, independent living, education, and integration into the community.” Within the VA, the rehabilitation engineers focus mostly on 7 areas of assistive technology: Powered Mobility & Seating, Augmentative and Alternative Communication (AAC) Devices, Specialized Computer Access, Electronic Cognitive Devices, Electronic Aids to Daily Living, Adaptive Sports and Adaptive Driving. They collaborate with clinicians of all types in evaluating

technology, setup & configuration, training, troubleshooting and outcome measures. They assist clinicians in bringing the technical quality of AT service provision to a new level through providing trainings to staff on all types of AT, discovering new AT on the market, adapting & modifying off-the-shelf AT and creating new AT. It is in these last two areas that the rehabilitation engineers are able to bring 3-D printing and low cost electronics to the table as new clinical tools that have not been commonly used in the VA before. When properly integrated into a multidisciplinary clinical team, the rehabilitation engineer functions as an AT system integrator helping to provide a comprehensive AT package, assuring that the various AT solutions recommended by each clinician work well together. Currently there are 2 rehabilitation engineers at the Richmond, VA hospital, 1 at the Minneapolis, MN hospital, 1 at the Albuquerque, NM hospital and soon to be 1 at the Denver, CO hospital.

3-D Printing and Assistive Technology

Known in the manufacturing industry as Additive Manufacturing but popularly called 3-D Printing, the public became aware of it in 2010 when patents expiring led to the development of low-cost consumer oriented 3-D printers. 3-D printing at its simplest is like building a layer cake. By stacking multiple 2-D layers on top of each other a 3-D physical object is created. There are several methods of 3-D printing, the simplest and most common being that of filament extrusion. Essentially, it is a very precise hot glue gun but instead of glue, a plastic filament such as ABS (what LEGOs are made from) is melted and extruded into layers. This method works very well for printing with many different types of plastic. Other 3-D printing methods are used to print with flexible plastics, multi colored plastics and metals. The examples in this paper all use the filament extrusion method with ABS plastic.

In the first example, a Veteran with quadriplegia needed to mount his large smartphone to his wheelchair in a position that allowed him to fully control the phone. He wanted to be able to change the phone orientation from vertical to horizontal depending on which app he was using. The original design of the mount product that was being used involved turning a knob to change the orientation which he could not manage. The 3-D printed add-on to the mount was designed to remove the knob and allow the phone to “click” into a vertical position with an integrated spring and be held horizontal by a physical stop.

For the second example, a Veteran with paraplegia needed to self-catheterize several times a day for urination. The occupational therapist (OT) had purchased an off-the-shelf hygiene mirror product to help the Veteran hold her legs apart and see what she was doing but she could not successfully use it. The OT attempted to make a custom version of the product from splinting plastic but it was not strong enough. Based on the commercial product, using the dimensions from the OT’s version and feedback from the Veteran, a custom device was designed and 3-D printed for her by the rehabilitation engineer. This device added a hinge for easy insertion and an angle adjustable mirror & light to aid in better visualization.

Low Cost Electronics and Assistive Technology

With the decreasing cost of computer chips and the advent of the Maker / DIY Movement companies have created simple electronic development kits with free online learning and programming software that allows tinkerers to create basic computer controlled actions such as operating motors or gathering data from sensors. With some free software, hobby servo motors, some switches, sensors and a \$30 minicomputer a rehabilitation engineer can create simple devices that fit the exact needs of a Veteran.

In the first example a device was developed to enable a Veteran's independent access to hospital bed power functions for positioning. To keep from having to open and modify the electronics of a bed remote, a US Food and Drug Administration (FDA) regulated medical device, a mechanical button pusher was designed to allow the remote to be operated via infrared (IR) signals emitted from augmentative and alternative communication (AAC) devices or smart home systems. The bed remote was mounted inside a box with a 3-D printed framework of servo motors controlled by a minicomputer. When an IR command is received from the smart home system it is converted to servo motions that depress the correct buttons and move the bed.

For the second example, a Veteran with a traumatic brain injury and a spinal cord injury with a Halo fixator had limited peripheral vision. This visual deficit complicated her driving of a power wheelchair as she could not properly judge her distance from walls and kept bumping into them. The rehabilitation engineer designed a custom obstacle warning device using a minicomputer, 2 proximity sensors and some earbuds. The device emitted separate tones when it detected obstacles on the left or right side of the wheelchair. By wearing 1 earbud, the Veteran was able to still listen normally from 1 ear and hear the obstacle warning in the other ear. The system worked well and after a few months of driving the Veteran had developed a better sense of space and no longer needed the device.

Conclusion

Realizing that very few rehabilitation clinicians have access to a full time rehabilitation engineer, here are some ways that these technologies and the associated knowledge can be accessed in your community. The Maker / DIY Movement has spawned the creation of many community workshops called makerspaces or hackerspaces. These spaces contain design and fabrication equipment along with a community of tinkerers that enjoy teaching their skills to others and helping with projects. These spaces can be standalone entities or may be contained within a local public library or school. Consider contacting a local university's engineering department for help. None of this technology and the design skills required are beyond the abilities of a rehabilitation clinician to learn. The rehabilitation engineer as the technical expert fills this design and fabrication role on the rehabilitation team better but we do not all live in a perfect world. Through their technical skills in design, 3-D printing and custom electronics the VA's rehabilitation engineers have been able to bring these new tools into clinical use and provide a level of personalized AT to Veterans that has not existed before.

References

1. Prima, M., Coburn, J., Hwang, D., Kelly, J., Khairuzzaman, A., & Ricles, L. (2015). Additively manufactured medical products – the FDA perspective. *3-D Printing in Medicine*, 2(1).
2. Salatin, B. (2015) 3-D Printed Assistive Technology Creation in the Clinic: A Case Study. Proceedings of the Rehabilitation Engineering and Assistive Technology Society of North America Conference, Denver, CO.
3. Burkhardt, B. & Oliver, M. (2016) Where the Rubber Meets the Road: Makers, DIY, And Quality Control, Proceedings of the Rehabilitation Engineering and Assistive Technology Society of North America Conference, Arlington, VA.

PS6.1: Modeling Pressure Injury Conditions Caused by Toilet Seats

Amit Gefen, PhD

Maayan Lustig

Kara Kopplin

Background

A pressure injury seriously compromises the quality of life, and can also be life-threatening, particularly in its deep tissue injury manifestation. The fundamental cause of pressure injuries is sustained deformations in weight-bearing soft tissues, especially during prolonged sitting on inadequate surfaces such as a plastic toilet seat. In nursing homes and geriatric facilities, patients often need assistance in using the restroom, and patients being left on the toilet for tens-of-minutes is also a real-world scenario, unfortunately. Nevertheless, there are no published studies regarding sustained soft tissue loads during toilet sitting, and their effects on tissue physiology and tissue biomechanics status. Hence, here, the biomechanical and microcirculatory responses of the buttock tissues to toilet sitting were investigated by coupling computer modeling and simulations with experimental measurement of tissue perfusion.

Methods

We have used finite element computational modeling, interface pressure mapping and cutaneous hemodynamic measurements to explore the potential etiology of pressure injuries occurring on the toilet. We tested two different standard plastic seat designs, either covered by a specialized toilet seat cushion or not, and have determined internal tissue loads (deformations, strains and stresses) and perfusion characteristics over time in the skin contacting the toilet seat during toilet sitting.

Findings

We found that prolonged sitting on plastic toilet seats involves a potential risk for PIs, the extent of which is affected by the anatomical features, the seat design and the sitting duration. In addition, we found that specialized toilet seat cushions are able to reduce this tissue injury risk, by lowering tissue exposures to internal strains and stresses as well as to interface pressures. We observed compensatory mechanisms in the microcirculation to prolonged toilet sitting of up to 30 minutes. Frequency analysis of laser Doppler flowmetry signals provided information regarding the distinctive rhythms which constitute the skin perfusion, vasomotion of the capillaries, and oscillation in tone of the blood vessel walls during the toilet sitting. These perfusion measurements revealed a reduction in the frequency intensity of the flow, which points to the compensatory vasomotion of the capillaries in the distorted skin tissue during the toilet sitting.

Discussion

The present work illustrates that investing in expensive pressure injury prevention products such as high-end beds or chairs is likely to be ineffective for an immobilized patient who is left to sit on a bare (plastic) toilet seat for long times. This argument points to the need for a holistic care approach, employing pressure injury prevention devices that span across the entire environment where bodyweight forces apply to tissues.

Conclusions

Using computational finite element modeling and assessment of the microcirculatory response to toilet sitting, we found that prolonged sitting on toilet seats involves a potential risk for pressure injuries – particularly deep tissue injuries. The extent of the risk to the individual is affected by the toilet seat design, as well as by the individual anatomy and tissue biomechanical properties, and the duration of tissue exposure to the weight-bearing. In addition, we found that specialized toilet seat cushions substantially reduced the tissue injury risk, by lowering tissue exposures to internal strains and stresses as well as to interface pressures. Most importantly, the present work illustrates that investing in expensive pressure injury prevention beds or cushions is likely to be ineffective for an immobilized patient who is left to sit on the toilet for long times. This argument points to the need for a holistic care approach – including a range of medical devices for pressure injury prevention – throughout the entire environment where bodyweight forces apply, in order to minimize the occurrence of these wounds.

PS6.2: An MRI Investigation Evaluating Tissue Response to Seat Cushions

David M Brienza, PhD

Jaxon Vallely, B.Phil

Patricia Karg, MSE

Jonathan Akins, PhD

Kara Kopplin

Amit Gefen, PhD

Introduction

Tissue deformation contributes to the development of pressure injuries by restricting blood flow and disrupting cell membrane transport mechanisms [1-5]. In practice, quantifying deformation is difficult. Although, a method for using ultrasound has been recently investigated[6], current best practice for evaluating the pressure injury risk imposed by sitting or lying on a mattress or cushion is the use of interface pressure mapping systems. However, pressure mapping is not an ideal tool for evaluating pressure injury risk introduced by loading for several reasons: the reliability of the measurements have been questioned[7]; the measurements are only an indirect indication of the internal stress and strain that create the potential for damage; and finally, clinical research has failed to establish pressure magnitude-based guidance on levels of interface pressure that correspond to higher or lower pressure injury risk [8].

The efficacy of cushions intended to provide skin and soft tissue protection in preventing pressure injury has been demonstrated [9-11]. But choosing between the many varieties of tissue protection cushions to best meet a specific patient's needs remains a challenge and anecdotal evidence from practitioners indicates that certain types of cushions provide better or worst protection from injury for individuals. Tissue protection cushions have been shown to decrease sitting pressure, decrease sitting asymmetry[12], decrease internal tissue strains[13, 14], and most importantly, lower sitting acquired pressure injury incidence[9, 11]. Studies focused on comparisons between tissue protection cushions and foam cushions are most common in the literature.

While interface pressure mapping systems can successfully measure superficial skin loading, most pressure injuries that develop superficially are the result of moisture or friction. Most pressure induced injuries show evidence of deep tissue injury, and it has been questioned if in fact all pressure injuries develop internally before presenting on the superficial layers[15]. Cushions are designed to relieve pressure, so the deeper tissues should be considered when evaluating and selecting a cushion.

This investigation is a three-dimensional analysis-based comparison of tissue response around the ischial tuberosities for people with and without spinal cord injuries. The response was measured for participants seated on a variety of wheelchair cushions. It is intended to be a first step in a process to develop a better risk assessment tool based upon anatomy.

Methods

Six participants were recruited for this observational cross-sectional study. Four of the individuals had sustained a spinal cord injury (SCI) and used a wheelchair full time due to partial or complete loss of lower extremity function. Two participants were without SCI, two people had been injured less than a year before participation, and two people who had been injured more than ten years before participating.

Magnetic resonance (MR) imaging examinations were conducted using a 0.6 Tesla Upright MRI (FONAR Corporation, Melville, NY, USA). A seven-image series was taken for each participant, centered on the ischial area of the pelvis: one with the buttock tissue unloaded, and six in the seated posture on six different wheelchair cushions. T1 weighted images were collected in the coronal plane with a 256 × 256 matrix, 30 cm × 30 cm field of view, slice thickness of 3.0 mm and inter-slice distance of 0.2 mm. The duration of each sequence was approximately 14 min. The same licensed radiological technologist performed the scans for all participants. A planar coil, typically used to acquire thoracic–lumbar images, was placed on the FONAR seat cushion (non-rigid) and a wood seat insert (457 mm × 406 mm, 18 in × 16 in) was placed over the coil and FONAR seat cushion. Additional foam padding was used to stabilize the wood insert.

To obtain the unloaded image, an MR compatible wheelchair seat cushion, the ROHO® Quadro Select® High Profile® Cushion (457 mm × 406 mm, 18 in × 16 in) was placed on top of the wood insert and the same setup was used for all participants. MR images were collected with the participants positioned to represent a seated posture by placing them in a supine position with hips and legs flexed to mimic the seated posture. The six cushions were of various constructs and included: molded foam base with fluid layer, interconnected air cells, contoured honeycomb, contoured foam base with fluid pelvic insert, independent air cells within compartments, and foam-air combination. Each participant laid supine for the unloaded MRI, with both hips and knees flexed to 90° and supported in this position. All loaded MRIs were taken with the participants sitting in an upright position with both hips and knees flexed to 90°. Pillows and padding were used as necessary to maintain postural stability.

Three-dimensional models were created using Analyze 12.0 (AnalyzeDirect, Overland Park, KS). DICOM images were imported into the software, and a combination of semi-automatic and manual segmentation was carried out by one individual to separate the pelvic bone, fat, gluteus maximus, semitendinosus, and semimembranosus. A radiologist was consulted in areas where tissue identifications were difficult to interpret. The 3D models were cropped based on the ischial tuberosity (IT) shape so that only the tissue directly under the IT was maintained in the image, and defined as the Region

of Interest (ROI). The ROI was defined by reducing the model as follows. All frames where the IT border was less than 6mm superior to the true IT peak (lowest point of the ischium) were selected (anterior-posterior). From that range the medial and lateral borders of the IT peaks were selected, and the image was sliced along these borders (medial-lateral).

Soft tissue volumes in the ROI below each IT were found using the Analyze 12.0 software for total soft tissue and for each tissue type separately (fat, gluteus maximus muscle, semitendinosus muscle, and semimembranosus muscle). Tissue response when seated on a cushion was quantified under each IT as one minus the ratio of the total tissue volume in the ROI while seated on the cushion to the volume in the ROI in the unloaded condition (equation 1). The degree of asymmetry on each cushion was calculated as per equation 2, where R_{left} and R_{right} were the tissue response (R) from equation 1 for the left and right IT, respectively. The composition of the tissue in the ROI below each IT on each cushion was also explored.

$$Response = R = \left(1 - \frac{Tissue\ Volume_{Unloaded}}{Tissue\ Volume_{Loaded}}\right) \times 100\% \quad (\text{Equation 1})$$

$$Asymmetry = |R_{Left} - R_{Right}| \quad (\text{Equation 2})$$

Results

Participant demographics are presented in Table 1. In the unloaded condition, Control 1 had a large amount of muscle, while Control 2 and Short Term SCI 1 had a moderate amount of muscle. Short Term SCI 2 and both Long Term SCI participants had a very low amount of muscle, and that muscle was primarily hamstrings, not gluteus maximus muscle like the first three participants.

Table 1: Participant Demographics

Participant	Age (years)	Injury Level	Time since SCI (Years)	Weight (kg)
Control 1	22	-	-	73.5
Control 2	26	-	-	49.9
Short Term SCI 1	34	T10	0.7	68.0
Short Term SCI 2	31	T3	0.5	77.1
Long Term SCI 1	41	T12	23.6	64.0
Long Term SCI 2	41	C6	13.7	86.2

Table 2 shows the response of the total volume of soft tissue in the ROI to loading on each cushion. Table 3 shows the response of the fat tissue in the ROI to loading on each cushion. Table 4 shows the response of the muscle tissue in the ROI to loading on each cushion. In Tables 2, 3 and 4 the change in volume for the side of the pelvis with the most change is shown. The percentage is coded with a color where green represents the best result (the least volume change) for a particular participant among the six different cushions. Table 5 shows the measure of total tissue volume asymmetry on each cushion as defined in the methods section.

Table 2 - Total volume change in the ROI for each participant for each cushion relative to the unloaded volume. The relative changes are coded by a continuous color scale where green represents the least change in volume and red represents the most change in volume for each individual participant across all six cushions.

Participants	Cushions					
	A	B	C	D	E	F
Control 1	38%	59%	55%	60%	48%	46%
Control 2	30%	20%	23%	47%	24%	29%
Short Term SCI 1	44%	55%	62%	69%	68%	62%
Short Term SCI 2	65%	54%	53%	52%	63%	46%
Long Term SCI 1	59%	57%	61%	68%	64%	66%
Long Term SCI 2	52%	41%	58%	59%	54%	51%

Table 3 - Fat tissue volume change in ROI for each participant for each cushion relative to the fat volume in the unloaded condition. The relative changes are coded by a continuous color scale where green represents the least change in volume and red represents the most change in volume for each individual participant across all six cushions.

Participants	Cushions					
	A	B	C	D	E	F
Control 1	34%	28%	12%	31%	28%	30%
Control 2	34%	16%	28%	40%	31%	32%
Short Term SCI 1	20%	30%	40%	50%	50%	39%
Short Term SCI 2	61%	48%	49%	47%	58%	42%
Long Term SCI 1	55%	55%	58%	65%	62%	64%
Long Term SCI 2	51%	39%	56%	57%	52%	49%

Table 4 - Muscle tissue volume change in ROI for each participant for each cushion relative to the muscle volume in the unloaded condition. The relative changes are coded by a continuous color scale where green represents the least change in volume and red represents the most change in volume for each individual participant across all six cushions.

Participants	Cushions					
	A	B	C	D	E	F
Control 1	59%	83%	84%	76%	76%	69%
Control 2	69%	39%	19%	82%	40%	12%
Short Term SCI 1	88%	100%	100%	100%	100%	100%
Short Term SCI 2	95%	94%	91%	92%	96%	81%
Long Term SCI 1	98%	75%	89%	100%	98%	96%
Long Term SCI 2	89%	84%	93%	86%	85%	86%

Table 5 - Asymmetry of total tissue volume change response. The relative changes are coded by a continuous color scale where green represents the smallest asymmetry and red represents largest asymmetry for each individual participant across all six cushions .

Participants	Cushions					
	A	B	C	D	E	F
Control 1	6%	17%	19%	13%	12%	16%
Control 2	1%	9%	21%	6%	1%	8%
Short Term SCI 1	18%	2%	16%	24%	23%	17%
Short Term SCI 2	5%	12%	3%	7%	7%	1%
Long Term SCI 1	26%	22%	21%	18%	28%	19%
Long Term SCI 2	0%	4%	3%	1%	3%	2%

Discussion and Conclusions

No one cushion preserved tissue volume under the ischial tuberosities best for all subjects. And, no one cushion prevented asymmetry of change in tissue volume best for all subjects. Tissue response varied measurably for individual subjects by cushion. Consistent with the observations of prior studies[16, 17], subjects with SCI had little or no muscle under their IT when they were sitting. Finally, atrophy was evident in both the subjects with recent (≤ 0.7 years) spinal cord injuries and those with injuries from 14 and 24 years ago.

References

1. Bouten, C.V., et al., Compressive deformation and damage of muscle cell subpopulations in a model system. *Annals of biomedical engineering*, 2001. 29(2): p. 153-163.
2. Breuls, R., et al., Compression induced cell damage in engineered muscle tissue: an in vitro model to study pressure ulcer aetiology. *Annals of biomedical engineering*, 2003. 31(11): p. 1357-1364.
3. Breuls, R.G., et al., A theoretical analysis of damage evolution in skeletal muscle tissue with reference to pressure ulcer development. *Journal of biomechanical engineering*, 2003. 125(6): p. 902-909.
4. Linder-Ganz, E., et al., Pressure-time cell death threshold for albino rat skeletal muscles as related to pressure sore biomechanics. *Journal of biomechanics*, 2006. 39(14): p. 2725-2732.
5. Salcido, R., et al., Histopathology of pressure ulcers as a result of sequential computer-controlled pressure sessions in a fuzzy rat model. *Advances in Skin & Wound Care*, 1994. 7(5): p. 23-42.
6. Akins, J.S., et al., Feasibility of freehand ultrasound to measure anatomical features associated with deep tissue injury risk. *Medical Engineering & Physics*, 2016. 38(9): p. 839-844.
7. Sprigle, S., W. Dunlop, and L. Press, Reliability of bench tests of interface pressure. *Assistive Technology*, 2003. 15(1): p. 49-57.
8. Reenalda, J., et al., Clinical use of interface pressure to predict pressure ulcer development: a systematic review. *Assistive Technology*, 2009. 21(2): p. 76-85.
9. Geyer, M.J., et al., A randomized control trial to evaluate pressure-reducing seat cushions for elderly wheelchair users. *Advances in skin & wound care*, 2001. 14(3): p. 120-129.
10. Brienza, D.M., et al., The relationship between pressure ulcer incidence and buttock-seat cushion interface pressure in at-risk elderly wheelchair users. *Archives of physical medicine and rehabilitation*, 2001. 82(4): p. 529-533.
11. Brienza, D., et al., A randomized clinical trial on preventing pressure ulcers with wheelchair seat cushions. *Journal of the American Geriatrics Society*, 2010. 58(12): p. 2308-2314.
12. Kim, W.-J. and M. Chang, A Comparison of the Average Sitting Pressures and Symmetry Indexes between Air-adjustable and Foam Cushions. *Journal of physical therapy science*, 2013. 25(9): p. 1185.
13. Levy, A., K. Kopplin, and A. Gefen, An air-cell-based cushion for pressure ulcer protection remarkably reduces tissue stresses in the seated buttocks with respect to foams: Finite element studies. *Journal of tissue viability*, 2014. 23(1): p. 13-23.
14. Shoham, N., et al., Contoured Foam Cushions Cannot Provide Long-term Protection Against Pressure-Ulcers for Individuals with a Spinal Cord Injury: Modeling Studies. *Advances in skin & wound care*, 2015. 28(7): p. 303-316.
15. Berlowitz, D.R. and D.M. Brienza, Are all pressure ulcers the result of deep tissue injury? A review of the literature. *Ostomy/wound management*, 2007. 53(10): p. 34-38.
16. Sonenblum, S.E., et al., 3-dimensional buttocks response to sitting: a case report. *Journal of tissue viability*, 2013. 22(1): p. 12-18.
17. Sonenblum, S.E., et al., 3D anatomy and deformation of the seated buttocks. *Journal of tissue viability*, 2015. 24(2): p. 51-61.

PS6.3: How a Cushion Can Effectively Protect Against Pressure Injury

Amit Gefena, PhD

Ayelet Levya, MSc

Naama Shohama, MSc

Kara Kopplinb, BSc

Background

In this talk, we will demonstrate the novel use of biomechanical computational modeling in assessment of cushions aimed at minimizing the risk for pressure injuries. We will further discuss the ability of computational modeling to isolate different risk factors associated with either the cushion or the individual. Important developments have occurred in the field of pressure injury prevention in the last decade. First, the etiology of pressure injuries is now better understood. Second, the pathoanatomical variations in individuals, both between persons and over time in the same person can be determined and considered. Third, the aforementioned computer simulation tools are available and are cost-effective. Taken together, these developments facilitate the identification of several key characteristics of effective wheelchair cushion designs, as explained below.

Methods

The finite element method is a computational technique for finding the internal mechanical loads (e.g. deformations, strains and stresses) in structures having complex shapes and multiple material components. In practice, the geometry of structures that are as complex as the human body is divided into numerous small elements – each with a much simpler geometry (such as small bricks or pyramids), and the governing equations that describe the mechanical interactions (between and within tissue types) are solved numerically for every element with respect to its neighboring elements, in order to ultimately construct the solution of internal load distributions to the entire organ or tissue-complex structure. The geometry of the organ or tissue structures is imported to the modeling from magnetic resonance imaging (MRI) scans, which, in the context of sitting studies, are conducted in an open (seated) MRI configuration. Hence, the combination of MRI and computational finite element modeling provides a realistic insight into how the body, its organs, tissues and cells are deforming and overall responding biomechanically to weight-bearing loads.

Results

Using MRI coupled with finite element computer modeling, as detailed above, sufficient immersion and envelopment of the body were identified as key factors in the design of a good

cushion. Together, immersion and envelopment represent the potential cushioning performance through minimization of internal tissue deformations, strains and stresses, particularly near the bony prominences of the ischial tuberosities.

Adjustability of the cushion is another key factor to achieving this end, as body types vary considerably among people, and can change substantially over time, especially given the remarkable disuse-related anatomical and physiological changes during months and years of chronic sitting, e.g. in elderly, in people with neuromuscular injuries or diseases, and post trauma to the central nervous system. Adaptability is an additional key factor, as the cushion has to be able to accommodate changes in posture and weight shifts associated with daily living throughout the entire period of intended use. Furthermore, with regard to durability, the cushion should maintain its physical and mechanical properties as well as its performance over several years, despite exposure to degenerating conditions e.g. temperature changes, wear against materials and exposure to body fluids.

Discussion

Science and public policy are in a virtual “tug-o-war” regarding beneficiary access to the goods and services that address their needs. When credible science exists to point to advantageous technologies or medical device designs, then policy makers are compelled to take notice and will find it difficult to ignore in establishing coverage and reimbursement policies. However, when scientific knowledge is insufficient in a specific field, and this may still be the case in pressure injury prevention and treatment research, policymakers are prone to establishing coverage and payment rules that primarily focus on financial objectives (of minimizing expenditure), or are biased towards broad characterization and commoditizing of medical equipment, with less attention to ensuring that products are indeed capable of meeting the medical needs of the individual users. The problems that this creates are exacerbated by the fact that health care policies, coverage and reimbursement are often being compartmentalized by care settings with no consideration of the care and treatment of individuals throughout the continuum of care (e.g. across departments in the same institute, between different facilities, from acute to chronic care or from acute to community care). Over time, this may actually increase the overall costs to the individual and the healthcare system, as the needs of the individual are eventually unmet or partially met, and further damage occurs. For example, if certain wheelchair cushions that are prescribed and reimbursed for prevention or care of pressure injuries do not actually provide the intended benefits to the individual (though policy makers assumed they would, due to a gap in understanding), the prevalence and incidence of pressure injuries in the wheelchair user population will actually rise. Over time, this will push the healthcare costs upwards, with regard to both the cost components imposed on the individuals and those paid by the healthcare system, insurance or government.

Conclusions

There are important advancements recently in understanding the etiology of pressure injuries and in the availability of novel research tools and methodologies to assess cushion efficacies, particularly concerning imaging modalities combined with computational biomechanical modeling. Nevertheless, there are still considerable gaps between public policy and current practice in cushion evaluation, and the challenges and measures that should be applied. Here we listed the key factors that should be considered in any cushion product selection or design process: immersion/envelopment, adjustability, adaptability, and durability.

PS6.4: Factors affecting seating prescription: an evaluation of Watercell® technology in complex static chairs

Carol Bartley, MS

Melanie Stephens, MA, RN

Abstract

This paper will highlight important factors practitioners should consider when prescribing seating for people who sit for extended periods of time (comfort, pressure redistribution, aesthetics, function, posture, occupation, support and end user collaboration). These factors are based upon a mixed methods study that evaluated the pressure redistributing effects of WaterCell® technology in specialist seating. Average and peak pressures were then compared to self-reported discomfort scores, physiological observations, and semi structured interviews of twelve participants (five male, seven female).

Background

The assessment and prescription of seating for people with health and mobility needs is a multi-faceted process (Schein et al 2010). Studies suggest that, when managed correctly the client gains include postural support and the ability to participate in occupations which can impact on health and wellbeing (Rosseau-Harrison et al. 2009, Gagnon et al 2005). Limitations of these studies are that the focus is on wheelchair users and their function and posture without considering other factors such as pressure management. The financial burden on worldwide healthcare systems (Guest et al 2015) in the treatment of pressure ulcers indicates that a more sustainable and consistent approach is required; to alleviate liability and reduce the physiological and psychological impact on all clients who remain seated for long periods (Langemo et al. 2000). A search of the literature revealed a dearth of evidence regarding assessment and provision of static seat chairs, with much relating to wheelchair seating and pressure cushions (Kim and Chang 2013, Gil-Aguido et al. 2009, Crane 2004). However, Collins (1999) comparative study evaluated the impact of a static seat with a pressure relieving cushion, and an ordinary chair on pressure ulcer occurrence in ward based patients. Only one person developed a pressure ulcer in the experimental group compared to nineteen in the control group. Collins (1999) stated that seating was equally as important as other equipment in the prevention and management of pressure ulcers. When seated, the majority of the body weight is borne over the area around the ischial tuberosities and gluteal region which increases the risk of pressure ulcer development (Barbenel 1991, Defloor and Grypdonck 1999). Despite this, little attention has been paid to the impact of static specialist chairs. Typically, an assessment for a seating

device is usually carried out by an occupational therapist who considers contextual factors such as environment, user preferences, and personal requirements such as portability (Moody et al. 2015). Indeed, user preferences relating to comfort/discomfort, pain, and function have been reported previously with non-concordance when the end user is not an active participant in the process (Crane & Hobson 2002). Stockton & Rithalia (2009), in their clinical seating guidelines recommend a collaborative approach to seating assessment with consideration of user and carer opinions in seat selection, but do not address this in specific detail. Other factors to consider in the assessment and prescription of static seating from Collins (2007) three case studies, include diagnosis, risk assessment, skin inspection, client's environment, and transfer abilities. Therefore, the importance of appropriate assessment and prescription of seating should not be underestimated as inappropriate provision can effect health, function, and quality of life in the form of pain, discomfort and skin integrity changes (Giesbrecht, Mortenson, and Miller 2012).

Methods

The objectives were to evaluate the impact of WaterCell® Technology in three CareFlex chairs (HydroTilt, SmartSeat and SmartSeat Pro) and the effect on pressure redistribution and self-reported comfort and discomfort scores of adults with mobility problems who remain seated for extended periods of time. A mixed methods approach was taken. This paper focuses on the qualitative data, as quantitative data is reported elsewhere (Bartley and Stephens 2016).

Ethical approval was obtained from the University of Salford abiding to protocols relating to consent, recording, and storage of data. Purposive sampling and snowballing technique was used for participant recruitment via social media and presentations to the local user and carer group. Using inclusion/exclusion criteria five men and seven women, aged from eighteen to eighty-four (five wheelchair users) were recruited.

Each participant was randomly allocated one of three trial chairs to use and evaluate for one week in their own home. On day one baseline demographic information (gender, age, weight, height, body mass index, and anthropometric measurements); recording of blood pressure, pulse, and respiratory rate; comfort and discomfort scores, and interface pressure measurements using the XSensor pressure mapping system (average and peak) in their current chair and in the trial chair. Repeated again on day one after a period of three hours using the trial chair. At day seven clinical observations, comfort and discomfort scores using an adapted version of the TAWC (Crane 2004), and interface pressure measurements were collected in the trial chair. A digitally recorded semi structured interview exploring comfort and discomfort scores and participants' opinions on the chair was also conducted. Burnard's (2000) stepped analysis process was used to analyse the transcribed qualitative comments and self-reported comfort/discomfort scores. This was in order to ensure a clear and auditable explanation of the data analysis process. Recurring themes from the data were: comfort, occupations, function, aesthetics, posture, and pressure redistribution.

Findings

Demographics varied across gender, age, height, weight, body mass index, average, and peak pressures, and General Discomfort Assessment (GDA) and Discomfort Intensity Rating (DIR).

Comfort

Although participants found it hard to express what comfort meant to them 92% participants reported the chairs as comfortable. When asked to expand on what comfort meant the respondents made reference to falling asleep in the chair, the chair being at the right temperature, having a positive effect, and stirring memories.

Occupations

Being able to carry out occupations such as watching television, reading and pursuing hobbies whilst seated in the chair was reported as important for 80% of participants. One participant who had not sat in a chair for three years described being able to do things that she would not have normally been able to do and for longer lengths of time.

Chair Function

Operational difficulties associated with chair function was re-counted by 75% of the participants. Illustrations were; removal of armrest for sideways transfers, being unable to fully extend the footrest, and tilting the chair back.

Aesthetics:

Participants differed in their opinions of the aesthetics of the chairs. 25% gave positive feedback in regards to the fabric, 50% disliked the colour and would have preferred if it matched their existing furniture. 17% favoured the manoeuvrability with the chair having wheels, and 50% stated that the chair had a clinical/nursing home appearance and this could be off putting in their own homes.

Posture:

92% of the participants made comments related to posture, extending from full body support, to specific areas being identified such as shoulders, feet, legs and back. There were specific comments from the participants in relation to full body (67%) and lumbar support (50%); 25% sitting down without supplementary back support; 25% still requiring an additional cushion in the lumbar region.

Pressure redistribution versus comfort/discomfort

The twelve participants reported the trial chairs as comfortable. However, the Hydrotilt chair recorded the highest interface pressures, but the lowest GDA and DIR scores. All chairs recorded low average pressures ($m=44.03\text{mm Hg}$).

Discussion

Many factors such as comfort, occupations, function, aesthetics, pressure redistribution and posture can assist the practitioner in correctly assessing and prescribing seating for the end user in order to reduce the risk of equipment being discarded. Comfort plays a major part in whether a piece of equipment is deemed acceptable and then utilised by the end user, yet is a concept often difficult to define (Crane and Hobson 2002). Comfort according to Cambridge Dictionaries Online (2016) can be defined as a 'pleasant feeling of being relaxed and free from pain.' Redfern (1976, p.211) described it as 'an abstract multidimensional concept that is difficult to define and measure'. Our study supports the literature as participants reported the chairs as comfortable although all had difficulty quantifying what this meant with one participant abandoning the chair. Pearson (2009) concurs with this stating that comfort is poorly understood and inconsistently evaluated. This may be overcome by using a validated tool and noting positive effects on clients whilst seated.

A significant number of participants reported being able to carry out occupations whilst seated in the chair such as reading, watching the television and participating in hobbies. A search of the literature has found no previous studies exploring the impact of specialist static chairs on occupation. One notable exception is expert opinion from Stockton, Gebhart, and Clarke (2009) who state that the ability to maintain occupations when seated is a key consideration.

Pinney et al. (2010) report that a chair should be easy for the user or caregiver to operate without the use of excessive moving and handling. However, a limitation of this report is that it is a buyer's guide. In our study the operation of the chair was reported by 75% of the participants who felt that the chair was difficult to adjust and would need to rely on someone else to do this. Most respondents reported the chair would be greatly improved if it had a powered facility e.g. tilt in space, leg raise, and recline. The participants did however find that the wheels on the chair were useful in relation to manoeuvrability. The researchers are aware that the company does manufacture a powered version of the chairs. This information was relayed to the participants who responded very positively towards it.

The majority of participants made comments related to posture which supports the work of Gagnon et al. (2005) who found that postural control affects a client's health, function, lifestyle and social relations. Most notable is the report of improved posture from sitting in the chair but also ranged from full body support to specific areas being identified such as shoulders, feet, legs and back. The Hydrotilt chair was recorded as the most comfortable chair, however, participants varied in their opinions of support. Two participants required additional lumbar support in the chair, conversely, two of the participants who used additional lumbar support in their own chair, did not need to use them. These findings illustrate that person centred assessment is essential, taking in to consideration previous medical history/pathology. It is reported that good seating conditions can lead to improvements in respiratory function, oral intake, digestion, motor skills, expiratory volume and expiratory time which can benefit the user physiologically and socially (Pinney et al. 2010). Notably in this study three participants reported that when sitting in the trial chair, they experienced a change in the position of their shoulders from protraction to

retraction, which aided respiration, posture, and feelings of well-being.

Two factors that demonstrate a deficit in the current literature in specialist static seating are: aesthetics of the chair and pressure redistribution. Firstly, aesthetics is an important consideration in regard to the users' motivation and satisfaction (Pinney et al. 2010). The participants in our study differed in their opinions of the fabric, the colour, the composition of the material, size of the chair, the visibility of the wheels, and appearance. This affected one of the participants resulting in total 'equipment abandonment' (Crane and Hobson 2002). Secondly this paper illustrates that low interface pressures do not always equate to optimum chair comfort. This is noteworthy in regard to assessment and prescription of chairs, as a more holistic approach needs to be considered. Whilst a static seat may offer improved pressure redistribution, other properties of the chair may deem it to be uncomfortable for the client.

Limitations of this study are the self-selecting participants and sample size, however, according to Parahoo (2014) data saturation can be achieved in qualitative studies with a sample size as small as six. This study highlights the need for further work in this area with a larger sample size from a diverse population who remain seated for long periods of time.

Conclusion

This study adds to the current literature that clinicians should consider comfort, pressure redistribution, aesthetics, function, posture, occupation, support and end user collaboration when assessing and prescribing seating for those who remain seated for extended periods of time.

References

1. Barbanel, J.C. (1991) Pressure Management. *Prosthetics and Orthotics International*. 15, pp.225-231.
2. Bartley, C., and Stephens, M. (2016) CareFlex HydroTilt, SmartSeat, and SmartSeatPro: evaluation of pressure and comfort. University of Salford: Salford. ISBN: 978-1-907842-88-7.
3. Burnard, P. (1991) A method of analysing interview transcripts in qualitative research. *Nurse Education Today*. 11 (6), pp. 461-466.
4. Cambridge Dictionaries Online (2016) Comfort. Retrieved 24/01/2016 from <http://dictionary.cambridge.org/dictionary/english/comfort>
5. Crane, B., and Hobson, D. (2002). The importance of comfort to wheelchair users - A preliminary study. Paper presented at The 18th International Seating Symposium, March 7 - 9, 2002, Vancouver, BC, Canada.
6. Crane, B. (2004) Development and validation of the wheelchair seating discomfort assessment tool. Retrieved from http://dscholarship.pitt.edu/6294/1/craneba_etd_2004.pdf
7. Collins, F. (1999). The contribution made by an armchair with integral pressure reducing cushion in the prevention of pressure sore incidence in the elderly, acutely ill patient. *Journal of Tissue Viability*, 9 (4), pp:133-137.
8. Collins, F. (2007). The Hydrotilt Armchair: meeting complex seating requirements. *International Journal of Therapy and Rehabilitation*, 14 (2), pp: 83-88
9. Defloor, T., and Grypdonck, M.H. (1999) Sitting posture and prevention of pressure ulcers. *Applied Nursing Research*. 12(3), pp.136-42
10. Giesbrecht, E. M., Mortenson, W. B., Miller, W.C. (2012). Prevalence and Facility Level Correlates of Need for Wheelchair Seating Assessment among Long Term Care Residents. *Gerontology*, 58, pp:373-384, DOI: 10.1159/000334819
11. Gil-Aguido, A., De la Peña- González, A., Del Ama-Espinosa, A., Pérez-Rizo., E., Díaz-Domínguez. E., and Sánchez-Ramos, A. (2009) Comparative study of pressure distribution at the user-cushion interface with different cushions in a population with spinal cord injury. *Clinical Biomechanics*. 24, pp. 558-563.
12. Guest, J.F., Ayoub, N., McIlwraith, T., Uchegbul, T., Gerrish, A., Weidlich, D., Vowden, K., and Vowden, P. (2015) Health economic burden that wounds impose on the National Health Service in the UK. *British Medical Journal*. Retrieved from <http://bmjopen.bmj.com/content/5/12/e009283.full.pdf+html>
13. Langemo, D.K., Melland, H., Hanson, D., Olson, B., and Hunter, S. (2000). The lived experience of having a pressure ulcer: a qualitative analysis. *Advances in Skin and Wound Care*. 13(5), pp.225-235
14. Kenney, S., Gowran R. J. (2014). Outcome measures for wheelchair and seating provision: a critical appraisal. *British Journal of Occupational Therapy*. 77 (2), PP: 67-77.
15. Kim, W.-J., and Chang, M. (2013). A Comparison of the Average Sitting Pressures and Symmetry Indexes between Air-adjustable and Foam Cushions. *Journal of Physical Therapy Science*, 25(9), pp.1185-1187. <http://doi.org/10.1589/jpts.25.1185>.
16. Moody, M., Evans, J., Fielden, S., Heelis, M., Dryer, P., Shapcott, N., Magee, P., Stefanov, D. (2015). Establishing user needs for a stability assessment tool to guide wheelchair prescription. *Disability and Rehabilitation: Assistive Technology*, pp: 1-9 DOI: 10.3109/17483107.2015.1063019
17. Parahoo, K. (2014). *Nursing research: principles, process and issues*. Palgrave Macmillan 3rd edition Basingstoke Hampshire.
18. Pearson, E.J.M. (2009) Comfort and its measurement – A literature review, *Disability and Rehabilitation. Assistive Technology*, 4(5), pp:301-310
19. Pinney, D., Clift, I., and Clift, M. (2010). *Buyers' guide: specialist seating for stroke patients in the acute hospital setting*. London: Department of Health.
20. Redfem, S.J. (1976). The comfort of the hospital bed. In Kenedi, R.M., Cowden, J.M., and Scales, J.T. (Eds.), *Bedsore Biomechanics*. Maryland: University Park Press.
21. Schein, R, M., Schmeler, M. R., Holm, M. B., Saptono, A., Brienza, D. (2010). Telerehabilitation Wheeled Mobility and Seating Assessments Compared With In Person. *Archives of Physical Medicine and Rehabilitation*. 91, pp:874-878.
22. Stockton, L., Gebhardt, K.S., Clarke, M. (2009). Seating and pressure ulcers: Clinical practice guideline. *Tissue Viability Society*. Retrieved from <http://www.thinkpressurecare.co.uk/media/8775/tvsseatingandpressureulcerguidelines.pdf>
23. Stockton, L., and Rithalia, S. (2008) Is dynamic seating a modality worth considering in the prevention of pressure ulcers? *Journal of Tissue Viability*. 17 (1), pp:15-21

IC49: Custom Molded Seating: Back to the Basics

Jill M. Sparacio, OTR/L, ATP/SMS, ABDA

Custom molded seating can be an intimidating option in the provision of seating and wheeled mobility services. Bottom line, it is only as good as the shape captured; it requires a certain level of knowledge and creates accountability for the seating team. Because of this investment in the process, it is often overlooked or thought of as a last resort for individuals with varying postural needs. Recent developments in the ease of capturing shapes have simplified the process however basic knowledge of posture and the ability of the team to execute a successful mold remain basic to the process.

To clarify, the type of seating being addressed is indirectly molded custom seating. The desired shape is created from the consumer's body with some type of simulator and then captured through some type of medium (plaster cast, digital systems, etc). This differs from directly molded seating as the shapes and contour are created against the consumer's actual body (foam in place type components).

Traditionally, custom molded seating has been reserved for individuals with limited movement and significant skeletal asymmetries. Through different manufacturing approaches, the trend is shifting as custom molded seating can benefit those with varying presentations including those who sit independently to those who rely on the provision of imposed external support for the maintenance of an upright posture. Consideration of its use should include those who are independent in their activities of daily living as well as those who have varying degrees of need. The provision of external custom molded support can facilitate one's ability to actively participate in functional tasks. Other key benefits can include improved visual orientation, oral motor and respiratory function as well as the maintenance of skin integrity. On the other side, custom molded seating should never be restricting to active movement and function.

Cost is another deterrent for the use of custom molded seating. This, however, is not a valid reason to avoid custom molded. If an involved, multi-component system is required for postural support, by the time all necessary components are added, the cost for a modular system can often exceed that of custom molded.

When evaluating for custom molded seating, there are many custom molded seating manufacturers to choose from. Features need to be matched based on client evaluation and specific product features. Although each manufacturer has specific techniques and procedures, there are many commonalities when capturing the shape. The actual molding process, no matter which manufacturer is selected, should be a simple process. The seating team needs to have familiarity with the selected manufacturer, and preferably be certified in the process. Most manufacturers offer certification processes to insure proper use of their systems.

No matter which manufacturer is selected, the process for molding follows a similar progression. Success relies on proper orientation and alignment of the consumer's pelvis as a basis for support. Information gathered during the evaluation process reveals the desired orientation, the need for correction or accommodation and the need for total contact versus key points of control. Angles and orientation also have to be gathered at this time, looking specifically at the consumer's goals for seating. From an anterior/posterior perspective, the pelvis to thigh angle traditionally dictates the seat to back angle. But consider that the pelvis to thigh angle might be very different than the trunk to thigh angle; consideration of this impacts upper trunk and head/neck orientation. If these angles are not considered, successful positioning may not be gained. From a different perspective, a pelvic obliquity that is not corrected or properly supported will impact upper trunk and head alignment or the frontal trunk angle (correlation between the pelvis and the sternal notch). If the balance between correction and accommodation is not respected, issues will remain unsolved. This is where custom seating tends to "fail"; when correction cannot be maintained or tolerated, the consumer will find a way to move into his "personal posture" for comfort, giving the appearance that the custom seating is not right. Instead, it was the process that failed, not the actual cushions.

The process for capturing a shape needs to begin at the pelvis and move cephally and caudally, medially to laterally. Once the pelvis is stabilized, the shaping needs to work up the consumer's body with key areas of support in mind. If support or contact does not offer a benefit, reconsider its use. Consider the lateral supra-pelvic region. If contact is provided here, lateral bending of the trunk is significantly limited. If contact is not provided here, an individual with poor trunk control will have no choice but to lean into whatever support surface they can find, usually the lateral thoracic supports. Once leaning starts, concern is voiced and the lateral thoracic support is lowered, only to find the leaning to exaggerate. Again, if key areas are provided with contact and support, the posture above and below that point can benefit.

The orientation of all body segments needs to be considered before the shape capture is completed. As previously mentioned, if there is a support surface that does not offer support or benefit, does the surface need to be there? Surfaces should not be included for the sake of symmetry. On the other hand, a surface might be needed that does not offer postural support but has another function. For example, with an individual with a surgically stabilized spine, a right lateral thoracic support might be beneficial not as a support but vital as a prop for enhanced upper extremity function. All supports need to be discussed during the evaluation process as well as the molding process, insuring a need is being met.

Once the shape capture is completed, the shapes need to be analyzed to make sure they are properly contoured. Rounded shapes are desired instead of more squared off areas. Evaluation of the seat shape should reveal matching anatomy including ischial tuberosities, greater trochanters and rounded shaping from the seat portion into the molded lateral thigh supports. The seat to back transition needs to look like a body, not a disjointed system. In the back, key areas to check include the lateral supra-pelvic region, insuring contour

that matches the client's body. As noted, contact here is often key to a successful upper trunk and head position. A back that is relatively flat with lateral thoracic supports will not provide the contact and support needed.

Obviously, custom molded seating needs to be properly installed in a mobility base. Without respect for angles and dimensions, success will not occur. Documentation during the evaluation and clinical reasoning at the time of delivery is mandatory.

Conclusion:

Custom molded seating is only as good as the shape that is captured. Ultimately, the key to successful shape capturing is in the hands of the seating team. Instead of thinking it is a last resort, the use needs to be carefully matched to clients during the evaluation process, insuring that all information is gathered for success. Many individuals can benefit from the use of custom molded seating; it should be considered for varying levels of clients with varying presentations. If used before asymmetries are fixed, could it decrease problems down the road? A fine line is needed between accommodation and correction with respect to the client's "personal posture". While concern for cost is always a consideration, comparisons need to be made with component seating systems prior to making a final decision. Often times the custom molded is no more expensive and can offer improved function. During the molding process, care needs to be given to where and what type of support is provided, making sure that support surfaces are effective and necessary. The pelvis, as in most seating evaluations, is the point of origin with contact moving towards the client's head and toes, medially to laterally. Once completed, the shapes need to be examined to insure that the result will meet the client's goals as outlined in the evaluation. Ultimately, the key to successful shape capturing is in the hands of the seating team that is involved.

Resources:

1. Waugh, K. (2013). A Clinical Application Guide to Standardized Wheelchair Seating Measures of the Body and Seating Support Surfaces. Denver, CO: Assistive Technology Partners.
2. Sparacio, J. (2014, May 12). Clinical Considerations of Custom Molded Seating. Lecture presented at Canadian Seating and Mobility Conference in Toronto, Ontario.
3. Laurence, S. (2007). Custom Seating – Who, What, Where, When and Why Not. 23rd International Seating Symposium. Retrieved from http://www.iss.pitt.edu/ISS_Pre/ISS_Pre_Doc/ISS_2007.pdf

IC50: Power Adjustable Seat Height is Both Reasonable and Necessary!

Julie Piriano, PT, ATP/SMS

There is a misconception that power seat elevation is not covered by third party payors, which is inaccurate. This course will examine the clinical benefits and research in support of a power height adjustable seat, provide clinicians with practical tools to evaluate and document the need for this power seat option; and assist the supplier in reading and interpreting the information in the medical record to determine when to provide a power seat elevation system.

This session is supported by a company with reported interest in the sale of Assistive Technology products. The content has been reviewed by ISS personnel and determined to be appropriate for continuing education purposes.

Learning Objectives:

Upon completion of this session, attendees will be able to;

- List at least four clinical benefits of power adjustable seat height.
- Discuss the evidenced-based research that applies to the clinical decision-making process in the selection of a power adjustable seat height system.
- Identify at least two third party payors that will consider a highly functional power seat elevator for coverage and payment.

References:

1. Yoshioka, S., Nagano, A., Hay, D. C., & Fukashiro, S. (2014). Peak hip and knee joint moments during a sit-to-stand movement are invariant to the change of seat height within the range of low to normal seat height. *BioMedical Engineering OnLine*, 13(27).
2. Arva, J., Schmeler, M., Lange, M., Lipka, D., & Rosen, L. (2009). RESNA Position on the Application of Seat-Elevating Devices for Wheelchair Users, *Assistive Technology*. 21(2), 69-72.
3. Centers for Medicare and Medicaid Services (2016). Local Coverage Determination
4. Wheelchair Options/Accessories (L33792) Retrieved from www.cms.gov

IC51: Advanced Mobility Skills Training for Manual Wheelchair Users

Kendra Betz, MSPT, ATP

Objectives:

Upon completion of the session, participants will be able to:

- Discuss 5 fundamental mobility skills for manual wheelchair users.
- Describe optimal rear wheel position in 2 planes.
- Review mobility skills progression from basic propulsion to advanced wheelies.
- Identify two resources for objectively evaluating mobility skills.

Individuals who use a manual wheelchair (mwc) as a primary means of mobility require comprehensive clinical education and training to support mastery of advanced mobility skills for life participation. Acquisition of wheeled mobility skills supports maximized independence, safety and quality of life. Specific education and skills training can decrease the risk of injury while optimizing functional skills which ultimately supports the mwc user to lead a healthy, active and productive lifestyle. Critical education and training for manual wheelchair users includes wheelchair configuration recommendations, mobility progression from basic propulsion to advanced skills in varied environments, transfer techniques, wheelchair management such as stowing in a vehicle, travel and equipment maintenance. Too often, many of these critical education topics are neglected when mwc's are provided to either novice or experienced wheelers.

When issuing a wheelchair, it's imperative to provide and review information in the Owner Manual, also known as the User Guide or Instructions for Use. Awareness of topics covered in the manual promotes efficient management of the wheelchair, encourages safe operation, and highlights needs for routine maintenance which are all important considerations. However, individuals who use a mwc as a primary means of mobility require comprehensive education and training that extends far beyond the information provided in the wheelchair Owner Manual. As one example, mwc users often experience upper limb pain and injury that can result in significant functional impairment with a negative impact on quality of life (1). Specific skills training and education can decrease the risk of injury while optimizing functional ability and independence which ultimately supports the mwc to participate in meaningful activities and lead a healthy and productive lifestyle.

The aim of this session is to empower rehabilitation professionals to understand and provide comprehensive skills training critical for all manual wheelchair users. Guidance will be offered for efficient education methods and practical training techniques. Case examples with photos and video will be utilized to demonstrate key points. Pertinent research findings in conjunction with clinical experience will be incorporated throughout the presentation to facilitate

evidence based practice in providing appropriate education and training for manual wheelchair users. Highlighted topics will include the following:

Manual Wheelchair Selection & Configuration

While an extensive array of commercially available options exist, acquisition of optimized mobility skills is supported by a mwc that is made of lightweight, high strength materials and can be fully customized for the user. Critical configurations include seat width and depth, front and rear seat to floor heights, back angle, back height, frame lengths, front rigging configuration, wheel base orientation, and wheel position. Before initiating training for wheeled mobility skills, whether entry level propulsion or advanced wheelies in varied environments, the rear wheel position must be positioned as far forward as possible (and safe) in the horizontal dimension, with vertical and lateral orientation optimized (2-12).

Wheelchair Mobility Progression

Every mwc user requires education and training for using the wheelchair effectively including basic propulsion for getting from point A to point B, turning, opening and closing doors, navigating typical and unique indoor and outdoor settings, varied environments, uneven terrain, inclines, thresholds, curbs, steps, stairs, and advanced wheelie skills. Identifying elements of wheeled mobility skills training for new wheelchair users is highlighted as "an important step in preventing future health and participation restrictions" (13). While it's expected that a novice mwc user will benefit from training and practice, recent research demonstrates that individualized who have been experienced mwc users for many years still benefit from customized mobility skills training (14). Consideration of how mwc users use their wheelchairs throughout the day, in slow short bouts, guides determination for mobility skills training for maneuverability (15). When pushing forward across distances, propulsion with smooth long strokes that limit high impact on the pushrim and minimize frequency is recommended for efficiency and upper limb preservation (1, 16). The Wheelchair Skills Program is an open-source tool for assessing and training wheelchair skills for mwc users with varied experience levels (17-18).

Transfer Techniques

The active mwc user will move from his/her wheelchair to and from varied heights and surfaces including vehicles, floor and other equipment. Independence is maximized when the individual can transfer safely from either the right or left. Training approaches should emphasize upper limb protective strategies and biomechanically advantageous techniques (i.e. "keep it down" approach). As an example, transfers from a forward flexed position are optimal (19), and level or downhill transfers are recommended (20). The Transfer Assessment Tool (TAI) supports objective evaluation of transfer quality and guides treatment planning and progression for transfer skills (21).

Equipment Management

In addition to managing basic mwc functions, maneuvers and positioning in varied environments, active mwc users often transfer to a vehicle seat for driving and require training support for recommended methods to manage and stow the wheelchair in a vehicle. Managing other mobility equipment and supplies (i.e., sports equipment) while seated in a wheelchair requires creative problem solving, practice, and patience.

Travel & Leisure:

Advanced mobility skills from a mwc also include navigating public transportation, hotels, and less than 'accessible' environments such as recreational settings. Transportation options include buses, shuttles, taxis, taxi "alternatives" (i.e., Uber, Lyft) airplanes, trains, and boats. Specific education and practice with various forms of travel is always helpful. As an example, reviewing expectations for air travel before a first flight is highly recommended, to include transfers to/from aisle chairs, directing others for appropriate assistance, equipment management, stowage of wheelchairs in the cargo hold and "first on/last off" awareness. Strategies for maneuvering in hotel rooms include removing bathroom doors and rearranging furniture to improve accessibility. Endless options exist for sports & recreation participation with good mobility skills and awareness of available adaptations.

Equipment Maintenance:

Every mwc user must be aware that routine maintenance is required and the ability to perform and/or direct simple repairs is imperative. Consistent attention and correction is recommended for rear wheel alignment, caster function, tire pressure, and equipment hygiene (keep it clean!) Knowing how to change a tire and being prepared to change or repair a tire is a requirement. The effects of less than adequate tire pressure on wheelchair function has been demonstrated (22,23). A Wheelchair Maintenance Training Program (WMTP) is being developed and refined to efficiently teach wheelchair maintenance skills to clinicians, end users and caregivers (24).

Advanced mobility skills training empowers the mwc user with optimized independence, long term health through pain an injury prevention, and meaningful participation in productive and enjoyable activities. All mwc users, ranging from novice to highly experienced wheelers, can benefit from learning new mobility skills and incorporating them into everyday life (25).

References

1. Consortium for Spinal Cord Medicine. Clinical Practice Guideline: Preservation of Upper Limb Function Following Spinal Cord Injury. Paralyzed Veterans of America; April 2005.
2. Brubaker CE. Wheelchair prescription: an analysis of factors that affect mobility and performance. *J Rehabil Res Dev.* 1986; 23:19-26.
3. Hughes CJ, Weimar WH, Sheth PN, Brubaker CE. Biomechanics of wheelchair propulsion as a function of seat position and user-to-chair interface. *Arch Phys Med Rehabil.* 1992;73:263-9.
4. Masse LC, Lamontagne M, O'Riain MD. Biomechanical analysis of wheelchair propulsion for various seating positions. *J Rehabil Res Dev.* 1992; 29:12-28.
5. Boninger ML, Cooper RA, Koontz AM, Chan L. Manual wheelchair pushrim biomechanics and axle position. *Arch Phys Med Rehabil.* 2000; 81:608-13.
6. Mulroy S, Newsam C, Gutierrez D, Requejo P, Gronley J, Haubert L, Perry J. Effect of fore-aft seat position on shoulder demands during wheelchair propulsion: part 1. A kinetic analysis. *J Spinal Cord Med.* 2005; 28(3):214-21.
7. van der Woude L, Veeger D, Rozendal R, Sargeant T. Seat height in handrim wheelchair propulsion. *J Rehabil Res Dev.* 1989; 26(4):31-50.
8. Richter W. The effect of seat position on manual wheelchair propulsion biomechanics: a quasi-static model-based approach. *Med Eng Phys.* 2001; 23(10):707-12.
9. Trudel G, Kirby L, Ackroyd-Stolarz S, Kirkland S. Effects of rear-wheel camber on wheelchair stability. *Arch Phys Med Rehabil.* 1997; 78(1):78-81.
10. Veeger D, van der Woude L, Rozendal R. The effect of rear wheel camber in manual wheelchair propulsion. *J Rehabil Res Dev.* 1989; 26(2):37-46.
11. Faupin A, Campillo P, Weissland T, Gorce P, Thevenon A. The effects of rear-wheel camber on the mechanical parameters produced during the wheelchair sprinting of handibasketball athletes. *J Rehabil Res Dev.* 2004; 41(3B):421-428.
12. Medola FO, Elui VM, Santana CS, Fortulan CA. Aspects of manual wheelchair configuration affecting mobility: a review. *J Phys Ther Sci.* 2014; 26:313-318.
13. Morgan KA, Engsberg JR, Gray DB. Important wheelchair skills for new manual wheelchair users: health care professional and wheelchair user perspectives. *Disabil Rehabil Assist Technol.* 2017 Jan;12(1):28-38.
14. Kirby RL, Mitchell D, Sabharwal S, McCranie M, Nelson AI. Manual Wheelchair Skills Training for Community-Dwelling Veterans with Spinal Cord Injury: A Randomized Controlled Trial. *PLoS One.* 2016; 11(12) 1-20.
15. Sonenblum S, Sprigle S. Wheelchair use in ultra-light wheelchair users. *Disabil Rehabil Assist Technol.* 2016 Jul 19:1-6. [Epub ahead of print]
16. Boninger ML, Souza AL, Cooper RA, Fitzgerald SG, Koontz AM. Propulsion patterns and pushrim biomechanics in manual wheelchair propulsion. *Arch Phys Med Rehabil.* 2002; 83:718-23.
17. Kirby RL, Smith C, Parker K, McAllister M, Boyce J, Rusthon PW et al. The Wheelchairs Skills Program Manual. Published electronically by Dalhousie University, Halifax, Nova Scotia, Canada. www.wheelchairskillsprogram.ca/eng/manual/php/. Accessed November 2016.

-
18. Kirby RL, Woroby LA, Cowan R, Presperin Pederson J, Heinemann AW, Dyson-Hudson TA, Shea M, Smith C, Rushton PW, Boninger ML. Wheelchair Skills Capacity and Performance of Manual Wheelchair Users with Spinal Cord Injury. *Arch Phys Med Rehabil.* 2016; 97:1761-1769.
 19. Gagnon D, Nadeau D, Gravel L, Noreau C, Lariviere. Biomechanical analysis of a posterior transfer maneuver on a level surface in individuals with high- and low-level spinal cord injuries. *Clinical Biomech.* 2003; 18:319-31.
 20. Wang Y, Kim C, Ford III H, and Ford Jr. H. Reaction force and EMG analyses of wheelchair transfers. *Perceptual and Motor Skills.* 1989; 26:31-50.
 21. McClure LA, Boninger ML, Ozawa H, Koontz A. Reliability and validity analysis of the transfer assessment instrument. *Arch Phys Med Rehabil.* 2011 Mar;92(3):499-508.
 22. Sawatzky B, Kim W, Denison I. The ergonomics of different tyres and tyre pressure during wheelchair propulsion. *Ergonomics.* 2004; 47(14):1475-83.
 23. Sawatzky B, Miller W, Denison I. Measuring energy expenditure using heart rate to assess the effects of wheelchair tyre pressure. *Clin Rehabil.* 2005; 19(2):18
 24. Toro ML, Bird E, Oyster M, Worobey L, Lain M, Bucior S, Cooper RA, Pearlman J. Development of a wheelchair maintenance training programme and questionnaire for clinicians and wheelchair users. *Disabil Rehabil Assist Technol.* 2017 Jan 27:1-12. [Epub ahead of print]
 25. Hosseini S, Oyster ML, Kirby RL, Harrington AL, Boninger ML. Manual wheelchair skills predict quality of life and community reintegration in persons with spinal cord injury. *Arch Phys Med Rehabil.* 2012; 93:2237-2243.

Contact:

Kendra Betz

University of Pittsburgh/Veterans Health Administration
Denver, CO
United States
Kendra.Betz@comcast.net

IC52: Meeting the Unmet Need: Encouraging and Educating Therapists

Amber Lea Ward, MS, OTR/L, BCPR, ATP/SMS

Stacey Mullis, OTR/L, ATP

Background

Seating and wheeled mobility can touch every area of OT/PT practice from pediatrics to geriatrics and every type of disability. Since mobility directly relates to all areas of daily function it is critical that even new graduate and generalist OT and PT practitioners understand basic seating and wheeled mobility concepts which will allow for optimal functionality and independence of clients. The management, training, evaluation and provision of seating and wheeled mobility is a natural fit for therapists and assistants. Yet, due to lack of knowledge, time and other constraints, it is sometimes difficult for practitioners to pursue further skills in the area of seating and wheeled mobility. There is a significant unmet public need for practitioners experienced in seating and wheeled mobility to perform evaluations, training and product selection to guide consumers.

Methods

Based on the following description of Occupational Therapy from AOTA, it can be determined that seating and wheeled mobility naturally fits in the OT frame of reference: "Occupational therapy services typically include: an individualized evaluation, during which the client, family, and occupational therapist determine the person's goals, customized intervention to improve the person's ability to perform daily activities and reach the goals, and an outcomes evaluation to ensure that the goals are being met and/or to modify the intervention plan based on the patient's needs and skills. Occupational therapy services may include comprehensive evaluations of the client's home and other environments, recommendations for adaptive equipment and training in its use, training in how to modify a task or activity to facilitate participation, and guidance and education for family members and caregivers" (Occupational Therapy: Improving Function while Controlling Costs).

Similarly, the APTA definition of Physical Therapy supports the provision of seating and wheeled mobility services: "PTs examine each individual and develop a plan, using treatment techniques to promote the ability to move, reduce pain, restore function, and prevent disability. In addition, PTs work with individuals to prevent the loss of mobility before it occurs by developing fitness- and wellness-oriented programs for healthier and more active lifestyle" (Who Are Physical Therapists?).

The role of a therapist is a key component to the provision of seating and wheeled mobility equipment, and often necessary for reimbursement. Translating therapy evaluation results to the seated posture and selecting the most appropriate equipment considering the patient's prognosis is expected of the therapist. Yet, OT/PT students typically receive one day of instruction on the topic, or a few hours discussing cushions and other equipment. The context of this provision and the process is not clearly outlined, resulting in the OTs/PTs not clearly understanding the importance of their roles in seating and wheeled mobility. Without this understanding, the end users suffer by receiving inappropriate equipment.

The Clinician Task Force, headed by Laura Cohen and Barbara Crane surveyed groups of PT and OT programs to determine how much education is dedicated to seating and wheeled mobility. The results indicate an average of 8-10 hours of total instruction. The majority of this content is instructed by a chosen faculty member who may or may not have experience in seating and wheeled mobility.

In circumstances where end users are sent to seating clinics, the end user typically has to wait an average of 2-3 months to be seen. There is a shortage of therapists specializing in this area, resulting in long wait lists, and travel to get to the clinic. Many end users requiring a proper evaluation are not able to get to a clinic. Many vendors are also frustrated by the inability to find a therapist willing to complete a seating and mobility evaluation without the end user travelling hundreds of miles.

Findings

Options for each seating professional to help:

- Supplier- Host educational offerings at low cost, partner with schools for tours and to show product, guest lecturing for schools, equipment education, seek out interested therapists, get a booth at local/state conferences
- ATP- Constantly educate therapists/students on product/choices/decision making, let therapists know about CE opportunities, let students shadow, give webinars/guest lecture, and connect inexperienced therapists with seasoned seating therapists.
- Manufacturer- Host education offerings/factory tours, create webinars, new product demo, partner with OT/PT researchers, reach practitioners at local/state/national conferences, and partner with seating therapists to develop educational programs for universities and/or therapy groups.
- Seating Therapist/Assistant- Guest lecture or teach AT classes at OT/OTA or PT/PTA programs, take students for shadow, volunteer, level 1 or non-traditional level 2 fieldwork, offer CE events through state organization or through employer, speak at state and national conferences, join and be active with, give webinars, make sure SWM is a priority for education and national organization, offer shadowing opportunities to generalist therapists, educate at referral sources

Discussion

There are several existing resources available to therapists to improve their knowledge and comfort level with provision of seating and wheeled mobility. For example, the Clinician Task Force, specifically Laura Cohen and Barbara Crane, surveyed groups of PTs and PT programs to determine how much education is dedicated to seating and wheeled mobility. The results indicate an average of 8-10 hours of total instruction. The majority of this content is instructed by a chosen faculty member who may or may not have experience in seating and wheeled mobility. These findings were part of a grant request to the Nielsen foundation by Cohen and Crane to develop a standardized “plug and play” seating and wheeled mobility curriculum for PT/PTA programs. The grant was awarded in September of 2015 and a curriculum is currently being developed using the World Health Organization’s Beginner and Intermediate Training Modules. Other resources will also be discussed for each seating professional to feel empowered in educating therapists in seating and wheeled mobility.

Conclusion

There is a need for a discussion about how each seating professional (supplier, ATP, manufacturer, seating therapist/assistant) can get involved in promoting the need for knowledge and experience, as well as generating excitement in practitioners to assist clients in this area. Professionals in seating and wheeled mobility need options for educational opportunities, job shadowing and fieldwork, experiential learning, teaming with educators and healthcare centers, and other ways to train therapists. There are options for all service provider team members to assist educators, students and therapists in learning skills and competency in this area.

References

1. Arledge, S., Armstrong, W., Babinec, M., Dicianno, B., Digiovine, C., Dyson-Hudson, T., Pederson, J., Piriano, J., Plummer, T., Rosen, L., Schmeler, M., Shea, M., Stogner, J. (2011). RESNA Wheelchair Service Provision Guide. Retrieved May 5, 2016 from www.resna.org.
2. Minkel, J. (2012). Seating and Mobility Evaluations for Persons with Multiple Sclerosis. Retrieved May 6, 2016 from www.Nationalmssociety.org.
3. Best, K.L., Miller, W.C., Routhier F. (2015). A description of manual wheelchair skills training curriculum in entry-to-practice occupational and physical therapy programs in Canada. *Disability Rehabilitation Assistive Technology*. 10(5):401-6.
4. Greer, N., Brasure, M., Wilt, T.J. (2012). Wheeled Mobility (Wheelchair) Service Delivery: Scope of the Evidence. *Annals of Internal Medicine*.156(2):141-146.
5. Occupational Therapy: Improving Function While Controlling Costs. (n. d.). American Occupational Therapy Association. Retrieved October 31, 2016 from www.aota.org.
6. Who Are Physical Therapists? (n. d.). American Physical Therapy Association. Retrieved October 31, 2016 from www.APTA.org.

7. Clinician Task Force. (2015). Nielsen Foundation Awards Grant to Develop Wheelchair Service Training Program for Clinicians Working with Individuals with Spinal Cord Injury. [Press release]. Clinician Task Force. Retrieved October 31, 2016, from Rehabtechconsultants.com
8. Wheelchair Service Training Package – Intermediate Level (WSTP-I). (n. d.). World Health Organization. Retrieved November 1, 2016 from www.who.int/disabilities/technology/wheelchairpackage/en/
9. Wheelchair Service Training Package - Basic Level. (n. d.). World Health Organization. Retrieved November 1, 2016 from www.who.int/disabilities/technology/wheelchairpackage/en/

IC53: Seating the 'Unseatable'

Brenlee Mogul-Rotman, B.Sc.OT, OT
Reg. (Ont.), ATP/SMS
Stefanie Sukstorf Laurence, B.Sc.OT,
OT Reg. (Ont.)

Learning Objectives

Participants will be able to list 3 goals of the mat assessment. Participants will be able to identify importance of defining generic features of a seating system based on assessment. Participants will be able to discuss steps in problem-solving to match client needs and product options.

Ever have the sinking feeling when you meet a client that you have absolutely no idea where to start? Every client presents with their own unique issues; some are physical, some are behavioural, some are environmental related. A good outcome for a prescription takes all factors into consideration and strikes a balance to accommodate as many issues as possible. The core tenants of best practice in the prescription of a seating and mobility system are assessment, goal setting, matching client need to equipment parameters, evaluation and follow up. Utilizing the best practice, problem-solving path as it applies to any client, those that appear straight forward, complex or 'unseatable', whatever the reason can have a successful outcome. The follow case studies are examples of the application of these principles.

Case #1 -- Gary G:

Gary is a client who is unable to sit mainly due to pain. Because of the chronic nature of his pain, he suffers from other conditions such as skin/tissue breakdown, limited endurance and decreased overall strength. Gary is not able to complete daily tasks and spends most of his time in his worn out lift chair or on the sofa. He is not able to sleep in his bed for any extended period of time. He is isolated at home and has limited mobility.

A thorough assessment revealed equipment needs for the bed/mattress, transfers, bathroom as well as mobility. Because the client is able to ambulate short distances, these issues were never addressed. The client has deteriorated over time and his functional abilities have also declined significantly.

This client has become 'unseatable'. Through the use of equipment in all areas of his home, he is now able to sit, change positions independently, transfers safely, protect his skin and tissues and access his home environment as well as the community.

Client condition:

Injured at work 1987. Cervical and lumbar degenerative disc disease. L5-S1 microdiscectomy 1988. L5-S1 laminectomy 2000. C7 discectomy/laminectomy 2001.

Pain upper body, lower body, neck and back. Debilitating pain. Limitations to strength and sensation of lower extremities. Legs 'give out' without notice. Incontinence, history of pressure injuries and current pressure injury on left buttock. Left foot drop.

Functional limitations to strength range of motion, endurance. Cannot sit, cannot lie comfortably; spends most of his time in his lift chair in agony. Changes positions frequently.

Mobility and seating: power mobility. Had a chair in the past, has not had a power chair in 7 years (was stolen, never replaced). Ambulates short distances with cane; unsafe, inconsistent, frequent falls, limited balance. Unable to complete daily functional tasks. No community access due to mobility limitations, pain and limited endurance

Current equipment:

Lift chair - old and worn out, has numerous pillows on seat and obus forme on back.

Bed - electric bed with mattress that does not gatch/bend when head/feet features are used. Uncomfortable and unsafe. Not providing pain management or pressure management.

No mobility device.

Stall style shower with small step, but no bath chair.

Outcome:

- Bed - V4 React Mattress replacement with 2 ROHO mattress sections (pelvic area and heel area).
- Superpole for safety in transfers from bed
- Bath chair for safety when showering
- Lift chair with high-end memory foam and full features. Legrest extension to fit lower body length appropriately.
- Power wheelchair: Front wheel drive for access and manoeuvrability. Power seat elevation, power tilt, recline and elevating legrests for positioning options and pain management/pressure management. Anterior tilt for transfer assist.
- High profile ROHO Quadro cushion, Corpus back support and head support. Transfer handles on chair. Memory seating programmed.

Case #2 -- Fabio:

Fabio is a young man who suffered a brain injury in 2006. He is cared for primarily by his mother and attends physiotherapy (with different therapists), massage therapy and various programs. He is never on his own, his mother performs all of his care throughout the day.

This client is 'unseatable' as the goals of the therapists vs. the mom/client differ. The physiotherapist works on optimal alignment, reduction of spasticity and tone and attempts to reduce contractures and maintain range of motion. The

physio would like the client to be seated in custom molded seating to attempt to lock in the optimal position achieved in treatment. Fabio's mom wants him to sit well, but be able to move himself. She wants him to foot propel within the home (for short distances) and she does not want Fabio to be locked in place. If Fabio is seated in custom molds and does move due to spasticity and tone or to function, then he will not be utilizing the custom curves and potentially could be at higher risk of pain, tissue/skin breakdown and postural deformity.

Client condition:

Brain injury 2006.

No ambulation, severe high tone and spasticity. Limited range of motion upper extremities and lower extremities. Wears AFOs bilaterally. Left side of pelvis rotated forward, left pelvic obliquity, falls to the left. Rib hump larger on right side.

Current equipment:

Sits in manual tilt/recline chair with modular cushion and back support. Uses 4 pt. pelvic positioning belt and complex head support.

I
n sitting, right leg adducts and crosses over left leg, client falls to left, slides out of seat

Physiotherapist recommends custom molded seating to 'lock in' posture and alignment and control tone. Mom wants client to be able to move, to foot propel (with left foot), wants his legs separated and for client to change his position throughout the day. She regularly repositions him and he is never on his own.

Outcome:

- New chair not considered/does not meet funding agency criteria at this time.
- Modular cushion- Action LP2. Cushion has a low profile to ensure foot propulsion. Cushion incorporates a bit of gel to reduce some shear/friction. To add small, removable wedge under cushion at front so that optimal foot positioning is maintained when static and wedge removed for foot propulsion.
- Aeromesh calf panel, Bodypoint 4-point belt, Whitmyer SOFT Dual sub-occipital head support (tried Adjustaplush)
- Trufit Max back support with ability to adjust for shape of rib hump
- Bodypoint Upper body harness to be used when client needs to be more static

Case #3 – Adrian

Adrian is a 44 year old male who lives at home with his mother, who provides all of his care. Mother is devoted to his care, proud of the fact that he has never has surgery, and requires no medications. Adrian is reported to become agitated when in is chair not able to tolerate sitting in it for very long, and tending to fall to his right side.

On initial presentation Adrian appeared unseatable due to the severity of his left leg adduction. Mother reports that the removal of the pommel during the creation of his last seating system and lack of stretching during her absence due to medical issues, have resulted in his presentation. Mother's goal is to have Adrian sit 'normally'.

Client condition:

Cerebral palsy, developmental delay, non-verbal but very inquisitive, dependent for all of his activities of daily living.

Pelvis and spine can easily be positioned in midline. Fair head control and active use of upper extremities, although not purposeful. Right lower extremity able to approach 90 degree hip flexion, with fixed 90 degree knee and ankle flexion, but with adduction minimally correctable away from midline. Left lower extremity tight in full adduction, hip and knee flexion, with minimal ability to move the leg away from his pelvis.

Current equipment:

18" Quickie Iris (8 years old?) with custom laminar foam seat and back, and custom leg pad with additional custom removable pads. Deep seat well sits 2.5" forward of back rest such that client sits in recline with minimal back contact. Footrest hangers cut off of wheelchair frame and custom footbox mounted midline from seat pan. Seat cushion bolted to chair and covers difficult to remove for laundering. Custom fabricated headrest is wide/deep and difficult to see around.

Mother's goal is to have Adrian sit comfortably in chair with legs in neutral. She is frustrated at having so many pieces to deal with when getting him in and out of the chair, and the difficulty in moving the chair.

Outcome:

- 14" Quickie Iris with one contracture leg rest with angle adjustable plate and heel loop to support right leg, angle adjustable stroller handle
- Contour U seat and back cushion, both in aluminum pans to allow removal of back and seat covers for cleaning and mount of left leg support.
- Whitmyer Adjustaplush headrest to contain his head but not block his line of sight.
- Bodypoint 2-point padded belt, Daher chest harness for use outdoors only
- Invacare Matrx Elan headrest with standard pad, mounted to CU seat pan
- Extra wide arm pads (full length left, desk length right) on cantilever arms

While mom's goal was to get Adrian's leg back to midline, she understood that this was not immediately achievable. She was delighted to see Adrian comfortable, seating simplified, chair easily maneuverable, and leg support adjustable to match his ROM.

References

1. Arledge, S., Armstrong, W., et al (2011). RESNA Wheelchair Service Provision Guide. Arlington VA. Retrieved from www.resna.org
2. Waugh, K. & Crane, B., (2013). A Clinical Application Guide to Standardize Wheelchair Seating Measures of the Body and Seating Surfaces. Revised Edition. Denver, CO.
3. Laurence, S. & Mogul-Rotman, B., The Mat Assessment – Getting the Information You Actually Need. (handout) Presentation at Ontario Society of Occupational Therapists annual conference, Toronto, September 2012.

Contact Information

Brenlee Mogul–Rotman:

brenlee.mogul-rotman@permobil.com

Stefanie Sukstorf Laurence:

slaurence@motionspecialties.com

IC54: How Much Hip Abduction is Optimal in Sitting, Standing and Lying for Children with Cerebral Palsy?

Ginny Paleg, PT, DScPT

Tom Hetzel, PT, ATP

Lynore McLean, PT, BScPT

Melissa Tally, PT, MPT, ATP

Erin Pope, PT, MPT

The literature clearly documents the development of hip displacement and dislocation in children with cerebral palsy (CP) (Murray & Robb, 2006; Speigel & Flynn, 2006). Children with CP are born with “normal hips” and yet, these hips can progress to displacement as early as 2-3 years (Hägglund, Lauge-Pedersen, & Wagner, 2007). Rates of hip displacement are directly related to Gross Motor Function Classification System (GMFCS) level (Soo, et al., 2006) ranging from 0% for GMFCS level I to 90% for GMFCS level V [note: in Sweden where they’ve had a hip surveillance program for 20 years, this number was more recently reported as 49% for GMFCS level V (Hägglund, Alriksson-Schmidt, Lauge-Pedersen, Rodby-Bousquet, Wagner, & Westbom, 2014)]. If not managed, hip displacement/dislocation and its resulting pain can have a significant negative impact on participation, activity, sitting ability, sleep, and care-giving (Galland, Elder, & Taylor, 2012; Dischof & Chirwa, 2011). Management of hip displacement/dislocation primarily involves medication and surgery.

Following corrective hip surgery, orthopedic surgeons commonly apply a hip spica cast or splint set in 60 degrees of total hip abduction for the initial recovery period and request further seating modifications to “increase theommel size” and “seat the child with his hips in abduction”. Despite a literature search and interviews with a dozen pediatric orthopedic surgeons, no basis for this position has been found. Common themes were “best angle to elongate adductor muscles”, “achieves optimal coverage of the femoral head by the acetabulum” and “that’s what they taught me in my residency”.

Recent publications specifically used 60 degrees of hip abduction in a standing device when studying the impact of standing on hip location and hip adductor extensibility (Martinsson & Himmelmann, 2011; Macias-Merlo, Bagu-Calafat, Girabent-Farrés, & Stuber, 2015a; Macias-Merlo, Bagu-Calafat, Girabent-Farrés, & Stuber, 2015b). When the authors were asked why they chose that amount, Martinsson stated “that’s how far the stander went” and Macias stated “that’s what the orthopedists recommend”. The manufacturers of the standing frame used in the Martinsson,

et al. (2011) study were asked why the stander is able to position a child in 30 degrees of hip abduction on each side. They replied, “That’s what the therapists requested.” Piccolini, et al. (2016) published the results of a study on the benefits of sitting in hip abduction, Hankinson, et al. (2002) advocated lying in hip abduction and Poutney, et al. (2002 & 2008) showed to best support hip health, a child with CP must sit, stand and lie in abduction. All of these studies are lower levels of evidence, American Academy of Cerebral Palsy and Developmental Medicine (AACPDM) levels of evidence III-V (see Additional Resources 1), or “yellow” light evidence” (Novak, 2012). Despite the lack of strong supporting evidence in the literature, there is a consistent trend towards positioning children with CP in hip abduction.

We recommend that clinicians review the document, Positioning for Children GMFCS IV-V: Focus on Hip Health (2014) (see Additional Resources, 2) and consider applying these concepts when positioning children with CP. The data from the Surveillance Program for Cerebral Palsy, CPUP (www.cpunet.se), shows that a postural management program that includes sitting, standing and lying in abduction as part of a comprehensive hip and whole body surveillance program can positively impact hip & spine health.

Every child with motor impairments or risk for deformity should be enrolled in a hip surveillance or a “whole child” (i.e. includes gross motor, fine motor, tone management, spine, and hip) surveillance program by one year of age, even before a formal diagnosis of cerebral palsy is received. Positioning in abduction should be initiated for all children with abnormal muscle tone in the lower extremities, and for children not sitting by 9 months. It should be continued for those individuals who are at risk for hip displacement. As the body of literature grows and the impact of positioning on hip health is better studied and understood, these recommendations will continue to evolve.

References:

1. Bischof, et al. (2011). Daily care activities and hip pain in non-ambulatory children and young adults with cerebral palsy. *Journal of Pediatric Rehabilitation Medicine: An Interdisciplinary Approach*, 4, 219-223.
2. Galland, B. C., et al. (2012). Interventions with a sleep outcome for children with cerebral palsy or a post-traumatic brain injury: A systematic review. *Sleep Medicine Reviews*, 16, 561-573. doi: 10.1016/j.smr.2012.01.007
3. Hägglund, G., et al. (2007). Characteristics of children with hip displacement in cerebral palsy. *BMC Musculoskeletal Disorders*, 8(101) doi: 10.1186/1471-2474-8-101
4. Hägglund, G., Alriksson-Schmidt, A., Lauge-Pedersen, H., Rodby-Bousquet, E., Wagner, P., Westbom, L. (2014). Prevention of dislocation of the hip in children with cerebral palsy: 20-year results of a population-based prevention programme. *The Journal of Bone & Joint Surgery*, 96-B, 1546-52. doi: 10.1302/0301-620X.96B11.34385

5. Hankinson, J. et al. (2002). Use of a lying hip abduction system in children with bilateral cerebral palsy: A pilot study. *Developmental Medicine & Child Neurology*, 44, 177-180.
6. Macias-Merlo, L., Bagur-Calafat, C., Girabent-Farrés, M., & Stuberg, W. A. (2015a). Effects of the standing program with hip abduction on hip acetabular development in children with spastic diplegia cerebral palsy. *Disability and Rehabilitation*, 38(11), 1075-1081. doi:10.3109/09638288.2015.1100221
7. Macias-Merlo, L., Bagur-Calafat, C., Girabent-Farrés, M., & Stuberg, W. A. (2015b). Standing Programs to Promote Hip Flexibility in Children With Spastic Diplegic Cerebral Palsy. *Pediatric Physical Therapy*. doi:10.3109/09638288.2015.1100221
8. Martinsson, C., et al. (2011). Effect of weight-bearing in abduction and extension on hip stability in children with cerebral palsy. *Pediatric Physical Therapy*, 23, 150-157. doi: 10.1097/PEP.0b013e318218efc3
9. Murray, A. W., et al. (2006). The hip in cerebral palsy. *Current Orthopaedics*, 20, 286-293. doi: 10.1016/j.cuor.2006.06.011
10. Picciolini, O., et al (2016). Can we prevent hip dislocation in children with CP? Effects of postural management. *European Journal of Physical and Rehabilitation Medicine*, May 2016 [Epub ahead of print] <http://www.minervamedica.it>
11. Pountney, T., et al. (2002). Management of hip dislocation with postural management. *Child: Care, Health and Development*, 28(2), 179-185.
12. Pountney, T., et al. (2008). Hip subluxation and dislocation in cerebral palsy – a prospective study on the effectiveness of postural management programmes. *Physiotherapy Research International* 149(2), 116-127.
13. Soo, B., et al. (2006). Hip Displacement in cerebral palsy. *The Journal of Bone and Joint Surgery*, 88 (1), 121-9
14. Spiegel, D. A., et al. (2006). Evaluation and treatment of hip dysplasia in cerebral palsy. *Orthopedic Clinics of North America*, 37, 185-196. doi: 10.1016/j.ocl.2005.11.001
15. Macias-Merlo, L., Bagur-Calafat, C., Girabent-Farrés, M., & Stuberg, W. A. (2015). Effects of the standing program with hip abduction on hip acetabular development in children with spastic diplegia cerebral palsy. *Disability and Rehabilitation*, 38(11), 1075-1081. doi:10.3109/09638288.2015.1100221
16. Macias-Merlo, L., Bagur-Calafat, C., Girabent-Farrés, M., & Stuberg, W. A. (2015). Standing Programs to Promote Hip Flexibility in Children With Spastic Diplegic Cerebral Palsy. *Pediatric Physical Therapy*. doi:10.3109/09638288.2015.1100221
17. Novak, I. (2012). Evidence to practice commentary: The evidence alert traffic light grading system. *Physical and Occupational Therapy in Pediatrics*, 32(3), 256-259. doi:10.3109/01942638.2012.698148

Additional Resources:

1. AACPD Methodology to Develop Systematic Reviews of Treatment Interventions (Revision 1.2) 2008 Version (<https://www.aacpdm.org/UserFiles/file/systematic-review-methodology.pdf>)
2. Positioning for children in GMFCS levels IV and V: Focus on Hip Health (2014). <http://www.childdevelopment.ca/GMFCSHipHealth/GMFCSHipHealthClinicalTool.aspx>

IC55: Adaptive Bathroom Equipment for Adults

Elaina M. Halkiotis, MOT, OTR/L, ATP

Practice Area

Independence Care System (ICS) is a managed Medicare and Medicaid program in New York City. The population treated is adults with physical disabilities and chronic conditions. ICS funds wheeled mobility devices for in-home and community use, as well as adaptive bathroom equipment. Therapists at ICS perform in-clinic seating and mobility evaluations and home visits for wheelchair/scooter accessibility and bathroom assessments. This combination of in-home and in-clinic services provides a holistic view of each case to ensure the wheeled mobility device prescribed meets their in-home and community mobility needs, as well as maximizes their ability to participate in Mobility Related Activities of Daily Living (MRADLs).

Background

Therapists at ICS treat members with a diverse array of diagnoses, clinical presentations, and bathroom set-ups. Finding a bathroom equipment solution that fits in the space available, meets the member's seating and positioning needs during bathing and toileting, and that is user-friendly for caregivers to operate can be a challenge. This presentation describes several cases with members who have different physical disabilities and bathroom layouts, who require individualized equipment solution to meet their bathing and toileting needs. This presentation is intended to show other clinicians different types of adaptive bathroom equipment available and how it can be applied in a variety of settings and practical situations.

Intervention Schedule and Location

Intervention for these cases typically begins with an in-clinic seating and mobility evaluation. Once identifying their postural and skin protection needs and establishing a plan for ordering a new or modifying their existing wheeled mobility device, a home visit for bathroom accessibility was scheduled. Home visits typically involved two to three sessions.

The first home visit was a general accessibility assessment to determine bathroom layout and dimensions. This information was used in conjunction with the information about their transfer status and wheeled mobility device to determine appropriate demonstration equipment. The second appointment was usually conducted with a therapist and wheelchair repair technician. The technician would transport and set-up the demonstration equipment in the bathroom. The therapist would physically transfer the member into the system, transfer the member over the toilet and into the bath/shower area, then return them to bed or the wheelchair. The findings of this demonstration appointment were used to

determine the new bathroom equipment specifications. The third session was for equipment fitting, training, and delivery. Follow-up sessions for further training and adjustments were scheduled as needed.

Equipment Used

- Raz Designs SP for man with paraplegia from a T5 incomplete spinal cord injury to self-propel into a roll-in-shower and over his toilet.
- NuProdx multiCHAIR 6000 used for woman with quadriplegia from multiple sclerosis to be wheeled into her shower stall (with beveled edge entry) and over her toilet.
- Raz Designs AT used for C5 complete spinal cord injury to be dependently wheeled over his toilet, into his roll-in-shower, and be tilted posteriorly for postural support while bathing.
- Raz Designs SP-600 for 6'4" tall man (1.93m), 313 pounds (142kg) with paraplegia from multiple sclerosis to independently wheel himself over the toilet and into his roll-in-shower.
- Activaaid 480-20 with a right-sided seat opening for a man with paraplegia from a T8 complete spinal cord injury. The man was able to wheel over the toilet, perform independent digital stimulation with his right hand, and wheel in and out of his roll-in-shower independently.
- NuProdx 6200tilt used for a man with dementia who is 6'5" (195cm) and 220 lbs (100kg) and is cared for by his wife who is approximately 5'4" (162cm) tall and 140 pounds (63kg). This system allowed the man to be wheeled backward into the bathroom and over his toilet, then be transferred laterally into the tub for bathing.
- Go Mobility CST was used for a woman with quadriplegia from a C5 incomplete spinal cord injury to be transferred from bed into this system, then wheeled over the toilet for toileting and into the tub for bathing.
- NuProdx mc6000 for a man with paraplegia from a T7 complete spinal cord injury to independently transfer from the bed to the rolling bathing/commode system, propel himself into the bathroom, over the toilet, then into the bathtub.

Member Generated Strategies

Sometimes the members and their families had created their own bathroom adaptations to enable bathing and toileting. Some of these include:

installation of a floor drain and a removable hand-held shower set-up at the sink for bathing in the middle of the bathroom when it was not possible to access the tub
building a ramp with bilateral railings to traverse the 6" (15cm) step up into the bathroom
fabricating an in-tub net on which to lay for bathing a man with muscular dystrophy in a position he finds most comfortable

Findings

Most members were very pleased with their new bathroom equipment. For many it was the first time they could take a real shower instead of a bed bath. The first few times using the transfer tub system equipment takes a little more time, but with use the process becomes more efficient for the member and the caregiver. Occasionally replacement seat cushions or backrests are required on the bathroom equipment. These parts are ordered, then interfaced onto the existing base. The shower chairs we issue typically last the members five to seven years.

Conclusion

It is important for clinicians to consider the bathing and toileting needs of patients. Being aware of equipment available will assist your clinical reasoning and decision making when prescribing equipment. Exploring alternative funding options may help to make access to adaptive bathroom equipment a reality for your clients too.

References

1. Brad E. Dicianno MD, Jenny Lieberman MSOTR/L, ATP, Mark R. Schmeler OTR/L, ATP PHD,, Ana Elisa Schuler P. Souza PHD, PT, Rosemarie Cooper MPT, ATP, Michelle Lange OTR, ABDA, ATP/SMS, Hsinyi Liu PTPHD & Yih-Kuen Jan PTPHD (2015) Rehabilitation Engineering and Assistive Technology Society of North America's Position on the Application of Tilt, Recline, and Elevating Legrests for Wheelchairs Literature Update, Assistive Technology, 27:3, 193-198, DOI: 10.1080/10400435.2015.1066657
2. Chan A, Heck CS. The Effects of Tilting the Seating Position of a Wheelchair on Respiration, Posture, Fatigue, Voice Volume and Exertion Outcomes in Individuals With Advanced Multiple Sclerosis. J Rehab Outcomes Meas. 1999;3(4):1-14.
3. Cook, AM & Polgar, JM. (2012). Essentials of Assistive Technology, St. Louis, MO: Elsevier.

IC56: An Online Wheelchair Maintenance Training Program for Clinicians

Sara Múnera, BS

Maria L. Toro Hernandez, PhD

Jonathan Pearlman, PhD

Background

According to the WHO, 1% of the world's population, or 75 million people, needs a wheelchair (World Health Organization, 2008). In the United States, approximately 3.6 million non-institutionalized adults use wheelchairs (Baum et al., 2012). The National Spinal Cord Injury Statistical Center describes an increase in the use of wheelchairs in people with spinal cord injury from 58.6% in the first year after injury, to 79.9% 30 years after injury. This Center has also shown that manual wheelchairs are the most common types, but that the use of power wheelchairs increases from 22.0% in year one after injury, to 41.9% in year 40 after injury (National Spinal Cord Injury Statistical Center, 2015).

The Convention on the Rights of Persons with Disabilities and the Standard Rules on the Equalization of Opportunities for Persons with Disabilities states that personal mobility is a right, a way to enjoy equal opportunities, and a way to ensure participation, independence, and social integration (United Nations, 2006; World Health Organization, 2008). Appropriate wheelchairs and their related services are the first step in accomplishing this right. The use of an appropriate wheelchair has a positive impact on the lives of people with disabilities; it decreases health complications such as pressure sores and contractures, and increases quality of life (World Health Organization, 2008). Appropriate wheelchairs can be a facilitator to social participation, but at the same time, can be a barrier. In fact, according to wheelchair users, inappropriate wheelchairs are the most common factor that limits their ability to participate in different environments (Chaves et al., 2004).

Similarly, wheelchair problems, such as maintenance and repairs, can have a negative impact in the user's life since the users can be injured and become unable to attend school or work (Mann, Hurren, Charvat, & Tomita, 1996). Research has shown an increase in wheelchair users reporting repairs, from 44.8% in 2009 to more than 63.8% in 2016 (McClure et al., 2009; Maria Luisa Toro, Worobey, Boninger, Cooper, & Pearlman, 2016; Worobey, Oyster, Nemunaitis, Cooper, & Boninger, 2012), suggesting an increase in wheelchair breakdowns. Nearly one-third (32.3%) of wheelchair users have experienced at least one adverse consequence as a result of the associated breakdown—such as being injured or stranded, or having reduced mobility (Worobey et al., 2012) and quality of life (Bourret, Bernick, Cott, & Kontos, 2002).

Research has suggested that providing more information to wheelchair users on how to perform wheelchair maintenance and how to do routine wheelchair checkups might be a way to solve this issue (Mann et al., 1996). When maintenance is performed on wheelchairs, the number of accidents and injuries for wheelchair users is reduced (Hansen, Tresse, & Gunnarsson, 2004).

An in-person training program to teach clinicians how to perform maintenance on wheelchairs, so they can train wheelchair users, was developed. The training material was based on websites, books, wheelchair maintenance technicians' experiences, owner's manuals, and other materials (Maria L Toro et al., 2015). The Wheelchair Maintenance Training Program (WMTP) was launched in the US in the summer of 2014, and was conducted with positive outcomes proving that it is an effective program to increase clinicians' training knowledge (Maria L Toro, 2015). The next step of the project was to develop an online version of the WMTP, making it available to a larger population of trainees.

Online learning or eLearning is defined as "An approach to teaching and learning (...) that is based on the use of electronic media and devices as tools for improving access to training..." (Sangrà, Vlachopoulos, & Cabrera, 2012). It increases access to education (Sinclair, Kable, Levett-Jones, & Booth, 2016), and it has been proven to be as effective as traditional learning, even when teaching practical skills (Ackermann et al., 2010; Maertens et al., 2016; Pham et al., 2016).

Development of the Online Program

The Online WMTP was developed in different phases through an iterative process. Table 1 summarizes the phases and results from each one.

Table 1. Online WMTP development process

Phase	Procedure	Results
Content translation	The in-person training program was made suitable for an online learning environment. The content was not modified, and the course activities were to be completed during the same amount of time as the in-person program.	Online materials and overview of the complete training program.
Internal review	The syllabus and one of the lectures were sent to wheelchair maintenance experts for review.	The organization of the material was modified for easier understanding, minor modifications were made in the way the syllabus was presented, and additional resources (videos) were created.
External review	The complete Online WMTP was reviewed by experts in e-learning and instructional design. Feedback was collected through a survey and an online synchronous meeting.	The software version used to create the content material was upgraded (Captivate 9). Each lecture was divided into smaller chunks to make it easier for participants to understand. More interactivity was added to the lectures and additional resources such as elective activities and a glossary terms were generated. Modifications were made in the questionnaires to make them more user-friendly.
Usability test	An end-user went through the complete Online WMTP to identify usability problems, collect qualitative and quantitative data and determine satisfaction with the program.	Strengths and weakness were acknowledged: The interactivity of the lectures, the optional videos, and the ease of use were strengths of the program. Most tasks were completed without errors. Modifications were made to provide more information on how to navigate the lectures.
Pilot	The program was piloted with 4 participants.	Participants completed all the lectures and assignments. There was an increase in knowledge, confidence, and capacity while performing wheelchair skills. Participants stated that the duration of the program was adequate; they valued peer interaction as a way to improve the learning process. Modifications were made before the implementation to increase peer interaction, social construction of knowledge and immediate feedback from trainers.

The Online WMTP has a three week duration in which participants review the learning materials and perform maintenance tasks on wheelchairs in pairs. The training starts when participants are enrolled in the Online WMTP. They review an orientation video and lecture, and participate on an introduction forum. During week one and two, they complete assignments on manual and power wheelchair maintenance and ask questions on a forum as a way to appropriate knowledge; other participants are encouraged to give feedback and problem-solve to answer common questions. Additionally, trainers give feedback on each participant's assignments. On the last week, participants review a lecture on how to train wheelchair users on the program and complete two assignments: one to increase their knowledge about repair resources available in their communities and another one to get familiar with the training materials and practice delivering a portion of the training. Once again, feedback from peers is requested and trainers emphasize important points with their comments. At the end of the program, an online synchronous meeting is held to reinforce correct maintenance techniques and answer questions in real time with visual feedback. Participants complete, before and after the training program, a wheelchair maintenance training questionnaire (WMT-Q) to evaluate their knowledge, confidence, and capacity while performing wheelchair skills. Table 2 summarizes the training activities performed by participants during each week.

Table 2. Online WMTP outline

Week	Activities
Week 1	- Demographics questionnaire - WMT- Q - Orientation Lecture - Manual Wheelchair Lecture - Manual Wheelchair Assignment
Week 2	- Power Wheelchair Lecture - Power Wheelchair Assignment
Week 3	- Logistics to deliver the training Lecture - Assignment - Synchronous meeting - WMT- Q

Significance and Future work

The online program will be implemented by the end of 2016 in different Spinal Cord Injury Model Systems to train trainers and receive feedback to keep improving the Online WMTP.

Having an online version of the WMTP can increase the number of trainers teaching wheelchair users how to perform maintenance on their wheelchairs. This can potentially reduce wheelchair related incidents such as tips and falls and being injured or stranded, and could increase social participation of wheelchair users, allowing them to fulfill their human rights.

Access to wheelchair-related education is a challenge particularly in developing countries. Translating the Online WMTP into other languages and making it appropriate for different cultures and settings should be a next step in this project.

References

- Ackermann, O., Siemann, H., Schwarting, T., Ruchholtz, S., Duisburg, K., & Fleetinsel, K. (2010). Effektives Training der chirurgischen Röntgenbefundung durch E-Learning in Orthopaedic Surgery, 348–352.
- Baum, C. M., Brault, M. W., Chang, F.-H., Wang, Y.-H., Jang, Y., Wang, C.-W., ... Eng, J. J. (2012). Americans with disabilities: 2010. *American Journal of Physical Medicine & Rehabilitation*, 92(4), 70–131. <http://doi.org/10.1046/j.1365-2648.2002.02104.x>
- Bourret, E. M., Bernick, L. G., Cott, C. a., & Kontos, P. C. (2002). The meaning of mobility for residents and staff in long-term care facilities. *Journal of Advanced Nursing*, 37(4), 338–345. <http://doi.org/10.1046/j.1365-2648.2002.02104.x>
- Chaves, E. S., Boninger, M. L., Cooper, R., Fitzgerald, S. G., Gray, D. B., & Cooper, R. A. (2004). Assessing the Influence of Wheelchair Technology on Perception of Participation in Spinal Cord Injury. *Archives of Physical Medicine and Rehabilitation*, 85(11), 1854–1858.
- Hansen, R., Tresse, S., & Gunnarsson, R. K. (2004). Fewer accidents and better maintenance with active wheelchair check-ups: a randomized controlled clinical trial. *Clinical Rehabilitation*, 8, 631–639.
- Maertens, H., Madani, A., Landry, T., Vermassen, F., Van Herzele, I., & Aggarwal, R. (2016). Systematic review of e-learning for surgical training. *British Journal of Surgery*. <http://doi.org/10.1002/bjs.10236>
- Mann, W. C., Hurren, D., Charvat, B., & Tomita, M. (1996). Problems with wheelchairs experienced by frail elders. *Technology and Disability*, 5(1), 101–111.
- McClure, L. A., Boninger, M. L., Oyster, M. L., Williams, S., Houlihan, B., Lieberman, J. A., & Cooper, R. A. (2009). Wheelchair repairs, breakdown, and adverse consequences for people with traumatic Spinal Cord Injury. *Archives of Physical Medicine and Rehabilitation*, 90, 2034–2038. <http://doi.org/10.1016/j.apmr.2009.07.020>
- National Spinal Cord Injury Statistical Center. (2015). 2015 annual statistical report for the Spinal Cord Injury model systems. Birmingham, Alabama.
- Pham, D., Hardcastle, N., Foroudi, F., Kron, T., Bressel, M., Hilder, B., ... Siva, S. (2016). A Multidisciplinary Evaluation of a Web-based eLearning Training Programme for SAFRON II (TROG 13.01): A Multicentre Randomised Study of Stereotactic Radiotherapy for Lung Metastases. *Clinical Oncology*, 28(9), e101–e108. <http://doi.org/10.1016/j.clon.2016.03.005>
- Sangrà, A., Vlachopoulos, D., & Cabrera, N. (2012). Building an Inclusive Definition of E-Learning: An Approach to the Conceptual Framework.
- Sinclair, P. M., Kable, A., Levett-Jones, T., & Booth, D. (2016). The effectiveness of Internet-based e-learning on clinician behaviour and patient outcomes: A systematic review. *International Journal of Nursing Studies*, 57, 70–81. <http://doi.org/10.1016/j.ijnurstu.2016.01.011>
- Toro, M. L. (2015). Development, implementation, and dissemination of a wheelchair maintenance training program. University of Pittsburgh.
- Toro, M. L., Oyster, M., Krobot, E., Worobey, L., Boninger, M., & Pearlman, J. (2015). Development of a wheelchair maintenance Training program and Wheelchair maintenance questionnaire. In RESNA.

-
15. Toro, M. L., Worobey, L., Boninger, M. L., Cooper, R. A., & Pearlman, J. (2016). Type and Frequency of Reported Wheelchair Repairs and Related Adverse Consequences Among People With Spinal Cord Injury. <http://doi.org/10.1016/j.apmr.2016.03.032>
 16. United Nations. (2006). Convention on the rights of persons with disabilities and optional protocol. New York, NY: United Nations. Retrieved from <http://www.un.org/disabilities/convention/conventionfull.shtml>
 17. World Health Organization. (2008). Guidelines on the provision of manual wheelchairs in less-resourced settings. Switzerland.
 18. Worobey, L., Oyster, M., Nemunaitis, G., Cooper, R., & Boninger, M. L. (2012). Increases in wheelchair breakdowns, repairs, and adverse consequences for people with traumatic spinal cord injury. *American Journal of Physical Medicine & Rehabilitation*, 91(6), 463–469.

PS7.1: Interrater reliability of the Wheelchair Components Questionnaire for Condition

Karen Rispin, MS

John DiFrancesco

Kristopher Riseling, PT

Larry Raymond, DPT

Introduction

Wheelchairs are known to improve participation and mobility; however, breakdown and wear reduces the value of wheelchair and may cause injury [1]. The situation is particularly challenging in low resource areas where access to appropriate wheelchairs and to wheelchair repair is often very limited [2]. Studies using validated outcomes measures are known to enable effective use of limited funds and are badly needed in low resource areas [3]. Many wheelchair outcomes measures are aimed primarily at assessing the appropriateness of a wheelchair to its user. In these measures, durability issues may be masked by other aspects of appropriateness. However, durability is of key importance to wheelchair manufacturers seeking to improve design [4]. In low resource areas wheelchair users often encounter rolling environments which challenge wheelchair durability such as gritty rough terrain, rocks and curbs. Durability may be tested in the laboratory using drop and double drum tests, but these do not perfectly reflect conditions in the field [5]. Wheelchair maintenance condition after a period of use sheds light on wheelchair durability and on the availability of parts and the local repair regime. The Wheelchair Components Questionnaire for Condition (WCQc) was developed to assess the maintenance condition of wheelchairs after a period of use and has been utilized in several studies [5]. To confirm the value of WCQc data, it is essential that the reliability of the measure is tested [6]. Earlier studies confirmed discriminatory validity and test re-test reliability, but interrater reliability had not yet been confirmed [7]. Inter-rater reliability is a common reliability test for professional report outcomes measures in which two or more professionals evaluate a variable group of 30 or more subjects. An intra-class correlation coefficient (ICC) of above 0.7 between the raters is generally considered evidence of reliability [8]. The purpose of this study was to investigate the interrater reliability of the WCQc.

Methods

The WCQc consists of eight questions, each concerning different wheelchair components. Each component is rated on a 10 cm visual analogue scale with emoticons and school grades as anchors. For each component, raters are asked to provide a qualitative comment explaining the reason behind their rating.

Two physical therapists who have had more than five years of experience of working with wheelchairs in low resource areas evaluated a group of 46 wheelchairs. The raters did not communicate about their assessments or look at one another's scores until the study was complete. Each had a work area where they would evaluate a wheelchair. Individual wheelchairs went to raters based on the order of convenience so that no rater was sitting idle.

The study protocol was approved by the authors' university and the organization which provides therapy to the wheelchair users. Although wheelchair users were not directly part of this study, this study was done with a group of other studies that did include wheelchair users. Wheelchair users and their guardians completed subject consent and assent. The study benefited wheelchair users because the protocol included wheelchair repair and modification for wheelchairs which had been assessed.

Analysis of data began with the measurement of the visual analogue scale line from the lower end to the mark made by raters. The scores were entered into spreadsheets and data was testing for normalcy using the Anderson Darling test. ICC was calculated for the mean score for each wheelchair by each rater.

Results

The ICC value for the two raters was 0.82, indicating good reliability. Both raters evaluated 46 wheelchairs. All wheelchairs were of types intended for distribution in low resource areas. Manufacturers included Hope Haven, Wheelchairs for Kids, Free Wheelchair Mission, Motivation, Association for the Physically Disabled of Kenya and Whirlwind.

Conclusion

This study confirms that the WCQc is a reliable way of assessing the maintenance condition of a wheelchair. Work is underway to provide the WCQc as a downloadable computer program to reduce the need to manually measure the visual analogue score questions, and to provide a digital and printable report for individual wheelchairs. The WCQc can be used in studies of cadres of wheelchairs of the same type in low resource areas to give feedback to manufacturers on which parts are wearing out prematurely. Wheelchair provision at some clinics in low resource areas is dependent on the shipment of container loads of wheelchairs on a periodic basis. The WCQc could be completed for wheelchair users before such a shipment is loaded to predict the need for replacement chairs. It could also be used in clinics with a more continuous model of wheelchair fitting to provide evidence of the need for the replacement of worn wheelchairs.

References

1. Worobey, L., Oyster, M., Nemunaitis, G., Cooper, R., & Boninger, M. L. (2012). Increases in wheelchair breakdowns, repairs, and adverse consequences for people with traumatic spinal cord injury. *American Journal of Physical Medicine & Rehabilitation*, 91(6), 463-469.
2. Jefferds, A. N., Beyene, N. M., Upadhyay, N., Shoker, P., Pearlman, J. L., Cooper, R. A., & Wee, J. (2010). Current State of Mobility Technology Provision in Less-Resourced Countries. *Physical Medicine and Rehabilitation Clinics of North America*, 21(1), 221-242.
3. Matter, R., Harniss, M., Oderud, T., Borg, J., & Eide, A. H. (2016). Assistive technology in resource-limited environments: a scoping review. *Disability and Rehabilitation: Assistive Technology*, 1-10.
4. Fitzgerald, S. G., & Kelleher, A. (2005). Durability of manual wheelchairs: A review. *International Journal of Therapy & Rehabilitation*, 12(12).
5. Reese, N., Rispin, K. (2015). Assessing wheelchair breakdowns in Kenya to inform wheelchair test standards for low-resource settings. Paper presented at the Rehabilitation Engineering and Assistive Technology Society of North America, Denver, CO
6. Jerosch-Herold, C. (2005). An evidence-based approach to choosing outcome measures: a checklist for the critical appraisal of validity, reliability and responsiveness studies. *The British Journal of Occupational Therapy*, 68(8), 347-353.
7. Rispin, K., Dittmer, M., McLean, J., Wee, J. (2016). Reliability and Sensitivity of the Wheelchair Components Questionnaire for Condition. Paper presented at the 32nd Annual International Seating Symposium, Vancouver, BC, Canada.

Author details:

Karen Rispin: Associate Professor, PI of the Wheels Project studies, LeTourneau University

John DiFrancesco: undergraduate student, LeTourneau University

Kris Riseling: Adjunct instructor, School of Rehabilitation Therapy, Queens University. PT at Providence Care, St. Mary's of the Lake Hospital.

Larry Raymond: Clinical Program Manager Center for Wound Healing, John Hopkins Medicine

Corresponding author

Karen Rispin; email: karenrispin@letu.edu

PS7.2: Proper Wheelchair Measurement and Fit

Rachel Arata-Maiers, OTS

Brian Zita, OTS

Ana Allegretti, PhD, OTR, ATP

According to the most recent report conducted by the U.S. Census Bureau, over 3.6 million Americans over the age of 15 years have used a wheelchair (Brault, 2012). The need for impaired mobility and wheeled accessibility is growing, however, individuals are frequently placed in inadequate seating positions and devices. Accurate measurement and fit are crucial to improving functional performance (Cooper, 2006; Sprigle, 2014). Proper seating ergonomics have been studied to determine normal body mechanics for comfort and prophylactic care of individuals (Boninger, 2000; Mercer, 2006). Many research studies have been conducted to provide wheelchair users with safe and functional devices for mobility and accessibility; however, individuals are frequently placed in incompatible chairs causing pain and dysfunction after repeated use. Although precise measurement and fit are essential, proper seat position and propulsion patterns are also fundamental to safe mobility and functional performance (Boninger, 2002; Woude, 2001). This paper summarizes research targeted at optimizing appropriate body mechanics and ergonomics to provide safe and functional mobility.

Learning Objectives:

Upon completion of this session, attendees will be able to;

- Define at least two aspects of proper wheelchair measurement and fit.
- List at least two types of available evidence on the impact of how important it is to prescribe a wheelchair that meets the needs of the patient for a better quality of life.
- Define one protocol for clinicians to have a proper understanding of wheelchair set-up for functional mobility for their patients.

References:

1. Boninger, M.L., Baldwin, M., Cooper, R. A., Koontz, A.M., & Chan, L. (2000). Manual wheelchair pushrim biomechanics and axle position. the American Congress of Rehabilitation Medicine and the American Academy of Physical Medicine and Rehabilitation. 81.
2. Boninger, M.L., Souza, A. L., Cooper, R. A., Fitzgerald, S. G., Koontz, A.M., & Fay, B. T. (2002). Propulsion patterns and pushrim biomechanics in manual wheelchair propulsion. Medical Engineering & Physics, 83.
3. Brault, M. W. (2012). Americans with disabilities. Current Population Reports. U.S. Department of Commerce Economics and Statistics Administration.

PS7.3: Wheelchair Skills Training: University Course vs. Boot Camp

Paula W. Rushton, OT, PhD

Genevieve Daoust, BS, OT

Introduction

Regrettably, of the ~197,560 Canadian manual wheelchair users (Smith, Giesbrecht, Mortenson & Miller, 2016) only 11%-55% receive wheelchair skills training (Charbonneau, Kirby & Thompson, 2013; Kirby, Keeler, Wang, Thompson & Theriault, 2015). Further, the training provided is focused primarily on basic mobility skills (e.g., moving forward), while more advanced skills, such as those required for community mobility (e.g., negotiating curbs), are seldom taught (Best, Routhier & Miller, 2015). Simply providing a wheelchair does not guarantee its safe and effective use. Without wheelchair skills training, there are important costs to the wheelchair user (e.g., decreased independence (Shields, 2004)) and society (e.g., caregiver burden (World Health Organization, 2011)).

One factor that is likely contributing to the low prevalence of wheelchair skills training is the lack of education provided to occupational therapy students. In Canada, there are 14 accredited occupational therapy programs. Of the 11 programs that responded to a recent survey (Best, Miller & Routhier, 2015), only 7 (63%) provided manual wheelchair skills training within their curriculum. Most of these programs (n=4) offered less than 5 hours of training and only 2 used a validated program.

One resource that is available for providing wheelchair skills training to occupational therapy students is the Wheelchair Skills Program (Kirby et al, 2016), a program based on rehabilitation, wheelchair and motor learning literature. When taught using a 'boot camp' type of format (e.g., 3-5 consecutive hours), the WSP has resulted in improvements among occupational therapy students in terms of wheelchair skill capacity (Coolen et al, 2004; Giesbrecht et al, 2015) and wheelchair confidence (Giesbrecht et al, 2015). However, use of the 'boot camp' approach for training occupational therapy students has also been shown to result in poor short- and long-term retention of the more advanced wheelchair skills (Kirby et al, 2016). This poor retention was likely the result of training many skills in a brief period of time, thus interfering with consolidation (Coolen et al, 2004). A more effective approach, in line with motor learning principles (Magill & Anderson, 2007) and as recommended in the WSP, may be to organize the training into several shorter sessions spread out over a longer period of time (i.e., distributed practice), rather than in a condensed fashion (i.e., massed practice), such as that provided with the 'boot camp' approach. Thus, the purpose of this study was to compare the effectiveness of wheelchair skills training offered to occupational therapy students using a condensed practice 'boot camp' approach

versus a distributed practice university course approach on wheelchair skills, wheelchair confidence and self-efficacy to test and train wheelchair skills.

Methods

Design

This study used a quasi-experimental, non-equivalent control group study design. It was approved by the Ste-Justine University Hospital research ethics committee. All participants provided informed consent.

Sample and Recruitment Procedure

The experimental group consisted of the 31 professional master's occupational therapy students of the University of Montreal who were taking the course "Occupational Therapy and Wheelchair Use" (January to April 2016). All students taking the course were invited to participate in this study and all accepted.

The comparison group consisted of 14 professional master's occupational therapy students of the University of Montreal and 14 occupational therapists who had graduated from the University of Montreal occupational therapy program within the preceding 8 months. These volunteer participants were recruited through two occupational therapy student Facebook groups "Ergothérapie 2011-2015" and "Ergo UdeM-cohorte 2016".

Intervention

Experimental group

The experimental group was trained during the course, "Occupational Therapy and Wheelchair Use". This course was 45 hours in length, with 1 3-hour class per week for 15 weeks. The 45 hours were used to cover the World Health Organisation's 8-step Wheelchair Service Provision Process (World Health Organization, 2008). Within these 45 hours, a total of 14 hours were dedicated to wheelchair skills testing and training education, using the Wheelchair Skills Program (WSP) version 4.3 (Kirby et al, 2016).

Comparison Group

The comparison group was trained using the 'boot camp' approach. Each participant attended a 6-hour boot camp taught by the same 2 instructors who taught the university wheelchair course. The boot camp consisted of a 1-hour lecture that provided an overview of the WSP and 5 hours of hands-on practical training.

Outcome Measures

Wheelchair Skills Test Questionnaire (WST-Q)

The WST-Q is a subjective, self-report measure of 34 wheelchair skills, ranging from moving forward a short distance to descending stairs (Mountain, Kirby & Smith, 2004). It has demonstrated reliability (Mountain, Kirby & Smith, 2004) and validity (Mountain, Kirby & Smith, 2004; Rushton, Kirby & Miller, 2012), and was administered and scored according to the WSP Manual (Kirby et al, 2016).

Wheelchair Use Confidence Scale (WheelCon)

The WheelCon, version 3.0 is a 65-item subjective, self-report measure of wheelchair confidence (Rushton, Miller, Kirby & Eng, 2013). It has demonstrated reliability and validity (Rushton, Miller, Kirby & Eng, 2013) and was scored using a 0 (not confident) to 100 (completely confident) response scale.

Self-Efficacy for Assessing, Training and Spotting wheelchair skills (SEATS)

The SEATS measures the confidence level of clinicians to assess, train, spot wheelchair skills using a 1 (not at all confident) to 5 (completely confident) response scale for 32 skills of the Wheelchair Skills Test.

Data Collection Procedure

Both the experimental and comparison group completed a demographic questionnaire. Both groups completed the WST-Q, WheelCon and SEATS prior to pre and post wheelchair skills training.

Data Analyses

Descriptive statistics were computed to describe the sample. The Shapiro-Wilk Test was used to determine the normality of the data. The differences between the experimental and comparison group were analyzed using an independent t-test (parametric data) and Mann-Whitney test (non-parametric data). The differences between pre and post training within groups were analyzed using a paired t-test (parametric data) and the Wilcoxon signed-rank test (non-parametric data). The level of significance was defined as $p < 0.05$. All statistical analyses were performed using SPSS, version 21 statistical software.

Results

In terms of demographics, groups were comparable in age (ranging from 21-43 years old) and sex (93% woman). There were differences between groups in that the comparison group was composed of both practicing clinicians and master's occupational therapy students.

In terms of outcomes, the baseline characteristics of the groups were comparable with respect to wheelchair confidence and self-efficacy to test, train and spot wheelchair skills. However, there were significant differences with respect to subjective assessment of wheelchair skills. Compared to baseline, both groups improved significantly in wheelchair skills and wheelchair confidence, as well as self-efficacy to test, train, spot wheelchair users and complete documentation ($p < 0.001$). Although a statistically significant difference was not found between the experimental group and comparison group after the wheelchair skills training, the experimental group scores were higher.

Discussion

This study contributes to the evidence regarding the effectiveness of wheelchair skills training for occupational therapy students and occupational therapists. It demonstrated that both a boot camp (massed practice) and a university course (distributed practice) approach improves wheelchair skill, wheelchair confidence and self-efficacy to test, train and spot wheelchair skills. That there was a trend towards higher scores for the experimental group post-training may indicate that a university course is more effective. Given that individuals tend to over-estimate their ability to perform wheelchair skills (Rushton, Kirby & Miller, 2012), an objective, performance-based measure of wheelchair skills (i.e., using the Wheelchair Skills Test) (Kirby et al, 2016) may provide a more accurate representation of the differences in wheelchair skill acquisition between a boot camp and university course approach. Future research using the Wheelchair Skills Test performance-based measure, as well as a measure of retention of skill may provide an enhanced understanding of the boot camp versus university course approach for occupational therapy students.

References

1. Best, K. L., Miller, W. C., Routhier, F. (2015). A description of manual wheelchair skills training curriculum in entry-to-practice occupational and physical therapy programs in Canada. *Disability and Rehabilitation: Assistive Technology*, 10(5), 401-406.
2. Best, K. L., Routhier, F., Miller, W. C. (2015). A description of manual wheelchair skills training: current practices in Canadian rehabilitation centers. *Disability and Rehabilitation: Assistive Technology*, 10(5), 393-400.
3. Charbonneau, R., Kirby, R.L., Thompson K. (2013). Manual wheelchair propulsion by people with hemiplegia: Within-participant comparisons of forward versus backward techniques. *Archives of Physical Medicine and Rehabilitation*, 94, 1707-1713.
4. Coolen, A. L., Kirby, R. L., Landry, J., MacPhee, A. H., Dupuis, D., Smith, C., ... MacLeod, D. A. (2004). Wheelchair skills training program for clinicians: a randomized controlled trial with occupational therapy students. *Archives of physical medicine and rehabilitation*, 85(7), 1160-1167.
5. Giesbrecht, E. M., Wilson, N., Schneider, A., Bains, D., Hall, J., Miller, W. C. (2015). Preliminary evidence to support a "boot camp" approach to wheelchair skills training for clinicians. *Archives of physical medicine and rehabilitation*, 96(6), 1158-1161.
6. Kirby, R.L., Keeler, L., Wang, S., Thompson K., Theriault, C. (2015). Proportion of wheelchair users who receive wheelchair skills training during an admission to a Canadian rehabilitation center. *Topics in Geriatric Rehabilitation*, 31(1), 58-66.
7. Kirby, R.L., Smith, C., Parker, K., McAllister, M., Boyce, J., Rushton, P.W., Routhier, F., Best, K.L., Mortenson, B., Brandt, A. (2016). Wheelchair Skills Program Manual, version 4.3. Available at: http://www.wheelchairskillsprogram.ca/eng/documents/version4.3.3/The_Wheelchair_Skills_Program_Manual.77_w_comments_and_highlights.pdf Accessed October 30, 2016.

-
8. Magill, R. A., & Anderson, D. (2007). Motor learning and control: Concepts and applications (Vol. 11). New York: McGraw-Hill.
 9. Mountain, A. D., Kirby, R. L., Smith, C. (2004). The Wheelchair Skills Test, version 2.4: validity of an algorithm-based questionnaire version. *Archives of physical medicine and rehabilitation*, 85(3), 416-423.
 10. Rushton, P. W., Kirby, R. L., Miller, W. C. (2012). Manual wheelchair skills: objective testing versus subjective questionnaire. *Archives of physical medicine and rehabilitation*, 93(12), 2313-2318.
 11. Rushton, P. W., Miller, W. C., Kirby, R. L., Eng, J. J. (2013). Measure for the assessment of confidence with manual wheelchair use (WheelCon-M) version 2.1: reliability and validity. *Journal of rehabilitation medicine*, 45(1), 61-67.
 12. Shields, M. (2004). Use of wheelchairs and other mobility support devices. *Health Reports*, 15(3), 37.
 13. Smith, E.M., Giesbrecht, E.M., Mortenson, W.B., Miller W.C. (2016). Prevalence of Wheelchair and Scooter Use Among Community-Dwelling Canadians. *Physical Therapy*, 96(8), 1135-1142.
 14. World Health Organization. (2008). Guidelines on the provision of wheelchairs in less resourced settings. Available at: <http://www.who.int/disabilities/publications/technology/wheelchairguidelines/en/>. Accessed February 17, 2015.
 15. World Health Organization. (2011). World Report on Disability. Geneva: World Health Organization.

Corresponding author:

Paula Rushton, OT, PhD

Assistant Professor

Université de Montréal, École de réadaptation

Centre de Réadaptation Marie Enfant, CHU Sainte-Justine

5200, rue Bélanger Est

Montréal, Québec H1T 1C9

Canada

Contact e-mail : pwrushton@gmail.com

Disclosure

We (Paula W Rushton, Genevieve Daoust) do not have an affiliation (financial or otherwise) with an equipment, medical device or communications organization.

PS7.4: Reliability of the Aspects of Wheelchair Mobility Protocol

Karen Rispin, MSc

Kara Huff

Joy Wee, MD, FRCPC, MSc

Introduction

The need for wheelchairs in low resource areas is great, yet funds and wheelchair types available are limited; therefore, comparative effectiveness studies are needed to enable effective use of limited funds [1]. Challenges to mobility in low resource areas include much time spent outdoors on rough surfaces, few ramps or wheelchair friendly spaces and crowded living spaces. Mobility can be measured using physical performance measures; however, validated physical performance measures are not primarily intended for comparative effectiveness studies [2]. The Aspects of Wheelchair Mobility Protocol (AWMP) was developed to be used in a repeated measures study design to provide comparative effectiveness data on wheelchair mobility [3]. Acceptable test re-test reliability generally requires an interclass correlation of greater than 0.7[4,5]. This study examines the test re-test reliability of the AWMP as a measure of mobility.

Methods

The AWMP includes measured tracks on each of the following rolling environments: outdoor unpaved rough surfaces; indoor smooth surfaces; tight spaces; and curbs. Participants roll on each track for four minutes and the distance traveled is recorded. Participants then complete a visual analogue scale question and provide an explanatory comment. At a boarding school for children with disabilities in a low resource area, a group of wheelchair users completed the protocol twice in their own wheelchairs at least one week apart. The study protocol was approved by the authors' universities and the organization providing rehabilitation to the participants. Participants and their guardians provided subject consent and assent. Preliminary versions of the AWMP included the use of heartrate monitors [3]. However, distance traveled was adequate to differentiate between wheelchair types, so the need for heartrate monitors was eliminated to make the AWMP more broadly applicable. Data was tested for normalcy and ICC was calculated using the SPSS statistical analysis program.

Results

Fifty wheelchair users completed the study (average age 17.3 SD \pm 1.75, gender 27M, 23F). The Anderson Darling test indicated that distance traveled and visual analogue score data sets were both suitable for parametric statistical analysis. Intra-class correlation coefficient was calculated for mean visual analogue scores (ICC = 0.80) and mean distance traveled on each of the iterations (ICC = 0.96).

Conclusion

Test re-test reliability of the AWMP as a measure of mobility was confirmed by ICC scores above 0.7. This study indicates that the AWMP provides a reliable assessment of mobility on four commonly encountered rolling environments. In large studies, the AWMP can be used in a repeated measures format to distinguish between the mobility facilitated by different wheelchair types. In a clinical setting, a client could be asked to complete the AWMP in available wheelchair options. This would provide objective data on the mobility facilitated to that client by each available wheelchair type. By eliminating the need to monitor heart rate in the protocol, the AWMP can be done in low resource areas without the need for extra equipment. The AWMP utilizes rolling environments found on location; therefore, set up would be somewhat different at each location. However, the protocol remains the same. Because of this variability, studies at other locations are desirable. Studies with participants of different ages and conditions are also suggested to confirm reliability with other populations of wheelchair users.

References

1. Matter, R., et al., Assistive technology in resource-limited environments: a scoping review. *Disability and Rehabilitation: Assistive Technology*, 2016: p. 1-10.
2. Kirby, R.L., Survey of Wheelchair Skills Tests: Making the Case for Broadening the Search and Assessment Criteria. *Clinical Rehabilitation*, 2011. 25(3): p. 287.
3. Rispin, K. and J. Wee, Comparison between performances of three types of manual wheelchairs often distributed in low-resource settings. *Disability and Rehabilitation: Assistive Technology*, 2015(0): p. 1-7.
4. Jerosch-Herold, C., An evidence-based approach to choosing outcome measures: a checklist for the critical appraisal of validity, reliability and responsiveness studies. *The British Journal of Occupational Therapy*, 2005. 68(8): p. 347-353.
5. Revicki, D., et al., Recommended Methods for Determining Responsiveness and Minimally Important Differences for Patient-Reported Outcomes. *Journal of Clinical Epidemiology*, 2008. 61(2): p. 102-109.

Author details:

- **Karen Rispin:** Associate Professor, PI of the Wheels Project studies, LeTourneau University
- **Kara Huff:** undergraduate student, LeTourneau University
- **Joy Wee:** Adjunct Assistant Professor, Department of Rehabilitation Therapy, Queens University

Corresponding author

Karen Rispin

E-mail: karenrispin@letu.edu

IC57: The Seating Clinic: Business Realities for Success

Tina Roesler, ABDA, MPT

Theresa F. Berner, MOT, OTR/L, ATP

In today's changing healthcare arena, many clinicians experience new pressures related to the business side of healthcare. While many therapists have entered their prospective fields with an altruistic view of their profession and what it means to help others, the realities of today's healthcare environment demands a knowledge of basic business concepts and funding. From personnel management to productivity and profitability, the demands on the Therapist Manager often extend beyond their comfort zone.

While many seating clinics have experienced cuts and decreases in facility support, it has become more important that the Therapy Manager become proactive in program development, marketing, and personnel management. One of the most important steps that the Therapy Manager can take is to develop a strong seating clinic team that includes various members of the medical facility staff, the complex rehabilitation supplier, and the manufacturer. Each player brings a unique set of skills to the team and allows the patient to gain multiple perspectives when making decisions about equipment.

This course will carefully outline the roles and responsibilities of each team member to identify the strength of the team. The course will also discuss and define multiple structures of how to set up a team environment so multiple continuum of care can be showcased. We will also discuss the leadership challenges that often need to be addressed when the Seating Clinic is evaluated in the context of the entire outpatient business center. The importance of the team and structure would not be successful if the clinician is not getting reimbursed for their time. Therefore structure and examples of billing models and treatment plans surrounding wheelchair clinic service delivery will be showcased. Clinicians routinely deliver services as a part of an inpatient and outpatient team with no concern of reimbursement, this course will correlate how seating clinics should not be any different. By the end of the course the audience will have several examples and options of how to develop a team to serve patients through a structured seating clinic model.

CPT DEFINITIONS AND GUIDELINES

Guideline for Seating and Positioning Clinical Time
PHYSICAL THERAPY and OCCUPATIONAL THERAPY

97001; 97003 Physical Therapy or Occupational Therapy Evaluation- This is an untimed code, billed as one unit.

Comprehensive Musculoskeletal and Neuromuscular Evaluation. The examination is to include: comprehensive history, performing a systems review and conducting tests and measures, (ROM, motor function, muscle performance,

joint integrity, neuromuscular status, and review of orthotic or prosthetic devices). The PT or OT will review the exam findings, determine a PT or OT diagnosis, determine prognosis and develop a Plan of Care that includes goals and expected outcomes, interventions to be used, and anticipated discharge plans.

If there are multi-site or multi system involvement then all conditions should be assessed at the initial eval. Evals that span over more than one day should be charged when the eval is completed. **DO NOT COUNT AS "THERAPY TREATMENT" THE ADDITIONAL MINUTES TO COMPLETE THE EVAL AT A DIFFERENT SESSION**

97002; 97004 Physical Therapy or Occupational Therapy

Re-evaluation- The PT or OT reexamines the patient to evaluate progress and to modify or redirect intervention and/or revise anticipated goals and expected outcomes. This code may be used more than once during a plan of care. Tests and Measures include but are not limited to those in a PT or OT Evaluation. The PT or OT must modify the plan of care as is indicated and support medical necessity of skilled intervention. Documentation must show significant change in the patient's condition that supports the need to perform a re-eval. If a patient is hospitalized during the therapy interval, a re-evaluation may be medically necessary if there has been significant change in the patient's condition which has caused a change in function, long-term goals, and/or treatment plan. **This is an untimed code, billed as one unit.**

THERAPEUTIC PROCEDURES-

Documentation **must support** the skilled nature of the therapeutic procedures and/or the need for establishment of a maintenance exercise program. The goals should be to increase functional abilities in self-care, mobility, or patient safety. Document the goals and type of procedures provided and/or exercise program devised and the major muscle groups treated. Physician or therapist required to have direct (one-on-one) patient contact.

When documenting document that you are doing the therapeutic exercise because of medical complications, the condition of the patient or complexity of the exercise employed, must be rendered by or under the supervision of a PT or OT. Include the patient's losses and/or dependencies in self-care, mobility, and safety. The possibility of adverse effects from improper performance of an otherwise unskilled service does not make it a skilled service. Provide documentation that supports why skilled therapy is needed for the patient's medical condition and/or safety. This info is usually provided in the eval and plan of care.

- Only the actual time of direct contact with the patient providing the service is covered for the **skilled care**.
- Time spent in documentation of services is part of the coverage of the CPT code; there is no separate coverage for time spent on documentation.

97110 Therapeutic Procedure, each 15 minutes-

Therapeutic exercise to one or more body parts to develop strength, endurance, ROM, and flexibility. May be described as active, active-assisted, or passive participation. Therapeutic exercises are reasonable and necessary for a loss of or decrease of joint motion, strength, functional

capacity or mobility, which has resulted from a specific disease or injury. The documentation must show objective loss of joint motion, strength, and mobility. Also included should be measurable indicators of functional loss of joint motion or muscle strength. Describe the impact of these limitations on the patient's life and how improvement of this will lead to improved function. Document that the patient is responding to the therapy and improving in function. Describe new exercises added, or changes made to exercises to show the skilled service required. Documentation must show that the exercises are being transitioned to a home exercise program.

97530 Therapeutic Activities, each 15 minutes- Must be direct 1:1 contact with provider and patient. The provider uses dynamic therapeutic activities designed to improve functional performance (lifting, pulling, bending, transfers, bed mobility, and overhead activities) in a progressive manner. These activities must always involve movement and are usually directed at a loss or restriction of mobility, strength, balance, or coordination.

97537 Community/Work Reintegration Training, each 15 minutes- (Shopping, transportation, money management, avocational activities, and/or work environment/modification analysis, work task analysis, use of assistive technology device/adaptive equipment)

The provider instructs and trains the patient in community reintegration activities (work task analysis, and modification, safe accessing of transportation) Not to be used for social outings.

- This code should be used when a patient is trained in the use of assistive technology to assist with mobility, seating systems and environmental control systems for use in the community.
- Coverage greater than 4-6 visits for community training should be justified by documentation to show the medical necessity of the length of treatment.

97542 Wheelchair Management (Assessment, fitting, training), each 15 minutes- Provider performs assessments, fitting, and adjustments, and instructs and trains the patient in proper wheelchair skills (propulsion, safety techniques) in their home, facility, work, or community environment. Typically 3-4 sessions are sufficient to teach the patient and/or caregiver these functional skills unless the patient is severely impaired or presents with another condition requiring additional treatment sessions. Those with progressive neurological diseases (ALS, MS, and Parkinson's) may need re-evaluation or modifications of the wheelchair management or propulsion of the wheelchair. Documentation must relate the training to expected functional goals that are reasonably attainable by the patient and caregiver.

- This code is used to show the skilled intervention that is provided related to the assessment, fitting and/or training for patients who must use a wheelchair for mobility.
- Use this code to train the patient, family, and/or caregiver in functional activities that promote safe wheelchair mobility and transfers. May also be for positioning to avoid pressure points.
- In some instances there may be a patient that is seen for a one time visit for a wheelchair assessment, which is only an assessment related to their wheelchair needs.

The therapist will bill 97542 with the units reflecting the time spent in the assessment.

- There may be circumstances where a patient may be seen for one time for a wheelchair assessment. If it is not necessary to complete a full patient evaluation, but only as assessment related to specific wheelchair needs, this one-time only session may be billed under 97542 with appropriate units reflecting time in the session. (Region B Future LCD: Outpatient Physical and Occupational Therapy services, page 49 of 101 printed 7-9-08. www.ngsmedicare.com).
- At some times an eval may be needed along with the wheelchair fitting and training.
- In this case the eval is billed and then only the time spent with 97542 should be billed for that assessment.
- Typically 3-4 visits should be sufficient to train the patient/caregiver.

TESTS AND MEASUREMENTS-

These codes require 1:1 patient contact as well as a separate written report.

97750 Physical Performance Test or Measurement, each 15 minutes- (Musculoskeletal, functional capacity) The provider performs a test of physical performance (BTE, Gait analysis, Tinetti, Berg) determining function or one or more body areas or measuring and aspect of physical performance, including functional capacity evals. This is usually beyond the usual eval service performed.

There must be written evidence documenting

- the problem requiring the test,
- the specific test performed and
- a measurement report which a description of the test performed,
- purpose for the test, outcome of the test,
- how the information obtained from the test impacts the plan of care.
- This code goes beyond the evaluation and a written report is required with this code.
- Examples of uses for this code include isokinetic testing, Functional Capacity Evaluation, and Tinetti (Smart Wheel Propulsion Analysis)
- It is not reasonable and necessary for the test to be performed and billed on a routine basis

This code cannot be used with another evaluation code. Must have a written report.

97755 Assistive Technology Assessment, each 15 minutes- (To restore, augment, or compensate for existing function, optimize functional tasks and/or maximize environmental accessibility)

- The provider performs an assessment for the possibilities and benefits of acquiring assistive technology device that will help restore, augment, or compensate for existing functional ability in the patient; or that will optimize functional tasks and/or maximize the patient's environmental accessibility and mobility.
- Coverage is specifically for assessment of mobility and seating systems that require high level optimize, not for routine seating and mobility systems.

This code cannot be used with another evaluation code. Must have a written report.

Proposed Evaluation Codes for 2017

The CMS proposed physician fee schedule for 2017 introduced the 3 new CPT codes for physical therapy evaluation and 1 new code for reevaluation. The new evaluation codes reflect 3 levels of patient presentation: low-complexity (97161), moderate-complexity (97162), and high-complexity (97163), and will replace the current 97001 code. The new reevaluation code replaces the current 97002.

**97165/97161 : Occupational therapy evaluation/
Physical Therapy, low complexity, requiring these
components:**

**97166/97162 :Occupational Therapy /Physical
Therapy evaluation, moderate complexity, requiring
these components**

**97167/97163; Occupational therapy /Physical
Therapy evaluation, high complexity, requiring these
components:**

**97168 Reevaluation of occupational therapy/physical
therapy established plan of care, requiring these
components:**

References:

1. Cook, A.M., Polgar, J.M. Cook and Hussy's Assistive Technologies Principles and Practice. (2008). Mosby
2. Cook, A.M., Polgar, J.M., Essentials of Assistive Technologies. (2012). Mosby.
3. Eggers, S., Myaskovsky, L., Burkitt, K., Tolerico, M., Switzer, G., Fine, M., et al. (2009). A preliminary model of wheelchair service delivery. Arch Phys Med Rehabil, 90, 1030.
4. [http://www.apta.org/PaymentReform/
NewEvalReevalCPTCodes/](http://www.apta.org/PaymentReform/NewEvalReevalCPTCodes/)
5. [http://www.aota.org/Advocacy-Policy/Federal-Reg-
Affairs/Coding/evaluation-cpt-codes-descriptors.aspx](http://www.aota.org/Advocacy-Policy/Federal-Reg-Affairs/Coding/evaluation-cpt-codes-descriptors.aspx)
6. [https://www.cms.gov/apps/physician-fee-schedule/
search/search-results.aspx?Y=0&T=4&HT=2&CT=0&H1=9
7001&H2=97999&M=5](https://www.cms.gov/apps/physician-fee-schedule/search/search-results.aspx?Y=0&T=4&HT=2&CT=0&H1=97001&H2=97999&M=5)

IC59: Integration of Powered Mobility, AAC, & Computers

Karen M. Kangas, OTR/L
Lisa Rotelli, AA of Science

Introduction:

Children are not small adults. This seems apparent, yet powered mobility systems have been developed for adults and their electronics and their integrative abilities have been created for adults. Consequently, how to use these systems with children must be altered, and understood to ensure that children can become independent in their use of the assistive technology they use.

In today's technological world "syncing" systems is recognized as a necessary and crucial component of efficient use of systems. The systems "synced" are primarily based on phone use, and its ability to access the internet. However, computer access is also crucial and parts of the smart phones and tablets we use, "sync" their usage with the computers we still need when completing all the work most adults manage throughout their days. For systems to work together "blue tooth" connectivity has become a favored relationship. Consequently, it is not surprising that in the powered mobility industry, the realization that the powered chair's joystick could also function as a "mouse" has been supported for many years. This "Blue Tooth" connectivity has also become favored.

However, when presuming that now a "blue tooth" mouse feature within a powered chair's expandable and programmable electronics is all a child needs, is, unfortunately, not accurately understood nor an adequate access for many children, especially those children who have complex bodies and who use Augmentative Communication Devices.

Understanding how things connect, and that they can connect in a blue tooth environment is not enough. All bluetooth connectivity is not equal. All connectivity is not equal. And, being able to manage mouse movements, must be able to be all mouse movements, which include a left click and in many application software, a right click as well.

Also, any child who uses scanning, whether single switch or dual switch scanning to manage an AAC device, cannot expect that bluetooth connectivity supports this usage.

Before blue tooth connectivity, an auxiliary or ECU (environmental control unit) was needed to connect to the controller of a powered chair, to allow a signal to be an output to be used for computer access or an AAC device. Currently, these interface boxes are often not considered necessary for "configurations" as the bluetooth connectivity is thought to be enough.

This could not be farther from the actual reality of how things work.

Some Facts Needed for Adequate Assessment: All expandable electronics are not equal.

In the USA today, we have primarily three platforms of powered chairs' electronics: R-net electronics (Permobil, and Quickie, and Rovi); Curtiss Electronics (Quantum Rehab's Qlogic, and Ottobock), and Mark 6 (Invacare). All of these systems are able to be programmed and to support alternative access to driving, access to powered seat functions, access to computers and access to Augmentative Communication Devices. They could also all manage other environmental controls, such as automatic door openers, garage door openers, and multiple other X10 technologies within a home.

How does a child tell her chair's controls that she doesn't want to drive right now, but she wants to tilt, or elevate, or use her computer or use her AAC device? This varies in each set of electronics. Some require managing a display and managing a menu, some required timed hits, some require the management of more than the joystick, and others require reading. All children are not yet able to read, or may be learning to read. How can we not provide them with independent control of access to all their systems?

All of these three platforms provide bluetooth connectivity. This ability for a joystick to be a mouse is a necessary tool for users of powered mobility to more readily be independent throughout their day to manage both their chairs and their other equipment. However, even when using a joystick a joystick on its own, is not a mouse, but rather only the travel of a mouse; the joystick has no part of it which is automatically a switch click, that has to "added." Yet a true mouse, not only travels across a screen, but also manages clicks, double clicks and click and drags. How all these mouse features are managed varies within each of the electronics' platform, and can be altered within these systems. (Just like we have Mac and PC platforms, and IOS and Android platforms)

Most frequent options are:

1. An alternative or specific way to manage the joystick, a "nudge" or a "quick or specific movement in a specific direction.
2. An additional switch added.
3. More than one additional switch added.

What is not obvious is how the user gets to the "mouse." And, then how the "user" manages the mouse's clicks. Frequently a user who has weakness cannot pick their hand off the joystick and hit a switch for a click and then place her hand back on the joystick easily. Many users don't have readily available another switch site to manage a mouse, or that switch site is not placed in a "motor-ready" and "efficient" placement. The beauty of a mouse, is that the hand does not have to leave the mouse to manage its travel and its clicking. But when a joystick is used as a mouse, managing the travel and the clicking is not as efficient nor easy.

Hence the first issue of the electronics which must be analyzed for each child user is:

- What must the child actually be able to manage to move from driving to mousing, from driving to managing seat functions, from driving to AAC management?
- To get to the “Mouse” usage, frequently a menu must be read, and managed to tell the chair that the mouse is ready to be used.
- If a child does not use a joystick this process becomes even more complicated, as the blue tooth connectivity is not able to be configured in separate switch modes. Mouse emulation is still needed.
- It must also be understood that mousing and clicking is not how most AAC devices work. Frequently a child can drive a powered chair and uses a scanning technique to manage the AAC device. Bluetooth connectivity does not provide access to scanning in a device.

Consequently, a child may be able to use some of the bluetooth connectivity for some access, but may still need mouse emulation to manage the AAC device.

If a child is using a dedicated AAC device (and let’s hope that is still supported as this is still the only way a child can access ALL of our language for novel speech, all other methods are simply APPS or derivations of spelling which can only work for some writing, or some lessened ability to access predetermined limited vocabulary), she will frequently use its software as the keyboard emulation or in short, for writing. This connectivity is critical. Using an AAC device is not just for “speaking” but also for “writing.” Spelling, even with word prediction, still takes longer than using the “language” of the AAC device as the “language” being written.

ALL Bluetooth Connectivity is not equal.

Children do not live in a single work environment or single home environment. They are in multiple classrooms, multiple settings, and need access in all those settings. They are also in various stages of LEARNING how to use their devices. Everyone knows that the “best” connectivity, meaning reliable “pairing” and “pairing staying paired” does not occur in multiple environments. It is very important that all environments are considered and “pairing” reliability is supported.

Hardware and Software Must be Analyzed; Their configurations changing as a child grows and develops.

When using technology with children, means children are learning now only HOW to use a piece of technology, they are also learning the software, too. They are learning to READ, and WRITE, they aren’t yet capable nor literate yet. Consequently, all the hardware a child will be using, laptops, desktops, phones, tablets, AAC devices, and Smartboards must be analyzed for their own connectivity, capabilities and “syncing” for use.

The software or application programs used within each of these pieces of hardware must also be used. Having bluetooth connectivity doesn’t help in many “apps” as they are still expected to be managed through direct selection. Even in the newest of IOS technology and its switch control, this switch control cannot be easily used in many apps. (Yes, some “recipes” can be developed for particular body movements to be “read” by the switch, but this still doesn’t work well in many children’s apps).

What is this analysis? It means that the adult teacher/therapist/RTS knows exactly how this hardware works, and what movements it takes to work, and how the menus are managed, and in the software, each piece of software is analyzed for all of the movements required to manage it.

Too frequently, when just having a mouse, to manage a program, the user has to keep going back to menu bar, and then returning to the actual point of activity, this constant back and forth management can be too hard for many children to manage, either physically or cognitively.

When the software and hardware have been analyzed, then they have to be assessed as to how fluent the child is with them. This means how has this been taught to a child, how is it managed while being taught to a child, and as the child learns, how can the child manage more and more it herself independently.

The irony of connectivity, is that if the powered chair is configured and programmed for all of it to be managed independently, it can NEVER be taught to a child who is not already a reader, and computer literate!!!

Also, ironically, this is how every system is shipped, in an adult mode, with all things configured.

Initially with a child, the configuration must be made to be extremely simple, obvious in its concrete function, and then altered as the child grows in experience. This is not only a programming skill, it also requires competence in mounting, switch use and software and hardware fluency.

Summary

Children are not small adults. All children learn and grow, switch sites develop, and powered mobility must be able to “grow” in its connectivity as well. Programming is key, and must be able to be managed by the family and current adults within each child’s environment, and not “held hostage” by a rehab supplier.

Bluetooth mousing is not enough. It is still important that an auxiliary interface box be available for children. Many will need mouse emulation, and also need to be able to manage scanning within their AAC and computer use, which is not available through a blue tooth mouse.

How a mouse clicks and how the child will manage the clicks is critical to assessment of how the chair’s electronics need to be programmed, and in fact, which chair’s electronics platform adequately suits the child’s activity.

Joystick management does not preclude nor presume that a child can use her joystick as a mouse.

Assessment of a powered chair for a child, especially a child with a complex body, must include an analysis of the powered chair's electronic's platform, and how that platform "manages" using its access to also manage powered seat functions, access to a computer, access to an AAC device, independently. How can this be "broken" down for teaching, with a younger child or an inexperienced child, and then how can it be configured as the child grows in experience and fluency.

References:

We are sharing our original work in this session. However, instead of actual references, interested reading should include:

1. P.Nisbet, CALL Centre, Univ of Edinburgh, Med. Eng. Phys. Vol 1, No,3, pp. 193-202, 1996; "Integrating Assistive Technologies: Current Practices and Future Possibilities"
2. Mittler, J. 2007, Technology and Media Division (TAM), Assistive Technology and IDEA, Regulations; tamcec.org/pdf/AssistiveTech and IDEA Regs.pdf
3. Romich, Hobson, LoPresti, Spaeth, Creech, "Integration of Electronic External Devices for Powered Mobility Systems, RERC-I, Final report, 1993-8
4. Dugan, Millborne, Campbell, Wilcox, 2004, Research Brief, Vol 1, Number 5, "Evidence Based Practice in Assistive Technology" Tots'n Tech Research Institute

Authors

Karen M. Kangas OTR/L

Seating, Mobility and Positioning Specialist, Assistive Technology Specialist, Adjunct University Faculty, Clinical Educator, Consultant
1 Beaver Road, Camp Hill, PA 17011; Email: kmkangas@ptd.net

Lisa Rotelli

Director, Education Consultant/Coordinator,
Developer and Creator of Products
Adaptive Switch Labs, Inc. 125 Spur 191, Suite C,
Spicewood,TX 78669;
1-800-626-8698; Email: lrotelli@asl-inc.com

IC60: Ideas to Innovation: Student Design Projects and Capstone Projects

Mark P. Warner, PT, ATP

Carmen P Digiovine, PhD, ATP/SMS, RET

Mary Goldberg, PhD

Sandra Anstaett Metzler, D. Sc., P.E.

Innovation is a critical component to all academic programs, especially given the need for relevant problems for engineering capstone programs and doctorate-level clinical programs. The problem is that there are more students interested in getting practical experience in the design process than there are identified real-world problems. Alternatively, individuals with disabilities, their families and the clinicians that work with these individuals have a plethora of problems for the students to address. The purpose of this workshop is to provide an overview of capstone design programs, and provide information to non-academic clinicians and suppliers on how they can leverage their real-world experience to train the next generation of engineers and clinicians, while developing prototype designs that can improve the quality of life of individuals with disabilities. The authors will provide case studies from the University of Pittsburgh and The Ohio State University, identifying the opportunities, pitfalls and overall realities of working with an academic program with a perspective from a therapist/mentor of a recent Capstone Project.

References

1. Hanumara, N. C., Begg, N. D., Walsh, C. J., Custer, D., Gupta, R., Osborn, L. R. & Slocum, A. H. (2013). Classroom to Clinic: Merging Education and Research to Efficiently Prototype Medical Devices. *IEEE Journal of Translational Engineering in Health and Medicine*.
2. Howard, T., Culley, S. & Dekoninck, E. (2008). Describing the Creative Design Process by the Integration of Engineering Design and Cognitive Psychology Literature Design Studies.
3. McClelland, M. & Kleinke, D. (2013). Improving Lives Using Multidisciplinary Education: Partnering to Benefit Community, Innovation, Health, and Technology. *Journal of Nursing Education*.

IC61: Comparative Effectiveness Research: A Conceptual Model in Wheelchair Service Provision

Deepan Kamaraj, MD
Nathan Bray, PhD

With increasing awareness regarding Evidence-based practices, along with the introduction of policies and laws at the institutional and national levels that necessitates stringent record of interventions and their outcomes; the need for studies that evaluate effectiveness is on the rise. This increasing need has led to the new branch of science called the Comparative Effectiveness Research (CER). The Affordable Care Act defined CER as “research evaluating and comparing health outcomes and the clinical effectiveness, risks, and benefits of 2 or more health care interventions, protocols for treatment, care management, and delivery and any other strategies or items being used in the treatment, management, and diagnosis of, or prevention of illness or injury in, individuals.”(Hartling, Vandermeer, & Fernandes, 2014) The primary purpose of CER is to assist various stakeholders of the health care delivery process in making informed decisions by advancing the quality and relevance of evidence available(Krishnan, Schatz, & Apter, 2011).

This instructional course will discuss literature explaining Comparative Effectiveness Research within the realm of Assistive Technology, and present a conceptual framework that would be applicable for the various stakeholders of the wheelchair service provision (RESNA, 2011). The goal of this session is to present and discuss useful outcome measures that could be employed by clinicians and other stake holders to evaluate effectiveness during the process of wheelchair service provision.

Learning Objectives:

Upon completion of this session, attendees will be able to;

- Compare and contrast efficacy vs. effectiveness research studies.
- Define and describe comparative effectiveness research, and its applications within the realm of wheelchair service provision.
- List at least two different outcome measures that could be applicable in clinical practice to evaluate wheelchair service provision.

References:

1. Hartling, L., Vandermeer, B., & Fernandes, R.M. (2014). Systematic reviews, overviews of reviews and comparative effectiveness reviews: a discussion of approaches to knowledge synthesis. *Evidence-based child health. A Cochrane review journal.* 9(2), 486-94.
2. Krishnan, J.A., Schatz, M., & Apter, A.J. (2011). A call for action: Comparative effectiveness research in asthma. *The Journal of allergy and clinical immunology.* 127(1), 123-7.
3. RESNA Wheelchair Service Provision Guide (2011). Retrieved online from www.resna.org/knowledge-center/position-papers-and-provision-guides.

IC62: Evaluation of Saddle Seating for Children with Special Needs

Sharon L. Sutherland (Pratt), PT

Seating challenges in children with movement disorders requires individual adjustment, careful choice of device, trial and adaptation to the child's needs. When we see children sitting in a position with limited possibility to control the trunk, head and upper extremities it is important that we act.

Some important questions that will be discussed are for example:

- How often do we get referrals to seating clinic for clients presenting with severe scoliosis, pelvic obliquity and pelvic rotation?
- How much do the hips influence our client's seated postural alignment?
- Is there ever a close relationship between the hip ranges of motion relative to seating and the degree of postural deviation observed?
- When we observe the client in their seated position and pay attention to the lower rib cage and the ASIS alignment for example, does this relationship change when the client is in supine? (This, in my clinical experience is a very important observation)
- How do we translate the clinical findings into optimal solutions?

In my professional journey over the past 5 years, I have had the privilege of doing hands on assessments with over 500 clients who presented with complex postural and skin integrity needs relative to sitting. The direct relationship between hip joint/pelvic ranges of motion limitations relative to sitting and consequential pelvic – trunk misalignment has truly opened my eyes. I firmly believe that in the absence of respecting the hips, many children are presenting in their more traditional type seating with compromised postures leading to respiratory and gastro-intestinal complications.

Saddle seating when available is an excellent alternative type seating that can help us to “take the work out of sitting” for some of these children.

In the experience of some of the authors the Posture and Postural Ability Scale (PPAS) is useful for comparing seating postures created by different seating solutions. During this presentation we will show case studies where the PPAS is used to compare traditional seating and saddle seating for example.

Various client cases will be used to analyze the relationship between hip limitations and seated postural presentations. We will review some possible generic options for each client and discuss in detail the potential negative and positive consequences/outcomes for each.

Reading resources:

1. Rodby-Bousquet, E, Persson- Bunke M and Czuba T: Clinical Rehabilitation 1-8 “Psychometric evaluation of the Posture and Postural Ability Scale for children with Cerebral Palsy”.
2. History of the PPAS: Posture and Postural Ability Scale
 - 1970 The Physical Ability Scale (Noreen Hare)
 - 1980 The Chailey Levels of Ability (Putney et al)
 - 1990 Posture Ability Scale (Pauline Pope)
 - 2010 Posture and Postural Ability Scale (Pope et al)
3. What Happens When You Spend A Lot Of Time Sitting? : Reference: FITDAY: <http://www.fitday.com/fitness-articles>

IC63: Running a Seating Clinic 102: Going Beyond the Basics

Lauren Rosen, PT, MPT, MSMS, ATP/SMS
Jeff Brown

Abstract:

Should the concept of a traditional seating clinic be the exception or the rule within our industry? With increasing cuts in funding and increased productivity demands on therapists, can seating clinics survive? Successful seating clinics exist in many different environments servicing clients of different ages and diagnoses. To be successful, there must be agreement between the therapists and suppliers about the importance of this provision method. Additionally, to have a successful seating clinic all parties working in the clinic must be educated in funding, proper documentation, and have appropriate relationships with manufacturers' representatives.

This presentation will give insight to the various types of seating clinics and how to make them successful. The presenters will include an experienced team including a seating therapist, a supplier, and a manufacturers' representative.

All aspects of a successful clinic will be discussed. These include: The appropriate length of time for an equipment evaluation. The importance of equipment delivery at the clinic where it was prescribed. The CPT codes that can be billed for successful payment of services for the clinic. The minimal amount mobility equipment does a clinic need to have on site for successful evaluation. The members of the service team need to be present for Evaluation/Delivery.

Case studies and examples will be used to show how a well-run clinic functions and the problems that can occur with other provision methods.

Objectives:

- List three reasons that therapists, suppliers, and manufacturer's representatives are necessary for a successful seating clinic.
- List three strategies to properly document evaluations in a timely manner.
- List four of the CPT codes used for wheelchair evaluations and delivery.

References:

1. Arledge, S., Armstrong, W., Babinec, M., Dicianno, B., Digiovine, C., Dyson-Hudson, T., Pederson J., Piriano, J., Plummer, T., Rosen, L., Schmeler, M., Shea, M., Stogner, J. The RESNA Wheelchair Service Provision Guide. Approved January 26, 2011.
2. Casey, K. (2011). Creating an assistive technology clinic: The experience of the Johns Hopkins AT Clinic for patients with ALS. *Neurorehabilitation*, vol. 28, no. 3, pp. 281-293.
3. Toro et al (2012) Quantitative Exploratory Evaluation of the Frequency, Causes and Consequences of Rehabilitation Wheelchair Breakdowns Delivered at a Pediatric Clinic in Mexico

IC64: Colombian Wheelchair Sector: People, Policy, Products, and Provision

Maria Luisa Toro, PhD

Sara Munera, PT

Jonathan Pearlman, PhD

Background

Approximately 15% of the world's population has a disability and 1% needs a wheelchair (World Health Organization 2011; World Health Organization 2008), this prevalence is higher for developing countries and it will keep increasing in upcoming years due to the aging of the world's population (Lee 2003). Access to appropriate wheelchairs is a right for people with disabilities according to the United Nations Convention on the Rights of Persons with Disabilities (UNCRPD) (United Nations 2006). Unfortunately, it is estimated that in developing nations only 15% of those who need a wheelchair have one (World Health Organization 2011). Additionally, discrimination against people with disabilities as well as a lack of education about this issue are significant barriers to the human right of personal mobility (World Health Organization 2008).

There are personal and social consequences of not having an appropriate wheelchair or receiving it without the related services. Health related issues can develop, such as pressure sores and body shape distortions; this can decrease independence, self-esteem, and confidence impacting the wheelchair user's life (World Health Organization 2012). There is also a link between disability and poverty (World Health Organization 2011). Children with disabilities are less likely to go to school (The World Bank 2015) and adults with disabilities are more likely to be unemployed and generally have lower wages when compared to the general population (World Health Organization 2011).

In developing countries particularly, there is a lack of accurate information on the number of people with disabilities, need for a wheelchair, local production or importation, etc. This data is needed to inform policy makers on improving access to appropriate assistive technology devices.

The International Society of Wheelchair Professionals, since its creation in 2014, has been playing an important role worldwide supporting stakeholders in developing countries to gather the information that is needed to successfully advocate for the fulfillment of the right to personal mobility. This paper summarizes a desk review of the current state of the wheelchair sector in Colombia looking at the country's population, policies, products, and provision services.

People

Colombia has a population of 48.94 million according to the census bureau (Departamento Administrativo Nacional de

Estadística (DANE) 2016). The latest population census is from 2005 and reported that 6.3% of the population was people with disabilities (DANE, 2005). The Ministry of Health has a disability registry that aims to gather the prevalence and needs of the Colombians with disabilities. However, this registry has only been able to measure to about 1 million people with disabilities (Ministerio de Salud y Protección Social, 2016). Wide social injustice persists for people with disabilities in Colombia, including lack of access to quality health services (Instituto Nacional de Salud, 2015). Only about 11% of those in the registry report being able to access habilitation or rehabilitation services despite the fact that more than 70% report having health coverage (Agudelo & Seijas, 2012). A study by the regional government of Antioquia reported that less than 10% of people with disabilities had access to rehabilitation services but identified access to education, built-environment accessibility, and labor inclusion as their priorities (Gobernación de Antioquia, 2014). There is no information about how many people are in need of a wheelchair and how many have access to one.

In contrast to Colombia's data and according to WHO estimates, there are about 500,000 people who need a wheelchair. Additionally, this country is expected to have a high prevalence of people requiring a wheelchair since it has the longest civil war in the Americas (Handicap International 2013), a rapidly aging population, high prevalence of road traffic accidents and poverty.

Policies

In 2011, Colombia ratified the UNCRPD (República de Colombia 2009; República de Colombia 2013a; Human Rights Watch 2011) and created a National Disability System and public policy regarding disability to adopt the legislations and administrative modifications needed to accomplish the goals of this Convention.

Access to appropriate wheelchairs and related services are human rights as stated in the Convention in articles 20 and 26; but, wheelchairs are excluded from the national health care plan (República de Colombia 2013b). Since not having access to a wheelchair is considered a violation of the right to health under the Colombian law, there is a legal mechanism via a court appeal where people can have access to the prescribed wheelchair paid by the government.

For citizens in the lowest income bracket, in some municipalities there are subsidies through the government to receive a wheelchair once a year, this wheelchair is not always delivered with appropriate services such as user and environment evaluation, wheelchair set up, etc. Due to this subsidies some people may have more than one wheelchair, likely an inappropriate one, while many are still waiting for one.

The military have a special social security system which implemented assistive technology provision guidelines in November 2015. In this document an assistive technology device must be prescribed by an interdisciplinary rehabilitation team, the prescription is written by a medical doctor and must take into consideration the contextual factors of the user. Users that have received wheelchairs

should be followed up. During the follow up appointment the rehabilitation team must check that the product was delivered by the vendor according to the prescription of the doctor, and that the user received training on how to use and maintain the wheelchair. Additionally, the vendor must provide maintenance once a year. There should be three follow up times: a year after the delivery, 3 and 5 years later (Ministerio de defensa nacional. Comando general de las fuerzas militares Dirección general de sanidad militar. 2015).

According to these guidelines, wheelchairs are divided in 3 types: basic, medium range and high-technology. Devices in the first two categories can be prescribed every 3 years, and those in the high-tech group every 5 years. When a new device is prescribed, the old device needs to be returned to the system. For power wheelchairs, the system will cover the replacement of the batteries only once, if batteries need to be replaced again, the user should assume the cost. High-tech wheelchairs must have a 5-year warranty period, after the product warranty period ends, the user must assume maintenance and repairs costs. In order for the military system to accept assistive technology donations, the products must have a local vendor able to provide maintenance and repairs services. The military social security system would have a uniform assistive technology database that will collect the user and device information (Ministerio de defensa nacional. Comando general de las fuerzas militares Dirección general de sanidad militar. 2015).

After the ratification of the UNCRPD, the Colombian government presented the first report to the UN in 2013 (Republica de Colombia 2013), and stated related to article 20—access to personal mobility and specifically to wheelchairs that local government entities will be supported by the Ministry of Health to strengthen the delivery of assistive technology and are in the process of developing the guidelines for the implementation of the assistive technology banks. And that the national regulatory commission would unify the health care regimes and will include access to assistive technology that would contribute to mobility of people with disabilities.

In addition, this report mentions assistive technology under two other different articles. In article 25 –access to health—it reports that the new health law of 2013 will warrantee the delivery of assistive technology in the framework of the social security system. In article 26 –habilitation/rehabilitation—the Ministry of Health will confer funding to the municipalities for assistive technology that are excluded from the health care plan. Under article 28 –social wellbeing and protection—the National Agency for Poverty Alleviation is measuring the achievements of the community based rehabilitation programs and access to assistive technology. It is important to note that even though this is what the government reported as their current plan of action, as of November 2016, wheelchairs continue to be explicitly excluded from the healthcare plan.

In the shadow report that the Colombian coalition of people with disabilities presented to the United Nations in Geneva (Coalicion Colombiana para la implementation de la Convencion de los derechos de las personas con discapacidad 2016), there was no mention of article 20 and the challenges that people face in accessing assistive technology. The only mention of poor access to wheelchairs is specifically related to people with disabilities in jail.

Related to article 26, the report states that there are no clear pathways to access rehabilitation services and these are scarce in rural areas. Therefore, poor people with disabilities living in rural areas face multiple challenges to access the services they need.

In response to the Colombian government and the shadow report, the UN recommends that the government expand the habilitation and rehabilitation services to comply with the UNCRPD. The UN emphasizes on the inclusion and access to services of people with disabilities victims of the internal conflict (Naciones Unidas 2016).

Products

In Colombia, in recent years, there has been an influx of high-cost and high-end imported wheelchairs and cushions. For users with payment capacity or via a legal appeal, there is access to a wide range of wheeled-mobility devices, from hospital-style wheelchairs to power wheelchairs with all powered seat functions and alternative controls. However, for those with limited payment or legal appeal capacity, the options are not as wide. There are also organizations that make massive donations of products both in the cities and rural areas.

Despite the multiple wheelchairs available, there is a lack of appropriate wheelchairs for people living in rural areas with rough terrains. Currently, there is no quality regulation in place. Specifically, the Colombian standards agency ICONTEC has not adopted the ISO 7176 standard section 8, which relates to wheelchair durability. Only the sections related to measurements are adapted to the context.

Products are resold internally several times, which inflates the costs even more. For example, a vendor is the representative of an imported brand who sells the product to pharmacies, who then sell it at a higher price. Since there are no regulations in terms of product classification, how often a new wheelchair should be prescribed, or caps for type of products, then you can find the same “type” of product with a wide variety of prices depending on whether it is imported or nationally fabricated. For example: an aluminum ultra-light wheelchair nationally made can cost around \$ 900 USD while an imported aluminum ultra-light wheelchair costs \$3000 USD. While the vendor of the imported product would argue that the quality is better, without enforcing ISO standards, there is no objective manner to measure this. In the meantime, our public system continues to pay for the wheelchairs that are prescribed and fought through the legal system regardless the source of the product.

Provision

Since wheelchairs are not covered through the health care plan, there is a lack of nation-wide guidelines for the services, with some users not having a wheelchair at all, some receiving wheelchairs “off the shelf”, and many not receiving training on how to use the wheelchair nor maintenance and repairs services. There is a need to advocate for the regulation of the wheelchair sector in the country to warrantee equal access to appropriate wheelchair products and services to the users that need them.

Some health insurance companies require that a physiatrist

prescribes the wheeled mobility device, but in many cases only a prescription written by a medical doctor suffices to appeal for access to a wheelchair. In the end, the judge is the one that grants access to the devices. There is an important need to educate wheelchair users, medical doctors, physical therapists, occupational therapists, biomedical engineers, social workers, and community based rehabilitation workers on what an appropriate wheelchair is and how it should be provided.

Specific to professional training, the International Committee of the Red Cross in Colombia is holding training seminars related to appropriate wheelchair provision in collaboration with the Colombian School of Rehabilitation (Comité Internacional de la Cruz Roja 2016). Their goal is to train 50 rehabilitation professionals in 2016. Additionally, manufacturers are offering informal trainings and webinars based on products, without a standardized curricula or evaluation method.

Proposed strategy

Due to the lack of accurate data related to the need of wheelchairs in Colombia, there are no policies in place to promote access to assistive technologies, even though, in paper, the country recognized the importance of these devices for social participation and full enjoyment of all human rights.

Despite the fact that products are available, without regulations in terms of quality standards, prices, and provision, it is difficult to access appropriate products and services such as training on how to use them, and how to perform maintenance and repairs. In addition, the lack of awareness on the relevance of assistive technologies and the lack of trained professionals in wheelchairs delivery makes it even harder to access these products.

There is a need to gather a critical mass that advocates and implements the solutions to the above-mentioned needs. Articulation of stakeholders to add efforts in modifying Colombian wheelchair sector is needed.

These efforts would be more effective if national stakeholders count with the technical assistance of international organizations such as ISWP and WHO. Learning from other countries efforts and sharing experiences can facilitate change in the wheelchair sector.

References

1. Coalición Colombiana para la implementación de la Convención de los derechos de las personas con discapacidad, 2016. Informe alternativo de la coalición Colombiana para la implementación de la Convención sobre los derechos de las personas con discapacidad, Ginebra, Suiza.
2. Comité Internacional de la Cruz Roja, 2016. La discapacidad está en el entorno, no en mí: usuaria de silla de ruedas en Colombia | Comité Internacional de la Cruz Roja. Available at: <https://www.icrc.org/es/document/discapacidad-colombia-silla-de-ruedas-violencia-bala-perdida-medellin?language=en>.
3. Departamento Administrativo Nacional de Estadística (DANE), 2016. La población proyectada de Colombia. Available at: <http://www.dane.gov.co/reloj/>.
4. Handicap International, 2013. Colombia. Available at: <http://www.handicap-international.us/colombia> [Accessed March 6, 2016].
5. Human Rights Watch, 2011. Colombia is 100th country to ratify disability rights treaty. Available at: <https://www.hrw.org/news/2011/05/16/colombia-100th-country-ratify-disability-rights-treaty> [Accessed March 6, 2016].
6. Lee, R., 2003. The demographic transition: Three centuries of fundamental change. *Journal of Economic Perspectives*, 14(4), pp.167–190. Available at: http://www.economie.ens.fr/IMG/pdf/lee_2003.pdf [Accessed March 1, 2016].
7. Ministerio de defensa nacional. Comando general de las fuerzas militares Dirección general de sanidad militar., 2015. Protocolo administrativo para la prescripción, seguimiento y control de los productos de apoyo en salud (PAS) para el SSFM DGSM,
8. Naciones Unidas, 2016. Comité sobre los Derechos de las Personas con Discapacidad: Observaciones finales sobre el informe inicial de Colombia,
9. Republica de Colombia, 2013. Informe inicial sobre la implementación de la Convención sobre los Derechos de las PcD en Colombia, Bogotá.
10. República de Colombia, 2009. Ley 1346, Available at: <http://www.alcaldiabogota.gov.co/sisjur/normas/Norma1.jsp?i=37150> [Accessed March 6, 2016].
11. República de Colombia, 2013a. Ley 1618, Available at: <http://www.alcaldiabogota.gov.co/sisjur/normas/Norma1.jsp?i=52081#0> [Accessed March 6, 2016].
12. República de Colombia, 2013b. Resolución 5521, Available at: <https://www.minsalud.gov.co/sites/rid/Lists/BibliotecaDigital/RIDE/DE/DIJ/resolucion-5521-de-2013.pdf> [Accessed March 6, 2016].
13. The World Bank, 2015. Disability Overview. Available at: <http://www.worldbank.org/en/topic/disability/overview#1> [Accessed March 1, 2016].
14. United Nations, 2006. Convention on the rights of persons with disabilities and optional protocol, New York, NY: United Nations. Available at: <http://www.un.org/disabilities/convention/conventionfull.shtml> [Accessed September 29, 2015].
15. World Health Organization, 2008. Guidelines on the provision of manual wheelchairs in less-resourced settings, Switzerland.
16. World Health Organization, 2012. Wheelchair Service Training Package. Reference Manual for Participants. Basic Level., Available at: http://apps.who.int/iris/bitstream/10665/78236/1/9789241503471_reference_manual_eng.pdf?ua=1 [Accessed March 1, 2016].
17. World Health Organization, 2011. World report on disability, Matla.

PS8.1: System Requirements for Continuous Seat Pressure Mapping

Tamara Vos-Draper, OT, ATP, SMS

Background:

At any given time, approximately 25% of the 300,000 people with spinal cord injuries (SCI) in the United States will have a pressure ulcer related to sitting[1-4]. Total yearly treatment costs are estimated at a staggering \$6.3 billion.[5] With ulcer recurrence rates as high as 79%[6-8] and mortality rates as high as 48% when sepsis is present,[3, 9, 10] there exists a critical clinical need to target prevention of ulcer development to avert serious complications and death. A key component for the prevention of seating-related pressure ulcer development is education to minimize pressure under the sacral, ischial and sacrococcygeal areas.[9, 11-13] Even with careful adherence to skin health recommendations and patient education, pressure ulcers still occur from seat cushion failures, inadequate equipment, and poor positioning strategies[14, 15].

Seat interface pressure mapping technologies, commonly used in the clinical setting for the past 3 decades, are able to detect hazards in pressure distribution[16-20]. What is needed, however, is a system that provides a comprehensive view of a wheelchair user's seated pressures and skin protection behaviors during the time between clinical visits. To realize this, two things are critical: 1) having a robust sensor that operates accurately and repeatably for long periods of time, and 2) design of a feedback system that elicits the behavior changes necessary for pressure ulcer prevention. Recent technological advances have reduced the hardware requirements and costs sufficient to enable this type of pressure mapping to extend into the home environment[21-26].

Our prototype system demonstrated the safety and feasibility of daily field use by wheelchair users with spinal cord injury, but sensor performance under daily, continuous loading is still undefined. The objective of this paper presentation is to report the results of experiments that tested long-term and field-based system performance by (a) characterizing the accuracy of pressure measurement in regards to the drift behavior of the pressure mat, and (b) determining if pressure distribution measurements are repeatable during daily use over a month long period.

Methods

Our goal was to test the system performance both long-term and in the field by (a) characterizing the accuracy of the dispersion index (DI) measurement in regards to the drift behavior of the pressure mat, and (b) determining if the DI measures of seating pressure distribution from our wireless seat interface pressure system are repeatable during daily use over a month long period.

Dispersion Index (DI)

The DI measure was used as the main outcome measure to test the system performance against. Previous investigations have determined safe levels of seating pressure distribution[27-29] in 4 areas (Fig 3): (1) ischial well [$<55\%$], (2) left ischial tuberosity [$<35\%$], (3) right ischial tuberosity [$<35\%$], and the (4) sacrococcygeal area [$<15\%$]. The DI for each of the areas is defined as the pressure within the specified area divided by the total pressure applied to the pressure mat. Because of its clinical utility to aid in positioning and previous repeatability[29], we integrated the calculation of these measures within our web-based application. Our preliminary data demonstrated the long-term stability of the DI measure.

Long-Term Accuracy

To quantify and characterize factors affecting sensor accuracy (drift and calibration), a series of bench tests were completed to test how DI measurements from objects of known weight and dimension change over time. To test the necessary calibration requirements, 2 FSA pressure mats (Vista Medical) were calibrated for each frequency: monthly and quarterly (every 3 months). Pressure mats were calibrated with the pressure chamber according to manufacturer recommendations.

Sensor drift of DI measures were studied under two conditions: (1) continuous daily loading (8am-5pm) with offloading overnight and (2) loading according to current clinical recommendations for seating pressure offloading (2 minutes of offloading every 30 minutes between 8am and 5pm) with offloading overnight. The pressure mats from each calibration frequency group were studied under each condition. For all testing, the pressure mats were placed atop Stimulite® Supracor wheelchair cushions. Loading was applied to each mat using three cylindrical weights of known mass and dimension to mimic loading concentrations during sitting. Data collection for Condition 1 occurred during one week per month over the 3-month period and involved automated pressure mappings every hour. Data collection for Condition 2 occurred once per month and involved automated pressure mappings every 30 minutes, before and after the 2-minute offloading period. The DI measures were determined and compared with the known DI (from weights of known dimension) to determine accuracy and drift.

Field-Based Repeatability

To quantify long-term, field-based repeatability, 5 able-bodied participants use the pressure mapping system for 1 month. Participants all had desk jobs and used the same office chair for the full testing period. Participants' smartphones were

equipped with the pressure-mapping app and the pressure mat was installed on their desk chair by study staff to ensure proper and secure placement. Participants were instructed to take recordings each day after initially sitting in the chair for a total of 20 workdays. Additionally, once a week (on the same day each week), subjects took 8 measurements during the day at least 30 minutes apart and always immediately following 2-minutes of standing. Participants received electronic reminders to perform their 8 measurements on their chosen day. Recorded maps were automatically uploaded into the secure Mayo Clinic server and data will be checked weekly.

Findings

Long-Term Accuracy

Bench-top testing results were evaluated with-in day and across days.

Across the 3-month testing period, the monthly-calibrated mats had an average error of 0.17% between the known DI and the DI as measured by the mats. The quarterly calibrated mat had an average error of 0.46%. When comparing the two calibration methods (monthly and quarterly), the difference was not statistically significant (ANOVA, p-value=0.056). The monthly-calibrated mat measured at 2% difference in the DI between month 1 and month 3. The quarterly calibrated performed with a 6% difference in the DI between month 1 and month 3. The difference between the two calibration types was not statistically significant (ANOVA, P-value=0.285). The monthly-calibrated mat had a within-day drift rate for the DI measure of 1% per hour. The quarterly calibrated mat had a within-day drift rate for the DI measure of 1.2% per hour. Across all three months, the monthly-calibrated mat had a drift rate for the DI measure of 4.6% per month, and the quarterly calibrated mat had a drift rate for the DI measure of 6.6% per month.

Field-Based Repeatability

5 able-bodied participants successfully completed the one-month testing period. The analysis of this data is ongoing. Preliminary results show a within-day coefficient of variation of less than 1% and a between-day coefficient of variation across the month long testing period of 16%.

Conclusion

The goal of this sub-study of a larger project was to characterize the performance of our pressure mapping system in regards to accuracy and repeatability of the dispersion index measure of pressure distribution. The ultimate goal in terms of using a pressure mat is to use the same mapping system over time under the same person. Therefore, our interest is really in how much variation there is in the pressure readings across time on the same mat when the mat is calibrated regularly versus not calibrated regularly. Our ultimate questions are whether we can continue to obtain sufficiently accurate and repeatable data with quarterly calibrations instead of monthly calibrations for field-based testing to reduce burden on participants who would need to bring the mats back monthly for recalibration. Based on our bench testing to determine the calibration needs of the mapping system for use in the field, quarterly calibration is adequate and does not significantly affect accuracy for

dispersion index measures. More extensive periods of study would be necessary to determine if calibration can be extended beyond quarterly.

The measurement of dispersion index is dependent on repeatable positioning of the person on the mat. Crude measures can be made based on mat regions or more individualized and clinically-meaningful measures can be made based on the individual's bony anatomy. The protocol, system, and analysis methodology is continuing to be optimized to provide the most relevant and meaningful data to the person.

Ongoing and future aspects of this study include testing of the system in adults with spinal cord injury to determine if the compensatory feedback of the mobile pressure mapping system can induce increased movement behavior. At the conclusion of the full study, we aim to have robust guidelines determined for a mobile pressure mapping system and to have demonstrated if access to the system increases body movement.

References

1. Krause, J.S., Skin sores after spinal cord injury: relationship to life adjustment. *Spinal Cord*, 1998. 36(1): p. 51-6.
2. Raghavan, P., et al., Prevalence of pressure sores in a community sample of spinal injury patients. *Clinical Rehabilitation*, 2003. 17(8): p. 879-84.
3. Center, N.S.C.I.S., 2012 Annual Statistical Report for the Spinal Cord Injury Model Systems – Complete Public Version, U.o.A.a. Birmingham, Editor.: Birmingham, Alabama.
4. Fuhrer, M.J., et al., Pressure ulcers in community-resident persons with spinal cord injury: prevalence and risk factors. *Archives of Physical Medicine & Rehabilitation*, 1993. 74(11): p. 1172-7.
5. Akins, J.S., P.E. Karg, and D.M. Brienza, Interface shear and pressure characteristics of wheelchair seat cushions. *Journal of Rehabilitation Research & Development*, 2011. 48(3): p. 225-34.
6. Bates-Jensen, B.M., et al., Characteristics of recurrent pressure ulcers in veterans with spinal cord injury. *Journal of Spinal Cord Medicine*, 2009. 32(1): p. 34-42.
7. Mawson, A.R., et al., Risk factors for early occurring pressure ulcers following spinal cord injury. *American Journal of Physical Medicine & Rehabilitation*, 1988. 67(3): p. 123-7.
8. Niazi, Z.B., et al., Recurrence of initial pressure ulcer in persons with spinal cord injuries. *Advances in Wound Care*, 1997. 10(3): p. 38-42.
9. Staas, W.E., Jr. and H.M. Cioschi, Pressure sores--a multifaceted approach to prevention and treatment. *Western Journal of Medicine*, 1991. 154(5): p. 539-44.
10. Thomas, D.R., Prevention and treatment of pressure ulcers: what works? what doesn't? *Cleveland Clinic Journal of Medicine*, 2001. 68(8): p. 704-7.
11. Thietje, R., et al., How does knowledge about spinal cord injury-related complications develop in subjects with spinal cord injury? A descriptive analysis in 214 patients. *Spinal Cord*, 2011. 49(1): p. 43-8.
12. Verschueren, J.H.M., et al., Occurrence and predictors of pressure ulcers during primary in-patient spinal cord injury rehabilitation. *Spinal Cord*, 2011. 49(1): p. 106-12.
13. Consortium for Spinal Cord Medicine Clinical Practice, G., Pressure ulcer prevention and treatment following spinal cord injury: a clinical practice guideline for health-care professionals. *Journal of Spinal Cord Medicine*, 2001. 24 Suppl 1: p. S40-101.
14. Clark, F.A., et al., Data-based models of how pressure ulcers develop in daily-living contexts of adults with spinal cord injury. *Arch Phys Med Rehabil*, 2006. 87(11): p. 1516-25.
15. Dunn, C.A., et al., Response factors surrounding progression of pressure ulcers in community-residing adults with spinal cord injury. *American Journal of Occupational Therapy*, 2009. 63(3): p. 301-9.
16. Stinson, M.D., A.P. Porter-Armstrong, and P.A. Eakin, Pressure mapping systems: Reliability of pressure map interpretation. *Clinical Rehabilitation*, 2003. 17: p. 504-511.
17. Crawford, S.A., et al., An investigation of the impact of the Force Sensing Array pressure mapping system on the clinical judgement of occupational therapists. *Clinical Rehabilitation*, 2005. 19(2): p. 224-31.
18. Norman, D., Measuring interface pressure: validity and reliability problems. *Journal of Wound Care*, 2004. 13(2): p. 78-80.
19. Sprigle, S. and S. Sonenblum, Assessing evidence supporting redistribution of pressure for pressure ulcer prevention: a review. *J Rehabil Res Dev*, 2011. 48(3): p. 203-13.
20. Brienza, D.M., et al., The relationship between pressure ulcer incidence and buttock-seat cushion interface pressure in at-risk elderly wheelchair users. *Arch Phys Med Rehabil*, 2001. 82(4): p. 529-33.
21. Stinson, M., A. Porter, and P. Eakin, Measuring interface pressure: A laboratory-based investigation into the effects of repositioning and sitting. *American Journal of Occupational Therapy*, 2002. 56: p. 185-190.
22. Barnett, R.I. and F.E.t. Shelton, Measurement of support surface efficacy: pressure. *Adv Wound Care*, 1997. 10(7): p. 21-9.
23. Bogie, K., et al., New technique for real-time interface pressure analysis: getting more out of large image data sets. *J Rehabil Res Dev*, 2008. 45(4): p. 523-35, 10 p following 535.
24. Crawford, S.A., et al., Impact of sitting time on seat-interface pressure and on pressure mapping with multiple sclerosis patients. *Archives of Physical Medicine & Rehabilitation*, 2005. 86(6): p. 1221-5.
25. Eitzen, I., Pressure mapping in seating: A frequency analysis approach. *Archives of Physical Medicine and Rehabilitation*, 2004. 85: p. 1136-1140.
26. Reenalda, J., et al., Clinical use of interface pressure to predict pressure ulcer development: a systematic review. *Assist Technol*, 2009. 21(2): p. 76-85.
27. Stinson, M., et al., Spinal cord injury and pressure ulcer prevention: using functional activity in pressure relief. *Nursing research and practice*, 2013. 2013: p. 860396.
28. Maurer, C.L. and S. Sprigle, Effect of seat inclination on seated pressures of individuals with spinal cord injury. *Physical therapy*, 2004. 84(3): p. 255-61.
29. Sprigle, S., W. Dunlop, and L. Press, Reliability of bench tests of interface pressure. *Assist Technol*, 2003. 15(1): p. 49-57.

PS8.2: RCT on Wheeled Mobility for Pressure Injury Prevention

David Brienza, PhD

Patricia Karg, MS

Marnie Bertolet, PhD

Mark Schmeler, PhD, ATP

Prerna Poojary-Mazzotta, MS

Debora Wilkinson, OTR/L, ATP

Background

Pressure injuries (ulcers) are a significant healthcare problem for nursing home residents. The Centers for Medicare and Medicaid Services (CMS) reported that more than 1.4 million residents of the United States were living in nursing homes in 2012 [1]. CMS also reported a national prevalence rate of 5.4% for stage 2 or greater pressure injuries in the approximately 1.4 million residents of the United States living in nursing homes. In 2012, 14% of the CMS nursing home surveys resulted in a deficiency for failure to treat or prevent pressure injuries [1]. These failures to provide adequate care indicate a need for the development and demonstration of effective prevention strategies.

Most pressure injuries are avoidable with the application of best practices and with the proper use of existing technology [2]. Immobility and diminished activity are two of the most commonly identified risk factors in the formation of pressure injuries [3-9]. The wheelchair is an important mobility intervention in long-term care settings. Data from a survey showed that adults 65 years of age and over are more than four times more likely than the general population to use wheelchairs [10]. Although the majority of elderly long-term care residents use wheelchairs, these wheelchairs are an overlooked and misunderstood intervention for preventing pressure injuries and enhancing function. When wheelchairs are properly selected and fitted, they can enhance mobility, activity and participation for the user [11]. Poor wheelchair fit leads to an individual adopting postures that increase pressure over bony prominences, reduces an individual's ability to propel the wheelchair and limits the ability to reach forward and side to side [12]. Without evidence to support proper wheelchair assessment and use for preventing pressure injuries and improving function, there is a lack of proper clinical services and availability of funding. The end result is the majority of residents are not fitted with an appropriate wheelchair and cushion, and provided adequate positioning, comfort and pressure injury prevention.

Our previous RCT showed the use of a skin protection cushion with an individually-configured manual wheelchair reduced the incidence of pressure injuries [13]. The properly fitted wheelchair was provided to both the treatment and

control groups to isolate the effects of the cushion (skin protection vs. cross-cut foam). However, in practice, most nursing home residents use facility-supplied wheelchairs for mobility that are not individually configured to meet clinical needs. As a result, residents use wheelchairs that can promote poor posture, reduce function and limit their mobility. This previous RCT demonstrated that the skin protection cushions were superior, however since all participants received individually configured wheelchairs, we could not determine the effect of the wheelchair on the incidence of pressure ulcers. However, a significant difference in pressure injury incidence was observed related to propulsion and function. This suggested that the wheelchair might have had an effect. To study the effects of the wheelchair, we proposed this second study, an RCT on wheeled mobility for preventing pressure injuries, to assess whether individually-configured, lightweight manual wheelchairs used with skin protection cushions lower pressure injury risk. The secondary aim was to determine the impact of a properly fitted, lightweight manual wheelchair on functional outcomes.

Methods

The subjects recruited were at risk for developing pressure ulcers and used a manual wheelchair as the primary means of mobility. The inclusion criteria were 60 years or older, Braden Scale score of 18 or less, combined Braden activity and mobility score of 5 or less, manual wheelchair user for at least 6 hours a day on average, and ability to accommodate clinical needs with the wheelchair selected for the study (Sunrise Medical Breezy Ultra 4).

The subjects were randomized by a 1:1 allocation scheme to a treatment or control group. The treatment group received a seating and mobility assessment and individually configured lightweight wheelchair (Sunrise Medical Breezy Ultra 4, HCPCS K0004) along with a skin protection cushion. The control group received a skin protection cushion and related wheelchair adjustment for use with the wheelchair provided by the nursing home. Cushions were selected from three types, the Sunrise Medical J3, Comfort Company Vicair and the ROHO Quadro. Basic wheelchair skills were demonstrated to all participants. The subjects were followed on a weekly basis until a study endpoint of 26 weeks, a seated surface pressure injury, or death occurred.

The goal of the clinical intervention for the treatment group was to provide a skin protection cushion and optimize the participants' positioning and functional mobility in the study issued configurable, lightweight wheelchair. The goal of the clinical intervention for the control group was to provide a skin protection cushion and maintain positioning in the wheelchair issued by their facility. Although the initial study design was intended to not make changes to the nursing home wheelchair for the control group, some related adjustments had to be made to accommodate the study cushions and achieve ethical treatment with respect to posture, comfort and safety. In the follow up period, positioning and wheelchair maintenance issues were assessed. Adjustments were made to the cushion (control and treatment) and wheelchair (treatment) to address positioning as needed.

Pressure injury development on the seated surface was the primary outcome measure, which included pressure injuries on the ischial tuberosities, sacrum or coccyx. A masked skin assessor performed skin assessments weekly. Secondary outcome measures for wheelchair function and mobility included the Functioning Everyday with a Wheelchair Capacity (FEW-C) [14, 15], and Nursing Home Life Space Diameter (NHLSD) [16, 17]. The FEW is a self-report outcome measurement tool administered over time to consumers of wheeled mobility and seating technology. The study used a component of the FEW, the FEW-Capacity (FEW-C), which was developed with the same 10-item content of the FEW self-report and modeled after the performance assistance self-care skills. It has two components that measure functional independence and functional safety in a wheelchair. The FEW-C was measured before study intervention, 14 days after intervention and at study endpoint. The NHLSD is a tool used to calculate a nursing home resident's life space in the previous two weeks. The NHLSD was measured just before study intervention and at endpoint.

The primary objective of the trial was to compare the rate of pressure injuries in participants using facility wheelchairs with a skin protection cushion with those using adjustable lightweight (K0004) wheelchairs and a skin protection cushion. Data were summarized as mean and standard deviation for continuous variables and as frequencies for categorical data. Comparison of baseline characteristics was performed using two sample t-tests for continuous data and Chi square or Fisher's Exact for discrete data. Function and mobility were evaluated using changes in the FEW-C and NHLSD scores between the various time points (pre-randomization, two weeks, and endpoint) and compared between treatment groups using two sample t-tests. The participants included in the comparison of scores across time points was lower than the number of participants enrolled in the study due to drop-out.

Results

A total of 258 nursing home residents were enrolled, 127 in the treatment group and 131 in the control group. Seventeen nursing homes participated. Participants had a mean age of 89.08.9 years, 78% were female and 92% Caucasian. Twenty percent had a previous history of pressure ulcers, 77% were incontinent, 55% could not ambulate any distance, 78% had kyphosis, and 72% a pelvic tilt. There were no significant differences in baseline characteristics between the two intervention groups. There were also no significant differences in independence/dependence in feeding, dressing, hygiene, sitting balance, transfers, ambulation and wheelchair propulsion.

Figure 1 presents the flow of participants and endpoints reached. The primary outcome was incidence of a pressure injury. Of the participants reaching a study endpoint (N=191), 34 (13.2%) developed a pressure injury, 19 (18.6%) in the treatment group and 15 (16.9%) in the control group, $p=0.77$. The function and mobility scores at pre-randomization, 2 weeks and endpoint were compared between groups. Significant differences were observed between groups for the change in FEW-C independence scores between pre-randomization and endpoint (Treatment, $n=88$, change =1.4, Control, $n=85$, change=-0.2, $p=0.03$) and pre-randomization and 2 weeks (Treatment $n=106$, change=0.9; Control $n=99$,

change=-0.3, $p=0.04$), and change in FEW-C safety scores between the pre-randomization and endpoint (Treatment $n=88$, change=0.5; Control $n=85$, change=-0.7; $p=0.06$). The mean FEW-C independence and safety scores for the treatment group improved during the study follow up period, whereas the control group scores declined. No significant differences in mean FEW-C scores between groups were found at any time point (pre-randomization, 2 weeks, or endpoint). The NHLSD scores were not significantly different at pre-randomization (Treatment, $n=89$, score=29.0; Control, $n=85$, score=29.1; $p=0.97$). The NHLSD scores increased for the treatment group and decreased for the control group, but the mean scores were not significantly different between the groups at endpoint (Treatment, $n=89$, score=31.0; Control, $n=85$, score=26.7; $p=0.07$), and the change in score between the pre-randomization and endpoint was also not significantly different (Treatment, $n=89$, change=2.0; Control, $n=85$, change=-2.4; $p=0.07$).

Discussion

The treatment group did not have a lower incidence of pressure injuries than the control group. We expected that the subjects using the facility wheelchairs would be at risk of sitting in a posture that would expose their sacrum to potentially harmful pressure and shear, while the subjects in the treatment group would be provided superior posture by virtue of the fit and features of the wheelchair. Seating interventions for the control group tended to target providing increased comfort and better pelvic positioning for the study participant. While the intent of the study was not to alter the general positioning of the control participant, related adjustments had to be made to accommodate the study cushions and achieve ethical treatment with respect to posture, comfort and safety. The application of the study cushion lent itself to improved pelvic positioning and posture, due to the specific contour and support provided. With this improved pelvic positioning and posture in both groups, additional benefits of a lightweight and configurable wheelchair for the treatment group did not make a difference in pressure injury outcomes.

The treatment group did, however, improve significantly more than the control group between pre-randomization and endpoint with respect to functional independence and safety. Seating interventions for the treatment group were targeted to improve clinical outcomes for the participant. For example, provision of adjustable height armrests allows for improved shoulder and arm support, improved posture, and reduced pain. Adjustable tension backs improve posture, pelvic positioning, comfort and ultimately function by accommodating skeletal deformities. Adjustable height backs and canes prevent undue pressure on the scapulae and shoulders, improve mobility by allowing more freedom of movement when self-propelling, and improve overall comfort of the seating system. Addition of brake extensions allows for improved safety and decreased pain, as participants were able to more easily and independently apply the brakes. Brake extensions also allow for improved function in activities of daily living (ADL) and mobility tasks as they improve wheelchair stability when the brakes are applied. An adjustable height wheelchair improves overall posture, wheelchair mobility for foot propellers, and function in ADL tasks by improving reach.

Problems encountered by the control group were sliding out of the chair in cases where the study issued cushion was higher than the facility issued cushion. There were instances where, despite the addition of a drop seat, the chair was too high for a foot propeller, they would move forward in the seat to get their feet to touch the floor and then start to slide. This was unavoidable since most chairs could not be adjusted to a lower height. If the facility issued chair did happen to have an axle height adjustment, the height was adjusted to allow the chair to be lower to the ground, thus allowing the person who had previously been a foot propeller with a lower height, facility issued cushion, to foot propel with the new, higher study cushion. In some cases, when the participant continued to slide and became an increased fall risk, they were withdrawn from the study.

Treatment group study participants were given the most appropriate equipment possible to optimize their seating and attain the best positioning and functional outcomes possible. In the case of the control group, the study participants did not attain the most optimal seating and positioning due to the significant limitations imposed by the facility issued wheelchairs. Adding a drop seat and/or adjusting the footrests to accommodate the increased height of the study cushion may have improved function and positioning, but did not allow the study participant to attain optimal positioning and function.

Acknowledgements

This work was supported by a grant the Eunice Kennedy Shriver National Institute of Child Health and Human Development (NICHD), National Center for Medical Rehabilitation Research Grant #R01HD04109. Manufacturers supplied wheelchairs and cushions for the study at cost. None of the authors have any financial interests in or affiliations with the companies that manufactured the products used in this study.

References

1. Centers for Medicare and Medicaid Services, Nursing home data compendium 2013 edition, in http://www.cms.gov/Medicare/.../nursinghomedatacompendium_508.pdf. 2013: Baltimore, MD.
2. Black, J.M., et al., Pressure ulcers: avoidable or unavoidable? Results of the national pressure ulcer advisory panel consensus conference. *Ostomy-Wound Management*, 2011. 57(2): p. 24.
3. Bergstrom, N., et al., The Braden Scale for Predicting Pressure Sore Risk. *Nursing Research*, 1987. 36(4): p. 205-10.
4. Brandeis, G.H., et al., A longitudinal study of risk factors associated with the formation of pressure ulcer in nursing homes. *Journal of American Geriatric Society*, 1994. 22: p. 128-134.
5. Allman, R.M., et al., Pressure ulcer risk factors among hospitalized patients with activity limitation. *JAMA*, 1995. 273(11): p. 865-70.
6. McGowan, S., Hensley, L., Maddock, J., Monitoring the occurrence of pressure ulcers in a teaching hospital: a quality improvement project. *Primary Intention*, 1996(4): p. 9-19.
7. Wright, R. and A. Tiziani, Pressure ulcer point prevalence study. *Primary Intention*, 1996. 4(1): p. 18-23.
8. Pase, M.N., Pressure relief devices, risk factors, and development of pressure ulcers in elderly patients with limited mobility. *Advances in Wound Care*, 1994. 7(2): p. 38-42.
9. NPUAP/EPUAP/PPPIA, National Pressure Ulcer Advisory Panel/European Pressure Ulcer Advisory Panel/Pacific Pressure Injury Alliance: Prevention and Treatment of Pressure Ulcers: Clinical Practice Guideline. <http://internationalguideline.com/>, ed. E. Haesler. 2014, Perth, Australia. 1-308.
10. Kaye, S.H., Computer and Internet use among people with disabilities. 2000, National Institute on Disability and Rehabilitation Research: Washington, DC. p. 10.
11. Engström, B., Ergonomics Seating: A True Challenge. *Wheelchair Seating & Mobility Principles*. 1993: Posturalis Books. Stockholm, Sweden.
12. Gavin-Dreschnack, D., et al., Wheelchair-related falls: current evidence and directions for improved quality care. *Journal of nursing care quality*, 2005. 20(2): p. 119-127.
13. Brienza, D., et al., A randomized clinical trial on preventing pressure ulcers with wheelchair seat cushions. *Journal of the American Geriatrics Society*, 2010. 58(12): p. 2308-2314.
14. Mills, T.L., M.B. Holm, and M. Schmeler, Test-retest reliability and cross validation of the Functioning Everyday with a Wheelchair instrument. *Assistive Technology*, 2007. 19(2): p. 61-77.
15. Schmeler, M.R. Wheelchair functional outcomes measures & functioning everyday with a wheelchair tools. in *Canadian Seating and Mobility Conference*. 2006.
16. Peel, C., et al., Assessing mobility in older adults: the UAB Study of Aging Life-Space Assessment. *Physical Therapy*, 2005. 85(10): p. 1008-1019.
17. Tinetti, M.E. and S.F. Ginter, The Nursing Home Life-Space Diameter. *Journal of the American Geriatrics Society*, 1990. 38(12): p. 1311-1315.

Figure 1. Participant flowchart

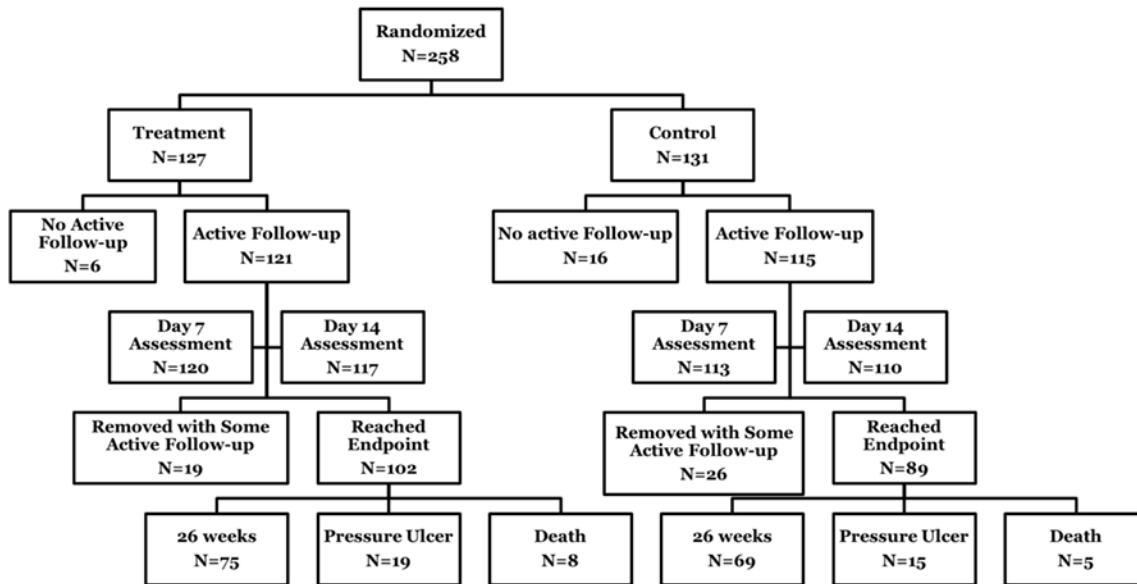

Alternate text: Figure 1 is a flowchart showing randomization to treatment (n=127) and control groups (n=131). In the treatment group 121 had active follow-up and 102 reached an endpoint (75 reached 26 weeks, 19 got a pressure ulcer, 8 died). In the control group 115 had active follow-up and 89 reached an endpoint (69 reached 26 weeks, 15 got a pressure ulcer, 5 died).

PS8.3: Design and Verification of a Paediatric Wheelchair Cushion

Maighread M Ireland, MEng
Laura Finney, PhD, MSc, BEng, CEng

Background

A literature review has highlighted the danger of extrapolating adult data for design of paediatric support services (Levy, Kopplin, & Gefen, 2015) (Burdi, Huelke, Snyder, & Lowrey, 1969). Paediatric body dimensions, biomechanical properties of soft tissues and daily activities are different to adults; hence for design purposes, a child cannot be considered as a scaled-down adult. This study involved the design, verification and validation of a paediatric wheelchair cushion, based specifically on paediatric requirements and dimensions.

Methods

Stage 1: Requirements specification

First stage of the project was to identify and document the requirements that the design must satisfy. A comprehensive requirements specification may increase quality of the product and reduce design time and costs (Alexander, Clarkson, Bishop, & Fox, 2001)

Multiple sources were used to compile the requirements specification:

1. Clinical requirements were gained from a questionnaire being sent to X clinicians working in seating and postural services across the National Health Service, England. Opinions on currently used products, and desired characteristics for a paediatric wheel-chair cushion were collected.
2. Market trends were identified by contacting product advisors in several international markets (Australis, Germany, America and Italy). Specific questions were asked, and feedback was collected on the trends from each market.
3. Regulatory requirements were gained from ISO Standard 16840-2: Wheelchair seating-Part 2 and Part 9.
4. The seating-system that the cushion will predominantly be used in combination with was reviewed. Postural supports provided by the mechanical seating-system were identified.

Feedback from these sources was reviewed and combined to develop the functional specification. The MoSCoW (Clegg & Barker, 2004) prioritising technique was used to prioritise requirements in terms of importance.

Stage 2: Design Prototypes

Concepts were created and several phases of prototypes developed. Re-designs were required as a result of verification activities or the identification of errors in design. This resulted in several versions of the requirements specification. Published literature was studied in parallel to re-designs to gather evidence of methods used for postural support, particularly in terms of shape and cushion material.

Stage 3: Validation and verification of prototypes

Requirements should have an associated performance target that can be measured in order to verify that the requirement has been met (Alexander et al., 2001). Verification methods with quantitative outcomes used in the project were:

1. A paediatric wooden rigid cushion loading indenter (PRCLI) was constructed under guidance from ISO 16840-2:2007, and paediatric anthropometric data (Reed, Sochor, Rupp, Klinich, & Manar, 2009) to objectively compare design prototypes. The adult RCLI has been proven to differentiate wheelchair cushion performance (Hollingtona, Hillmana, Sánchezb, Boeckxb, & Crossanb, 2014).
2. XSENSOR® pressure map readings were used to measure and map the pressures occurring at the patient-cushion interface. ISO 16840-9:2015-Clinical interface pressure mapping guidelines were followed.

However if requirements could not be defined quantitatively, evaluation against qualitative criteria was used:

1. Multi-disciplinary design review meetings were held throughout the project to evaluate prototypes against requirements specification.
2. Clinical testing was carried out on prototypes in likeness to final product.

Stage 4: Risk Management

Risk management was used to identify weaknesses in the design. In the later stages of the project as the design became more detailed, risk management was used to ensure robustness and safety.

Findings

Stage 1: Requirements Specification

The questionnaires confirmed that both shape and postural requirements vary greatly with age. In general, children require increasing accommodation of bony and neuromuscular deformity with age but sometimes decreasing postural support due to the development of sitting balance.

An important clinical requirement was for the cushion to allow for growth and the associated shape / function change. This highlighted the need for a cushion to have adjustability, ensuring it can facilitate changes in the user's anatomy during its life-time.

A factor associated with pressure issues is impaired mobility and a sedentary lifestyle (Bouten, Oomens, Baaijens, & Bader, 2003). From feedback these risk factors were reported as less prevalent in paediatrics due to the nature of daily activities provided for children, compared to adults.

The ability of a deep-contoured to support the user in a stable and neutral posture, was an important feature for paediatrics. The lack of colourful wheelchair covers was also highlighted from client feedback. A feature which may possibly be considered minor but for paediatric users it is an important aspect.

Stage 2: Prototype Design

Published literature was consulted in selecting cushion materials and cushion shape (European Pressure Ulcer Advisory Panel and National Pressure Ulcer Advisory Panel, 2014) (Ferguson-Pell, 1986). The benefits of a multi-layer cushion were established (see Table 1), where the function of each layer defines the material characteristics.

Layer	Function	Material Requirements
Cover	Skin contact interface, and the 'face' of cushion.	Smooth, strong, light, flexible, material that is adequate to support and transport the cushion, porous, two-way stretch, easily cleaned and aesthetically suitable for paediatric users.
Top Layer	Encourage air circulation and reduce sitting pressure.	A breathable soft open-cell or reticulated foam; thickness 0.5-1.0 inches recommended.
Middle Layer	Reduce pressure and shear forces, and control heat dissipation.	Various medium or high density foams and gel components; 1.0-2.0 inches thick can be used.
Base	Prevent cushion from bottoming out.	A high firmness foam base is required.

Table 1: Components of a multi-layer cushion, where each layer contributes to the overall properties of the cushion.

Interface pressures under vulnerable bony prominences of the pelvis can result in unwanted pressure issues for wheelchair users (Bouten et al., 2003). The shape of a wheelchair cushion can help distribute pressure evenly over the cushion contact area, helping to reduce peak pressures under the bony prominences. A cut-out or flotation shape can be used to facilitate this off-loading in wheelchair cushion design (Crane, Winger, & Call, 2016), (Ferguson-Pell, 1986), (Rosenthal et al., 1996).

Paediatric anthropometric values of the pelvis were used to determine the appropriate shape of the cut-out region, dimensions used were the lateral distances between the left and right ischial tuberosity's and the trochanter region (Reed et al., 2009).

Ramped cushions have been commonly used in wheelchair seating to accommodate the femur in a horizontal position (Mulcahy & Pountney, 1987). This reduces the tendency to sacral seat, which can cause unwanted excessive pressure on the sacrum. A ramp of 15° from the gluteal fold to the popliteal fossa has been reported to facilitate this posture (Mulcahy, Pountney, Nelham, Green, & Billington, 1988). However recent studies have shown that a reduction in ramp angle results in optimal femoral orientation and seated pressure distribution (Newe & Colvin, 2016).

Stage 3: Verification and Validation

The PRCLI allowed the recovery characteristics of cushion prototypes to be examined, i.e. the cushions ability to recover to its original shape and size when unloaded (Hollington, Hillman, Torres-Sánchez, Boeckx, & Crossan, 2014). This can

be seen as both a negative and positive aspect of a cushion. A cushion with high recovery, may tend to push back at the user when compressed possibly causing tissue compression. However a cushion with low recovery, may not provide sufficient postural support as it will not recover after being compressed.



Figure 1: PRCLI attached to a pneumatic testing rig, applying load to a cushion prototype

Figure 2 shows the loading and unloading plots of the ethafoam base (A), and a multi-layer prototype which is a combination of ethafoam, open cell reticulated, and memory foam (B). The shallow gradient of the ethafoam base demonstrates the stiffness of this foam. This was a requirement of the layer as it will provide the stable, deep-contoured shape.

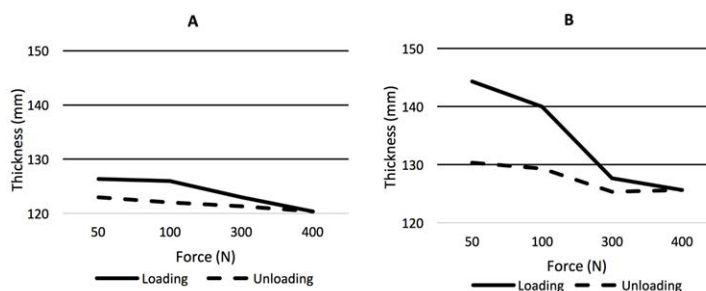

Figure 2: Load deflection plots for black ethafoam, and the multi-layer foam prototype. Values are averaged over three cycles as specified by ISO 16840-2:2007.

When the ethafoam is used in combination with multiple foam layers a steeper curve is observed. This would indicate a more compliant cushion, with the ability to contour around the pelvis. This was a desirable function of using a combination of foam densities and firmness. The ethafoam provides a stable, anchor base, while layers on-top provide material to envelop the pelvis to increase the load bearing area.

XSensor® pressure map readings were taken following ISO 16840-9:2015 guidance; peak pressure index (PPI), and contact area (CA) statistical analysis outputs were compared. This helped to inform decisions on shape and material selection throughout the project.

Final designs were validated using an Evidence based Practice approach, that is: clinical pressure mapping, feedback from clinicians and input from children themselves.

Conclusion

Feedback highlighted important features related to paediatric wheelchair users, which allowed a comprehensive requirements specification to be developed. Clinical feedback highlighted the need for adjustable deep-contouring to provide stability, optimise pressure distribution, adapt to growth and accommodate deformity.

The PRCLI and pressure mapping provided a quantitative method of verification of prototypes. This enabled objective decision making during the design process, thus increasing the safety, quality and reliability of the design.

References

1. Alexander, K., Clarkson, J., Bishop, D., & Fox, S. (2001). Good design practice for medical devices and equipment - a framework. University of Cambridge Engineering Design Centre and University of Cambridge Institute for Manufacturing.
2. Bouten, C. V., Oomens, C. W., Baaijens, F. P., & Bader, D. L. (2003). The etiology of pressure ulcers: Skin deep or muscle bound? *Archives of Physical Medicine and Rehabilitation*, 84(4), 616–619. <http://doi.org/10.1053/apmr.2003.50038>
3. Burdi, A., Huelke, D., Snyder, R., & Lowrey. (1969). Infants and children in the adult world of automobile safety design: paediatric and anatomical considerations for design of child restraints. *J Biomech*, 2(3), 267–280.
4. Clegg, D., & Barker, R. (2004). *Case Method Fast-Track: A RAD Approach*. Addison-Wesley.
5. Crane, B., Winingar, M., & Call, E. (2016). Orthotic-Style Off-Loading Wheelchair Seat Cushion Reduces Interface Pressure Under Ischial Tuberosities and Sacrococcygeal Regions. *Archives of Physical Medicine and Rehabilitation*.
6. European Pressure Ulcer Advisory Panel and National Pressure Ulcer Advisory Panel, P. P. P. I. A. (2014). *Prevention and Treatment of Pressure Ulcers : Quick Reference Guide*. Clinical Practice Guideline.
7. Ferguson-Pell, M. (1986). *Technical Considerations, Seat Cushion Selection*.
8. Hollington, J., Hillman, S., Torres-Sánchez, C., Boeckx, J., & Crossan, N. (2014). ISO 16840-2:2007 load deflection and hysteresis measurements for a sample of wheelchair seating cushions. *Medical Engineering and Physics*, 36(4), 509–515.
9. Hollingtona, J., Hillmana, S., Sánchezb, C., Boeckxb, J., & Crossanb, N. (2014). ISO 16840-2:2007 Load deflection and hysteresis measurements for a sample of wheelchair seating cushions. *Med Eng Phys*, 36(4), 506–515.
10. Levy, A., Kopplin, K., & Gefen, A. (2015). Adjustability and Adaptability Are Critical Characteristics of Paediatric Support Surfaces. *Adv Wound Care*, 4(10), 615–622.
11. Mulcahy, C., & Pountney, T. (1987). Ramped Cushion. *British Journal of Occupational Therapy*, 50(97).
12. Mulcahy, C., Pountney, T., Nelham, R., Green, E., & Billington, G. (1988). Adaptive Seating for the Motor Handicapped — Problems, a solution, assessment and prescription. *British Journal of Occupational Therapy*, 51(10).
13. Newe, C., & Colvin, J. (2016). Examining the impact of cushion design on posture and pressure distribution.
14. Reed, M., Sochor, M., Rupp, J., Klinich, K., & Manar, M. (2009). Anthropometric specification of child crash dummy pelvis through statistical analysis of skeletal geometry. *J Biomech*, 42(8), 1143–1145.
15. Rosenthal, M. J., Felton, R. M., Hileman, D. L., Lee, M., Friedman, M., & Navach, J. H. (1996). A wheelchair cushion designed to redistribute sites of sitting pressure. *Archives of Physical Medicine and Rehabilitation*, 77(3), 278–282. [http://doi.org/10.1016/S0003-9993\(96\)90112-4](http://doi.org/10.1016/S0003-9993(96)90112-4)

PS8.4: Simulating Terrain for Measuring Wheelchair Rolling Resistance

Patrick Joeseeph Barba, BS/MEng

While ease-of-function in various terrains is important for wheelchair users in modern nations, for those in less resourced environments it can be a life threatening concern. In locations with rough pavement, dirt paths, and few smooth sidewalks, the difficulty of rolling causes physical exertion that can either compromise the user's health or cause them to avoid traveling outside their home.

One aspect of wheelchair function is the rolling resistance of the wheels. Different types and sizes of wheels roll more easily over different surfaces. There are commercial methods of measuring rolling resistance of common bicycle and automobile wheels assuming a smooth surface. However measuring wheel characteristics over such surfaces as brick pavers and grass paths is problematic.

The authors developed an instrumented three-wheeled cart and measured the force required to pull the cart over different surfaces at a constant velocity. By using the same wheels at with the same loading, they were able to identify simple surfaces that would simulate the complex terrains of local environment. This will allow manufacturer's to compare wheel/tire combinations based on rolling performance, not just on smooth floors, but on natural terrain.

Learning Objectives:

Upon completion of this session, attendees will be able to;

- List two principles of the physics of rolling resistance.
- Identify five factors that impact ease of wheelchair rolling.
- List the impacts on rolling resistance of three different terrains.

References:

1. Sauret, C., Vaslin, P. Bascou, J., Pillet, H., & Lavaste, F. (2011). Rolling resistance index of manual wheelchairs. *Computer Methods in Biomechanics and Biomedical Engineering*, 14(S1), 65-66.
2. Van der Woude, L.H.V., Geurts, C., H. Winkelman, & Veeger, H.E.J., (2003). Measurement of wheelchair rolling resistance with a handle bar push technique. *Journal of Medical Engineering & Technology*, 27(6), 249-258.
3. Frank, T.G. & Abel, E.W, (1989). Measurement of the turning, rolling, and obstacle resistance of wheelchair castor wheels. *Journal of Biomedical Engineering*, 11(11), 462-466.

Saturday

March 4, 2017

IC65: Maximizing Outcomes In Step with Advancing Technology

Amy Morgan, PT, ATP

Wendy Koesters, PT, ATP/SMS

Abstract

Seating and wheeled mobility technology is advancing rapidly, and it may seem difficult to keep up with the many options that are available for wheelchair users. Often, a wheelchair user is instructed in a basic level use of their equipment at delivery and the more advanced features that their chair is capable of are not utilized. It is nearly impossible for a single provider to thoroughly apply appropriate technology for various aspects of someone's lifestyle and medical needs; a team approach is critical to thoroughly maximize a person's ability to utilize comprehensive assistive technology options. This workshop will use recent case studies to examine solutions to problems we commonly encounter in real world applications. A practical framework to implement best practice as recommended by the RESNA Wheelchair Service Provision Guide will be shared as well.

Introduction

The wheelchair features, fit and setup can have major effects on skill performance. In helping improve the safety, effectiveness and efficiency of wheelchair use, the rehab team should try to optimize the wheelchair user (e.g. by improving strength or range of motion), the wheelchair (e.g. adjusting the programming of a powered wheelchair) and/or training. Successful use of the power wheelchair, however, goes beyond the driving capabilities of the wheelchair. During this session, the following features of power wheelchairs will be discussed and case studies will be used to demonstrate the effectiveness and application of each. Specific Features to Improve Function/Use of Power Wheelchairs:

- **Memory Seating:** This feature is ideal for pressure relieving positions, but can also be utilized for functional positions a client encounters on a regular basis. Memory positions are most effectively utilized in combination with programmable/assignable buttons or switches (see below).
- **Programmable Buttons/Switches:** By assigning a function to a specific button or switch, it makes achieving that feature more efficient and simplifies the process. Buttons/Switches can be assigned as seat functions or memory positions as well as other "modes" or things that the power wheelchair can do (ex. Mouse emulation, phone access, Infrared commands, etc.)
- **Virtual Seating Coach:** The Virtual Seating Coach is unique to Permobil power wheelchairs. It utilizes a Smart Phone or Tablet application to remind clients to complete their repositioning. It also coaches them to get to the proper position and stay in that position for the correct

amount of time. The Virtual Seating Coach has been shown to improve compliance by 40% in pilot studies (Wu, 2015).

- **Power Anterior Tilt:** Anterior Tilt is available in varying degrees and is commonly used to assist with transfers, reaching tasks, functional activities, and tone management. It can also be used in a somewhat "non-traditional" way to improve visual interaction/scanning the environment for safety.
- **Standby Select:** Standby select is a feature that allows the client to access all functions of the chair through the joystick without pressing any buttons. It is most applicable for clients who have difficulty getting their hand on and off the joystick. Standby select allows the client to keep their hand on the joystick.

Conclusion

It is important to work as a team to achieve the best outcome for each individual client. Each member of the team (client, clinician, equipment provider, manufacturer) brings a unique perspective and expertise to the problem solving that regularly is required for users of complex rehab power mobility. The team approach is commonly utilized at the initial prescription phase for equipment, but often, the delivery of the equipment is done without team input. When possible, it is best practice to deliver a client's equipment in a clinic setting with the prescribing clinician and ATP/provider present. This framework is supported by the Wheelchair Service Provision Guideline from RESNA and helps ensure best practice and optimizes use of a client's technology (Arledge, et.al., 2011).

References:

1. Arledge, S.; Armstrong, W.; Babinec, M.; Dicianno, B.E.; Digiovine, C.; Dyson-Hudson, T.; Pederson, J.; Piriano, J.; Plummer, T.; Rosen, L.; Schmeler, M.; Shea, M.; and Stogner, J. (2011). RESNA Wheelchair Service Provision Guide.
2. Dicianno, B.E.; Liberman, J.; Schmeler, M.R.; Schuler, A.E.; Cooper, R.; Lagne, M.; et al. (2015). RESNA Position on the Application of Tilt, Recline, and Elevating Legrests for Wheelchairs Literature Update.
3. Ding, D., Liu, H., Cooper, R., Cooper, R., Smailagic, A., and Siewiorek, D., (2010). "Virtual Coach Technology for Supporting Self-Care." *Physical Medicine Rehabilitation Clinic North America*. 21: 179-194.
4. Ding, D., Leister, E., Cooper, R., Cooper, R., Kelleher, A., Fitzgerald, S., Boninger, M. (2008). "Usage of Tilt-In-Space, Recline, and Elevation Seating Function in Natural Environment of Wheelchair Users." *Journal of Rehabilitation Research & Development*. 45(7): 973-984.
5. Liu, H. (2013). "Development of a Customized Electronic Reminder to Facilitate Powered Seating Function Usage and Compliance with Clinical Recommendations: Design Process and Clinical Efficacy." Submitted to the Graduate Faculty of School of Health and Rehabilitation Science and Technology in Partial Fulfillment of the Requirements for the Degree of Doctor of Philosophy, University of Pittsburgh.

-
6. Mountain, A.D., Kirby, R.L., Eskes, G.A., Smith, C., Duncan, H., MacLeod, D.A., & Thompson, K. (2010). Ability of people with stroke to learn powered wheelchair skills: a pilot study. *Archives of Physical Medicine and Rehabilitation*, 91(4), 596-601.
 7. Wu, Y. (2015). "Development and Evaluation of a Smartphone Virtual Application to Facilitate Powered Seat Function usage for Powered Wheelchair Users." Submitted to the Graduate Faculty of School of Health and Rehabilitation Sciences in Partial Fulfillment of the Requirements for the Degree of Doctor of Philosophy, University of Pittsburgh.

Contact Information

Amy Morgan, PT, ATP

Permobil, Inc.
amy.morgan@permobil.com

Wendy Koesters, PT, ATP/SMS

The Ohio State University
wendy.koesters@osumc.edu

IC66: Air Travel with a Wheelchair: What Seating Experts Should Know

Jessica Presperin Pedersen,
OTR/L, ATP
Mary Shea, OTR/L, ATP/SMS

Airline travel provides a means to traverse the globe for business or pleasure. This session will focus specifically on individuals who use a wheelchair and are interested in airline travel. The airline travel process will include making a reservation, navigating the airport and security, boarding the aircraft, sitting on the aircraft seat, and stowage of the wheelchair. Practical experience, clinical expertise, evidence-based information from hands-on research performed at Beneficial Designs and the Rehabilitation Institute of Chicago, and feedback of over 700 respondents on a SurveyMonkey® pertaining to experiences flying on commercial airlines will be shared.

When making a reservation, disclosure of a disability and specific equipment being used will help the service providers at the airport and specific airline to make note of the wheelchair use to assist the person and the wheelchair. The process of making a reservation, establishing a contact at the airport and airlines, and navigating TSA will be discussed.

Depending on an individual's level of function and his/her wheelchair, boarding the aircraft can be performed several different ways. This includes using a manual wheelchair to transfer to the first few seats if certain airlines or aircraft are used. Some individuals have the ability to navigate the narrow aisles using their own wheelchairs with the wheels off and specialized anti-tip like wheels attached to their wheelchair. Otherwise, a particular individual may need to transfer onto a boarding device to get down the aircraft aisle to his/her seat. Research pertaining to three boarding devices ("aisle chairs") used to board an aircraft will reflect ease of transfer, comfort and stability during transport, and interface pressure mapping results with sitting on the boarding device.

During transit, individuals may need to use other assistive technologies to help with sitting tolerance, skin protection, and posture. It is advisable to use the wheelchair cushion, although the height of a pressure distributing cushion can be an issue. For an air cushion, it is important to remember that air in the cushion will change due to the atmospheric pressure. The air would need to be released as the cushion became filled with air and refilled once the aircraft has landed. A secondary flight seat cushion might be another option for a lower height option to enable the person to get sufficient support from the floor and armrests. Commercially available products such as neck pillows, lumbar rolls, foot support, and other airline seat supports may be helpful. In some cases, individuals may purchase something normally used in wheelchairs to assist with positioning in the aircraft seat.

Getting to and using the lavatory on the aircraft may or may not be possible depending on the type of aircraft and the size of the lavatory. Compensatory techniques for bladder management, avoiding accidents, dehydration, and other potential problems will be discussed.

Once a traveler lands at their destination, the biggest concern is what type of condition the wheelchair will be in. Due to the different types of stowage openings on various aircrafts and different airline personnel at the destination airport, it is essential for the individual in a wheelchair to be able to direct airline personnel on strategies to protect the wheelchair and what to do if there is damage or loss. Ideas on how to work with the below-the-wing crew, protect the wheelchair, and what to do if there is loss or damage will be discussed.

References

1. Darcy, S. (2012). (Dis)embodied air travel experiences: Disability, discrimination and the affect of a discontinuous air travel chain, *Journal of Hospitality and Tourism Management*, 19.
2. Presperin Pedersen, J., & Axelson, P. (2016). I'm leaving on a jet plane. I hope I'll see my chair again. In *Proceedings from 32nd International Seating Symposium: Imagine the Possibilities*, Vancouver, British Columbia: University of British Columbia. 247-253.
3. United Spinal Association. (2013). *Accessible air travel: A guide for people with disabilities*. Kew gardens, NY: United Spinal Association.

IC67: Solution to Complex Drive Systems with the ALS Population

Pamela Glazener, OTR, ATP

Gina Strack, ATP, OT

Amyotrophic lateral sclerosis (ALS), also known as Lou Gehrig's Disease, is a progressive neurodegenerative disease involving loss of both upper and lower motor neurons resulting in limb muscle weakness, muscle atrophy, speech and swallowing difficulties and respiratory compromise. The progression of symptoms can be rapid, average, or slow. Life expectancy from symptom onset can range widely but is typically referenced to be 3-5 years and there is no known cure for ALS at this time.

The management of patients with ALS has changed and improved dramatically in the past 20 years. Power mobility plays a large role in the current care for these patients. When choosing the appropriate power mobility device and drive controls needs to be carefully evaluated and chosen based on the patient's abilities, disabilities, rate of disease progression, and anticipated changes in the future.

Several ALS patients will be presented in this course - each presenting with varied symptoms, level of function, abilities and rate of progression. Specifics regarding complex drive systems for the different stages of ALS will be discussed. This course will also include documentation guidelines for custom power mobility which can be a challenge for this patient population.

Reference:

1. Clinical care of patients with amyotrophic lateral sclerosis. Radunovic, A., Mitsumoto, H., and Leigh, P.N. *Lancet Neuro* 2007; 6: 913-25.
2. Amyotrophic lateral sclerosis: An Update for 2013 Clinical Features, Pathophysiology, Management and Therapeutic Trials. Gordan, P.H. *Aging and Disease* 2013; 4: 296-310.
3. Physical Therapy for a Patient Through Six Stages of Amyotrophic Lateral Sclerosis. Bello-Haas, V., Kloos, A.D., and Mitsumoto, H. *Physical Therapy* 1998; 78: 1312-1324.

IC68: Research & Evidence-Based Practice for Pressure Management and Tissue Integrity

Brenlee Mogul-Rotman B.Sc.O.T., OT
Reg. (Ont.) ATP/SMS

Research comprises “creative work undertaken on a systematic basis in order to increase the stock of knowledge, including knowledge of humans, culture and society, and the use of this stock of knowledge to devise new applications.”[1] It is used to establish or confirm facts, reaffirm the results of previous work, solve new or existing problems, support theorems, or develop new theories.

Seating and Mobility intervention is a complex combination of assessment, trial, teamwork, prescription, funding, sales, service and provision of information. The team works with the client as a team member and the goal is to provide appropriate devices that fit the client, work within all environments and allow function and daily activities. The devices will assist with postural alignment, skin protection, mobility, stability, comfort and function. We are regularly learning new strategies and using new products. There is consistent product development as well as challenges related to funding, service provision and competency of team members. We are faced with the challenge of maintaining and upgrading our knowledge base, using current strategies and Best Practice methods. There is research and evidence, both old and new, that we must be aware of and analyze as to how it impacts our own knowledge and how we intervene with our clients.

How do the research findings help us as clinicians to practice better and to provide recommendations to our clients? Our daily practice requires that we are up to date on what is current and ‘new’. We are expected to utilize Best Practice methods to ensure that our clients are receiving the intervention appropriate for their situation now and in the future. What we do and recommend to our clients today have implications for their function, health and quality of life in the long term.

Historically, pressure injury etiology has revolved around ischemic changes in the skin, and soft tissue. However, recent evidence has been introduced where tissue deformation of the skin and soft tissue has earlier implications in pressure injury development versus just ischemia alone. It is now understood that there is a difference in development of a superficial pressure injury versus a suspected deep tissue pressure injury.

A pressure injury is defined as “localized damage to the skin and underlying soft tissue usually over a bony prominence or related to a medical or other device. The injury can present as intact skin or an open ulcer and may be painful. The injury occurs as a result of intense and/or prolonged

pressure or pressure in combination with shear. The tolerance of soft tissue for pressure and shear may also be affected by microclimate, nutrition, perfusion, co-morbidities and condition of the soft tissue.” There are a variety of intrinsic and extrinsic risk factors associated with the development of tissue and skin damage and through our seating and mobility devices, modalities and regimens; we attempt to minimize the risk factors to allow our clients safe sitting time and independence.

Following assessment of a client, goals are determined to meet postural and tissue protection needs. We utilize cushions and back supports, bed support surfaces and secondary supports within a seating and mobility system for each client. In addition to the equipment or system itself, we recommend various strategies and regimens for pressure management and repositioning, that we hope our clients are able to and willing to complete. Pressure management maneuvers or ‘weight shifting’ in a wheelchair, use of dynamic seat functions such as tilt/recline and elevating legrests, and standing are all manners in which our clients are able to protect tissues and skin, maintain alignment and function throughout their day as independently as possible.

The method of pressure management through ‘weight shifting’ or ‘pressure relief maneuvers’ as they have been called differs from client to client depending on the client’s abilities and strength. What has not been considered historically when teaching our clients how to perform the various maneuvers is the how the movement itself and the surface being moved upon effects the deep tissues and skin. A different type of pressure management maneuver might be considered for a client depending not only on their ability, but also on the surface underneath their buttocks.

The use of tilt, recline and power elevating legrests for pressure management and postural alignment are all functions that can be utilized separately or in combination with one another. Prescription of these dynamic seat functions is based on client presentation and client need. Recommendations around angles of movement, duration of maintaining a change in position and frequency of changes are all provided based on best practice and experiential knowledge. However, it is noted in the literature that although clients are educated and provided with the equipment, the changes in position do not occur as often or as exact as recommended by the clinician involved. Standing is a well-documented method of redistributing pressures as well as numerous other health, quality of life and functional issues. We must find ways to ensure that our clients are able to utilize the devices provided to them and to ensure that consistent and correct methods are followed.

Research is imperative to furthering our understanding of what we do on a daily basis to assist our clients. Taking the findings and utilizing them to better assist our clients with practical strategies and adaptive device selection is imperative.

References:

1. Brienza, D. et al, (2010). "A Randomized Clinical Trial on Preventing Pressure Ulcers with Wheelchair Seat Cushions." *Journal of the American Geriatrics Society* 58:2308-2314.
2. Ding D, Leister E, Cooper RA, Cooper R, Kelleher A, Fitzgerald SG, and Boninger ML, Usage of tilt-in-space recline, and elevation seating functions in natural environments of wheelchair users. *Journal of Rehabilitation Research & Development*, 2008. 45(7): p. 65-74.
3. Gefen, A. (2014). "Tissue Changes in Patients Following Spinal Cord Injury and Implications for Wheelchair Cushions and Tissue Loading: A Literature Review." *Ostomy Wound Management* 60 (2):34-45.
4. Levy, A, Kopplin, K., Gefen, A. (2014). "An air-cell based cushion for pressure ulcer protection remarkably reduced tissue stresses in the seated buttocks with respect to foams: Finite element studies." *Journal of Tissue Viability* 23: 13-23.
5. Levy, A., Kopplin, K., Gefen, A., (2014). "Computer simulations of efficacy of air-cell-based cushions in protecting against reoccurrence of pressure ulcers." *Journal of Rehabilitation Research & Development* 51(8):1297-1310.
6. Levy, A., et al, Simulations of skin and subcutaneous tissue loading in the buttocks while regaining weight-bearing after a push-up in wheelchair users. *Journal of the Mechanical Behavior of Biomedical Materials* (2013), <http://dx.doi.org/10.1016/j.jmbbm.2013.04.015>
7. www.npuap.org
8. Schofield R, Poerter-Armstrong A, and Stinson M, Reviewing the Literature on the Effectiveness of Pressure Relieving Movements. *Nursing Research and Practice*, 2013. p. 1-31.
9. Sonenblum SE, Springle S, Maurer CL, Use of power tilt systems in everyday life. *Disability and Rehabilitation: Assistive Technology*, 2009. 4(1): p. 24-30.
10. <http://en.wikipedia.org/wiki/Research>

IC69: Sip'n Puff: A Thing of the Past?

David J Kreutz, PT, ATP

Chris Maurer, MPT, ATP

Mark Partridge, RRTS

Many alternative drive options exist for people who are not physically capable of using a joystick to control a power wheelchair. Some common examples include a 3 or 5 switch head array, chin control, RIM control, and single switch scanner. A sometimes forgotten option is sip'n puff! Why has sip 'n puff moved to the end of the list? The purpose of this presentation is to attempt to demystify sip 'n puff and present the pros and cons of its use as a viable alternative drive option.

Sip and puff systems have been around for a long time and they definitely have been coined "old school". They have gotten a bad rap because people don't want a "straw" in their face. However, there are numerous advantages to a sip'n puff system.

- 1. Cost:** For an alternative drive system, it is one of the cheapest options available. On average, a sip 'n puff system costs approximately \$1600-2000 US. A head array system can range from \$4200-4600. A head array/ sip'n puff combination can climb to \$5500! A RIM control can cost \$3050 which is in the range of a mini proportional joystick that is used as a chin control (that doesn't include the mounting hardware). Overall, sip 'n puff systems can be \$1500 cheaper than the next most functional option.
- 2. Immediate use:** A nice benefit to sip 'n puff systems for the clients with recent traumatic spinal cord injury or other diagnoses with very limited movement who are receiving initial rehab is that they can be set up quickly. A newly injured client who is able to make a seal around the straw and create positive pressure can be trained on how to drive a power chair and achieve independence in mobility and weight shifts soon after admission. With some of the other alternative drive options, range of motion and sufficient strength to be able to control the necessary cervical motions may have to be achieved prior to being able to begin or achieve independence with mobility.
- 3. Position independent:** The most valuable benefit to the sip 'n puff system is that they are not position dependent. The straw can be positioned to wherever the client is positioned in the chair that particular day/time without any tools, contrary to a head array or chin /RIM control. In addition, if the client has contact with the straw, it will move with the client if he/she spasms in the chair or loses positioning through weight shifts or other reasons throughout the day. The type of head wear someone uses does not affect sip 'n puff as it does a head control type system either in distance from the switches or the ability of proximity switches to activate (?).

- 4. Least amount of switch sites:** All control is able to be performed through the sip'n puff straw if necessary and not have to use an external switch site. A fiber optic switch attached to the straw can be the remote stop switch which will stop the chair if the straw is removed from the pt's reach in the latch drive for safety so an additional switch site is not needed as the other systems typically require.
- 5. Not affected by uneven terrain:** Sip 'n puff use is independent of head movement, so clients are able to continue driving the chair safely over uneven terrain even if head is moving or spasticity is elicited.

There are some disadvantages to the sip'n puff as there are to any alternative drive system. Some specific to sip 'n puff include:

- 1. Straw in mouth:** Yes, there is a straw near your mouth.
- 2. Maintenance:** Have to clean the saliva trap and replace the straw/tubing routinely
- 3. Need to have teeth:** Impairs ability for lip closure. In addition, oral motor control to obtain seal around the straw needs to be present.
- 4. Cognitive demand:** Memory and ability to follow multi-step commands.

Mounting and Setup of the sip and puff system prior to operation.

1. There are several options for mounting sip and puff straws to the wheelchair. Options for mounting include a swing away bracket on the headrest that allows right or left mount, a vertical mount off the backrest with a pin style mount to prevent rotation.
2. The flexible straws come in varying degrees of flexibility from nearly rigid metal extensions to snap together modular hose with replaceable liners. The replaceable liners allow the inner tubing to be replaced for hygiene. The small extensions that the client actually sips and puffs into come in an array of colors. The tips of the straw have a small lip used for positioning the straw in one's mouth. The tip of the straw has numerous small slits to allow the air to move in and out but to block larger objects.
3. Saliva trap/ filter: A saliva trap or filter can be installed into the tubing running from the straw to the switch device. Individuals that produce secretions that collect in the tubing should be provided a saliva trap. The saliva trap prevents fluids from building up in the tubing. A build-up of fluid in the tubing can result in inadvertent activation of a forward command. A saliva trap is a sealed tube that allow the secretions to settle to the bottom of the tube without effecting the pressure within the tubing. For individuals do not produce secretions should just have a small in-line filter placed in the tube. Saliva traps can be cleaned or replaced. Filter should be replaced when the sip and puff tubing is replaced.
4. Tubing length and tubing diameter: The tubing length should be cut to the appropriate length. Tubing should be long enough to allow a small loop in the tube before connecting to the display or sip and puff module. This small loop allows secretions to collect without harming the electronics. Excess tubing should be trimmed. Manufacturers use different tubing diameters

5. Reset/mode/emergency stop switches: A mechanical stop switch is needed for several purposes. This switch can be used to stop the chair in an emergency. For example if the user loses the straw. The switch can also act as a reset mode switch. This switch is required with sip and puff systems. The electronics will not allow the chair to be driven without having a reset mode switch plugged into the chair. Some manufactures allow this switch to also turn the chair on/off by maintaining contact with this switch for a longer period of time. Multiple different types of switches can be used as reset mode switch. Examples might include an egg switch, microlite, tongue switch. Electrical switches used with sip and puff include fiber optic or proximity switches. Placement of the switch will be determined by the user's function and most consistent activation site. It is imperative that the user be able to access and activate the reset/mode/emergency stop switch prior to being taught to drive the wheelchair.
4. Latched time out: Period of time before the chair will stop driving if a command is not made by the user. This programming feature is only available on Permobil, Quantum, and Quickie products. Latched time out will stop the wheelchair after a given period of time unless the client another command within the allotted time. The time period can be adjusted from 10 seconds to 250 seconds. When the user gives a forward command and latches the system in forward drive the timer begins. If another command such as a turn or forward speed increase is not given within the latched time out setting then the chair will stop. It is important to educate the client regarding latched time out and to adjust it appropriately. This feature cannot be turned off. Therefor the client must know that his/her chair may stop driving if he/she does not perform a command within the time period. This is a safety feature on certain chairs.
5. Speed settings for initial set up

Prior to actually having the client drive or utilize the seating system on the chair the clinician/supplier should program and drive the chair. Written instructions for the end user should be provided so that the user can relay this information to his/her caregivers. These instructions will vary depending on the manufacturer and programming of the wheelchair. Programming considerations are listed below.

Programming features critical to driving with a sip and puff system:

1. Motor balance/steer correct: The supplier and therapist should drive the chair prior to getting the client in the chair to insure that the wheelchair drives in a straight line. A chair that does not drive in a straight line will make it very challenging to drive. It will require frequent course corrections by the client.
2. Tracking systems: True Trac-Invacare, ESP- Permobil, Accutrac-Quantum: These are tracking systems that maintain a straight course despite changes in the environment such as side slopes, cracks, thresholds, etc. While not absolutely essential, this programming feature significantly improves the efficiency and control of the wheelchair.
3. Latched Drive: Latched driving is similar to cruise control on a vehicle. Once a forward command is given the wheelchair will maintain a forward direction until given a hard sip (reverse/stop command). Latched driving allows the user to course correct and turn without coming to a stop. Typically only forward direction is latched, but manufacturers do allow for both forward and reverse directions to be latched. Options for latch speed include: 1 speed; speed variation up and down including step, 3spd, and 5 spd; and finally cruise control. These latched options beyond 1 speed allow the client to increase or decrease the speed of the chair while driving. This significantly improves the clients ability to maneuver the wheelchair in tight spaces, decrease and increase the speed as he/she enters/exists a turn, and change the speed due to variations in the terrain. Without latch drive the client would have to blow continuously to drive forward and have to come to a complete stop before turning. It is latched driving that allows sip and puff drive to approximate proportional driving control.

Training progression:

- The client should be taken to a large open area.
- Calibrate for user: (visual feedback vs auditory feedback)
- Insure that the client can activate the reset mode switch.
- Educate the client how to access all of the various modes of operation: drive, seat functions, speed adjust, etc.
- Instructions for 4 switch sip and puff commands:
 - Hard puff –forward
 - Hard sip- stop/reverse
- Initiate right and left turns and work towards maintaining the turn by having the client use consistent pressure.
- Initiate latched forward driving and stopping.
- Work on steering while driving forward.
- Initiate reverse drive
- Program drives differently for environment and allow client to progress from 1 spd to varying speeds with up and down speed control and eventually to latched cruise control.

IC70: Challenges and Solutions in Seating for Infants and Toddlers

Janice Hunt Herman, PT

Seating and positioning is often overlooked in multiply disabled children during the period of Early Intervention (birth to 3 years of age). In part this occurs because parents are overwhelmed as they struggle to cope with serious medical issues. Positioning becomes low priority compared to breathing and nutrition. The medical team may be unaware of the benefits of good positioning or not know who to refer to. Equipment for seating very small children is sparse, and very rarely available for trials. Even if a device is recommended, insurance may be reluctant to fund it. Seating and positioning for young children is a service that has fallen through the cracks for too long.

An ever growing number of therapists have recognized that 24 hour postural management is a critical component of early intervention services. Growth and development proceeds at its most rapid pace during the first few years of life. Skills are developed simultaneously in multiple domains including physical, motor, sensory, social, and cognitive. Each new skill builds on one another, and to fail in one domain will negatively impact the others. So if development lags in postural control, such as sitting or standing, intervention is needed, and that intervention might include use of a supportive device.

Some therapists are reluctant to offer postural support devices for sitting. They question whether it is appropriate to use a device to sit a non-sitting child. They agree that developmental milestones should proceed in a specific order and that skills build on each other. The concern is that providing a seating system will allow the child to skip this milestone, thus promoting problems later in development. Too much 'external' support could make the child lazy and less inclined to develop the 'internal' support of strong bones and muscles. Others contend that the parent's arms are the best sitting support a child could have. But what happens when those arms are not available?

In support of providing early sitting devices, therapists contend that we've been doing it for years with towel rolls and pillows; Why not a device that applies forces in a specific, consistent, and therapeutic way? If we don't provide help, parents will simply resort to commercial seats and other available generic equipment that can be more harm than good for a multiply disabled child whose challenges and needs are complex and unique. Research evidence shows that delaying sitting will unnecessarily delay progress in other domains. Supportive devices are provided for wheeled mobility, standing, and walking as soon as age appropriate. Why not sitting?

Properly designed seating support devices can and should be designed to promote trunk development, not delay it. The seating goals need to change as the child progresses through the stages of unstable sitting propped on arms, to

sitting statically balanced but vulnerable to perturbation, to dynamically balanced sitting while reaching and rotating. In biomechanics, 'stability' is defined as the capacity of an object to return to equilibrium or to its original position after being displaced. Stability actually involves movement. So stable sitting, the child's goal, involves moving in and out of the optimum position. As seating therapists we often focus so intently on the optimum 'frozen in place' posture that we neglect to encourage, or even allow for, body movement.

Research has identified many benefits of sitting. Obvious benefits include face-to-face interaction, communication, and social skills. With both arms free, the child can manipulate bigger heavier toys, improving arm reach and crossing midline. Reaching improves co-contraction, coordination and strength in the shoulder girdle, neck and upper back. As the child looks around, vision and eye-hand coordination improve. The child becomes aware of spatial dimension, object permanence, and many other cognitive advances. Holding the trunk erect optimizes breathing, digestion, and swallowing. No child should be denied these developmental opportunities simply because seating support was not available to them.

Guidelines for seating the very young child should include:

1. **DEVELOPMENTALLY APPROPRIATE:** The child should be clearly delayed in motor development, not just a late bloomer. Provide the minimum support needed to allow the child to be successful. Over supporting can be counter-productive by promoting laziness. It also adds weight and complexity causing parents to abandon using it.
2. **PROMOTE FUNCTION:** The goal(s) should be defined in terms of a functional task that depends on sitting posture. What developmental opportunity would be denied if seating is NOT provided? Incorporate parents, caregivers and medical team when setting goals. Design/select the device with the goal in mind.
3. **TASK SPECIFIC:** The seating device should be used only for specific therapeutic activities, such as, feeding, manipulating toys/objects, interacting with others. It is not for lounging or napping. The seating support may need to fit into an existing base (wheelchair, stroller, floor seat, highchair). To promote tabletop activities, the seat may need a tray or table fitted to the proper height.
4. **TIME LIMITED:** The seating device should be used daily for short periods interspersed with other postures including tummy time (prone), rolling, rocking, and in loving arms.

Although differences between infant and adult anatomy and biomechanics is well known, very little has been published on best practices to properly support sitting posture in infants and small children. Techniques must be modified for measurements, simulation, and intervention. The mat exam needs to address anatomical, neurological, reflex, sensory and motor control differences because infants are really not miniature adults. Some issues to consider include:

1. At birth the pelvis is mostly cartilage. In particular, the ASIS (anterior superior iliac spine), ITs (ischial tuberosities), and other seating landmarks are not bone yet. So straps (seat belts) designed to hook under

- the ASIS are ineffective, especially when the pelvis is wrapped in fat tissue and a thick diaper. Nonetheless, just like adults, the pelvis is the base of support and critical to upright sitting. The pelvis should be well supported on all sides to prevent anterior/posterior tilting. A laterally tilted pelvis may create a spinal C-curve or torso lean.
2. The spine is a single kyphotic curve in infancy (0-3 months). Cervical lordosis develops at 3-6 months as baby lifts her face to experience the environment. Lumbar lordosis develops at 18-24 months as a result of vertical weight bearing as in sitting and later standing. The therapist must determine which, if any, of these spinal curves have developed, and then respect them when applying external forces with a seating or positioning device.
 3. The thorax of an infant is so short that it can be difficult to use lateral support pads. The position and thickness must be adjusted to allow the arms to come forward and get hands to midline. A chest strap/harness may be effective in holding the trunk against the seat back, but it should not limit the child's ability to lean forward to prop on his forearms as this weight-bearing strengthens the shoulder girdle.
 4. Hip joints are unstable at birth which allows them to wrap around the torso in utero. Although shallow for the first year, the pelvic acetabulum deepens as baby kicks, crawls and eventually stands. The femoral head also changes angle and rotates during the first year. In sitting, the position of head in the acetabulum is defined by hip abduction. The optimum abduction has yet to be determined by scientific evidence. Always ask about hip subluxation, dysplasia, and dislocation before positioning any infant or young child.
 5. Primitive reflexes may still dominate an infant's posture, particularly ATNR (asymmetrical tonic neck reflex), TLR (tonic labyrinthine reflex), and STNR (symmetrical tonic neck reflex). When present, these should be accommodated.
 6. Medically compromised babies may have low, high, or mixed muscle tone. Tone may increase when the child is stressed or attempting to move. The child may arch his torso and head backwards while thrusting his hips forward and straightening his legs. He may bang his head or flip the seat over backwards. Techniques to inhibit this full body extensor synergy/pattern should be coupled with techniques to protect the child from injury.
 7. A newborn's head is very large for her body size and increases 30% during the first year. The heavy weight of the head combined with the short lever arm of the neck and torso may allow gravity to overpower, pulling the head down. Head support must carefully consider protecting the neck without limiting baby's ability to practice moving her own head. Supports might be snug and very confining to hold the head for certain activities, and then more distant to simply prompt her to lift her head back up. Tilting the seating system to align the head just past the line of gravity may help, but if overdone the child may be unable to actively pull her head forward.
 8. Supporting a very small child's feet requires special consideration. Infants may be sensitive to touch or pressure on the soles, resulting in a stepping response with leg extension. Even if not standing, ask if foot or ankle orthotics are used as this will change the leg length. Before determining placement of the footrest, check how much knee flexion is available because even

young children have tight hamstrings.

9. A child's sensory system will determine his tolerance to tactile (touch) and temperature. A contoured system may offer the needed support but not be tolerated by a child who overheats easily or hates being swaddled.
10. Infants are poor communicators, so feedback regarding their comfort and sensory tolerance of the device is non-specific. Ask parents what that cry means. Falling asleep in the device should not be mistaken as contentment. The child may simply be exhausted.
11. Assessing an infant at a single appointment or 'moment in time' is just one snapshot, and apt to be invalid. Ask parents if the child's presentation today is typical for him. Frequent modifications and 'tweaks' should be expected with this population because they grow rapidly and new skills develop.

Clinical expertise in seating for early intervention is expanding. Although finding appropriate and affordable commercial equipment is improving, creative do-it-yourself equipment solutions often will work just as well. Consider making contoured shapes with liquid foam or foam blocks that can be carved by hand or with a high end Computer Numeric Control carver (CNC router/mill). Stable bases can be built using triply cardboard, ABS plastic, or plywood. Small components can be made with a 3-D printer. To find support, training, and tools to share, look into 'MakerSpace' workrooms that are popular in many communities. Enlist the help of service organizations or charities for labor and supplies. At many colleges Rehabilitation Engineering and Bio-Engineering students are required to complete a design project for the disabled population. Challenge them to make your real life solutions.

References

1. Chung, J., Evans, J., Lee, C., Lee, J., Rabbani, Y., Roxborough, L., & Harris, S. R. (2008). Effectiveness of Adaptive Seating on Sitting Posture and Postural Control in Children with Cerebral Palsy. *Pediatric Physical Therapy*, 20(4), 303-317. doi:10.1097/pep.0b013e31818b7bdd
2. Hadders-Algra, M. (2013). Typical and atypical development of reaching and postural control in infancy. *Dev Med Child Neurol Developmental Medicine & Child Neurology*, 55, 5-8. doi:10.1111/dmcn.12298
3. Hedberg, Å, Carlberg, E. B., Forssberg, H., & Hadders-Algra, M. (2005). Development of postural adjustments in sitting position during the first half year of life. *Dev Med Child Neurol Developmental Medicine & Child Neurology*, 47(5), 312-320. doi:10.1017/s0012162205000605
4. Groot, L. D., Hopkins, B., & Touwen, B. (1995). Muscle power, sitting unsupported and trunk rotation in pre-term infants. *Early Human Development*, 43(1), 37-46. doi:10.1016/0378-3782(95)01661-1
5. Heide, J. C., Otten, B., Eykern, L. A., & Hadders-Algra, M. (2003). Development of postural adjustments during reaching in sitting children. *Exp Brain Res Experimental Brain Research*, 151(1), 32-45. doi:10.1007/s00221-003-1451-3
6. Washington, K., Shumway-Cook, A., Price, R., Ciol, M., & Kartin, D. (2004). Muscle responses to seated perturbations for typically developing infants and those at risk for motor delays. *Dev Med Child Neurol Developmental Medicine & Child Neurology*, 46(10). doi:10.1017/s0012162204001148

IC71: Creating Partnerships Among Clinicians and Engineering Programs

Lisa Kenyon, PT, DPT, PhD, PCS
John Farris, PhD

Background:

Therapists often have great ideas for specific customized, adaptive equipment that may help their patients but may lack the technical expertise needed to actually design and create such equipment. The Accreditation Board for Engineering and Technology (ABET) requires engineering schools to demonstrate that their graduates are able to complete a design project under realistic constraints (ABET, 2016). Therefore, engineering education programs often have requirements related to student completion of design projects and yet may not always know what specific customized, adaptive equipment would be beneficial. This paper provides an overview of ways in which therapists can partner with engineering education programs at their local colleges or universities to create customized, adaptive equipment designed to meet the needs of individual patients.

Overview:

Partnering with engineering education programs and sponsoring a specific project can create a win-win situation for therapists, patients, engineering faculty, and engineering students. Such partnerships may offer therapists and patients access to customized adaptive equipment. Partnerships between local physical and occupational therapists and the engineering education program at Grand Valley State University have resulted in a wide variety of customized, adaptive equipment for use in clinics, patient homes, and in research. Examples include items such as the Power Wheelchair Trainer (Kenyon, Farris, Brockway, Hannum, & Proctor, 2015) and the Play and Mobility Device (Kenyon et al., 2016) that provide an alternative means by which to achieve power mobility training for children who have multiple, severe disabilities. Additional examples will be highlighted at the conference.

Working with therapists to address real-world clinical problems provides engineering students with an interprofessional opportunity focused on meaningful design experiences. Such projects provide engineering students opportunities to practice and refine skills across multiple areas. In fact, communication and professional skills may be better highlighted in projects that are sponsored by non-engineers. Projects focused on creating customized, adaptive equipment for a specific patient may also allow engineering students to interact with patients and families and therefore gain experiences and knowledge beyond the technical aspects of engineering design process. For example, engineering students involved in therapist sponsored

projects pertaining to the Play and Mobility Device appeared gain knowledge not only about the needs of children with disabilities but also about the capabilities of these children (Kenyon & Farris, 2015).

Keys To Successful Partnerships

Successful partnerships are built upon open and direct communication, realistic expectations, and breaking down professional barriers. Professional “lingo” on the part of both therapists and engineers can be an obstacle to effective communication. All involved in the project must be willing to step out of their professional silos and focus on understanding the problem and being open to different concepts and ideas. All partners in the project must also be willing and able to devote extra time to understanding and appreciating the viewpoints of others on the project. Potential sources of funding to help cover the cost of materials such used to create customized adaptive equipment include grants through the National Science Foundation.

Conclusion

With foresight and intention, partnerships between therapists and engineering education programs can be rewarding and beneficial for all those involved.

References:

1. Accreditation Board for Engineering and Technology. (2016 10 16). Criteria for accrediting engineering programs: effective for reviews during the 2016-2017 accreditation cycle. Retrieved at: <http://www.abet.org/wp-content/uploads/2015/10/E001-16-17-EAC-Criteria-10-20-15.pdf>.
2. Green, M.G., D.J. Jensen, C. C. Seepersad, & Wood, K.L. (2009). Design for frontier contexts: classroom assessment of a new design methodology with humanitarian applications. *International Journal of Engineering Education*, 25(5):1029-1045
3. Goldberg, M.R., & Pearlman, J.L. (2013). Best practices for team-based assistive technology design courses. *Annals of Biomedical Engineering*, 41(9):1880-1888.
4. Kenyon, L.K., & Farris, J.P. (2015) Engineering hope: enhancing quality of life through design education. Proceedings from the 2015 American Society of Engineering Educators Annual Conference & Exposition. Paper ID #11546.
5. Kenyon, L.K., Farris, J., Brockway, K., Hannum, N., & Proctor K. (2015). Promoting self-exploration and function through an individualized power mobility training program. *Pediatric Physical Therapy*, 27(2):200-206.
6. Kenyon, L.K., Farris, J.P., Gallagher, C., Hammond, L., Webster, L.M., & Aldrich, N.J. (2016). Power mobility training for young children with multiple, severe impairments: a case series. *Physical and Occupational Therapy in Pediatrics*, 1-16. doi:10.3109/01942638.2015.1108380.

Correspondence

Please address correspondence to:
Dr. Farris at the following e-mail address:
farrisj@gvvsu.edu

We (**Lisa Kenyon and John Farris**) do not have any conflicts of interest to disclose. Specially, none of the authors have an affiliation (financial or otherwise) with an equipment, medical device, or communications organization.

IC72: Back to the “Ideal” Ultralight Manual Wheelchair

Rosemarie Cooper, MPT, ATP

Rory A. Cooper, PhD

Bryan. M. McCormick, M.S., CRC

Marshall Lee Tempest

Abstract:

Despite very challenging, very frustrating and at times disheartening changes related to provision of seating and mobility devices in the US we believe that we can still have a realistic chance to provide appropriate equipment for our end users; however, funding , although very important, will not be the focus of this session, as we seek to find our way back to the “ ideal” in ultralight manual wheelchair provision and set up, as it was done in the 90’s, when acute rehab stays for patients with SCI were at least 6 months and therapy programs extended beyond basic ADLs , and included training of advanced mobility skills for independent function outside the home as well as recreational mobility skills to enhance quality of life for the individual; unheard of in today’s acute rehabilitation environment, given the short 4-6 weeks average rehab stays and

Medicare’s “in-the-home-only” funding policy. Despite very challenging, very frustrating and at times disheartening changes related to provision of seating and mobility devices in the US we believe that we can still have a realistic chance to provide appropriate equipment for our end users; however, funding , although very important, will not be the focus of this session, as we seek to find our way back to the “ ideal” in ultralight manual wheelchair provision and set up, as it was done in the 90’s, when acute rehab stays for patients with SCI were at least 6 months and therapy programs extended beyond basic ADLs , and included training of advanced mobility skills for independent function outside the home as well as recreational mobility skills to enhance quality of life for the individual; unheard of in today’s acute rehabilitation environment, given the short 4-6 weeks average rehab stays and Medicare’s “in-the-home-only” funding policy.

In this session we would like to share with the audience the approach we have taken on the way back to the “ideal” and the areas that guided its path and plan to talk about the current state of acute SCI Inpatient Rehabilitation (Lee Tempest), present the role of SCI peer support groups (Bryan McCormick) ,share findings applied from wheelchair sports (Rory A. Cooper) and focus on the final fitting and training of ultralite manual wheelchairs as part of the AT-service delivery process (Rosemarie Cooper) .

Session Description:

In this session we would like to share with the audience the approach we have taken on the way back to the “ideal” and the areas that guided its path:

1. Current state of acute SCI Inpatient Rehabilitation (Lee Tempest) as short stays in rehab has made it challenging to properly asses patients. Focusing on what their home environment is inside and outside to give them a chance to work well with their wheelchair in their daily environment. Also focusing on their activity level before they have come to rehab attempting to set them up the best you can in a short time frame to hopefully allow them to integrate back into the community without having to struggle with a wheelchair that is too bulky or too big.
2. Role of SCI peer support groups (Bryan McCormick) -is instrumental in helping wheelchair users understand what a properly fitting wheelchair looks like. Wheelchair users are often not educated sufficiently about properly fitting wheelchairs when they are undergoing rehabilitation. After acute rehabilitation, wheelchair users may not trust assistive technology providers to fit them properly. Peer mentoring can instill trust and help wheelchair users learn about a wheelchair should fit to improve access to one’s community.
3. Brief overview of the history and development of ultralight manual wheelchairs and share findings applied from wheelchair sports (Rory A Cooper)
4. Role of AT- Service Delivery System (Rosemarie Cooper) will focus on the importance of the final fitting and training on ultralight manual wheelchairs, as the failure to invest in the time and the quality of training will cause inappropriate use of the technology, which may cause harm and injuries to the end user and will provide third party payers added reason to cut funding for existing technology.

Outcome Learning Objectives:

Upon completion of this session, attendees will be able to:

1. Identify three important areas that will influence the outcome of manual wheelchair acceptance and prescription during acute SCI Inpatient Rehabilitation.
2. Identify the influence and effect of SCI peer support groups on the acceptance of appropriate wheelchair fit, usage and skills-sets.
3. Identify the four steps used during the final fitting process and their effect on:
 - a. Seating / Positioning
 - b. COG distribution
 - c. Propulsion Biomechanics,
 - d. Wheelie skills.

References:

1. Consortium for Spinal Cord Medicine:-Clinical Practice Guidelines for Health Professionals “Preservation of Upper Limb Function Following Spinal Cord Injury” ; Paralyzed Veterans of America; www.pva.org
2. Cooper RA, Cooper RM, What’s the Right Ultralight?, PN, pp. 30-31, Vol. 64, No. 7, July 2010
3. Cooper RA, Cooper RM, Ready ... Set ... Push, PN, pp. 26-29, Vol. 67, No. 3, March 2013.
4. Cooper RA, Cooper RM, Save Your Shoulders, Sports ‘N Spokes, pp. 49-51, Vol. 39, No. 4, July 2013.
5. Cooper RM, Cooper RA, Proper Set-Up and Training to Optimize Self-Propulsion of Manual Wheelchairs, Directions, pp. 44-49, Vol. 3, 2015.

PS9.1: Using Wearable Sensors to Track Upper Extremity Motion in Rehabilitation: A Literature Review

Akhila Veerubhotla, MS
Dan Ding, PhD

Introduction:

With the advancement in technology, wearable sensors are increasingly getting smaller, lighter and cheaper. Wearable sensors are being used to replace traditionally used optical based systems for observing and analyzing movement over time. Inertial Measurement Units (IMUs) are a type of wearable sensors, which consist of accelerometer, gyroscope and magnetometer. They are used to provide information relating to movement in terms of acceleration, angular velocity, rotation and orientation of each segment of the body. Though IMUs are largely being used for gait analysis, their use for upper extremity movement analysis is currently slowly expanding [1].

Most of the activities of daily living including bathing, toileting, dressing, feeding, cooking and lifting objects involve complex movements of the upper extremity [2]. Helping people to perform these activities of daily living independently is one of the major aims of rehabilitation. The use of IMU sensors is increasing in rehabilitation because these sensors have a potential for continuous monitoring and studying movement in one's natural environment. This review aims to provide information on the validity of IMU sensors for upper extremity tracking and reviews various applications of these sensors in rehabilitation.

Validity of IMU sensors for upper extremity tracking:

Upper extremity movement consists of a chain of segments moving together. Therefore, in order to study upper extremity movement, IMU sensors are attached to each segment (Upper arm, lower arm, forearm, spine, chest, wrist) depending on the joints under observation. Complex algorithms are designed to obtain joint angles from IMU data and compared with commercially available optical measurement systems, which are currently the gold standard for such measures. Validation studies generally use commercially available IMU sensors along with new and efficient algorithms to estimate joint angles [3]-[10]. But, validation studies for upper extremity tracking are currently in laboratory setting, for short duration of time (a few seconds to a few minutes) involving simple planar movement of the upper extremity.

Yujin Jung et. al. [3] tracked upper body movement for flexion at shoulder (raising both arms above the head), flexion at elbow (bending arm with forearm facing upwards while upper arm is fixed to the body) and lateral bending at the waist. IMU sensors were placed at the two upper arms, two lower arms, torso and pelvis. An inverse kinematic algorithm was used to estimate joint orientation from IMU sensors (make and model not provided). The joint estimates from IMU sensors were compared to the joint estimates obtained commercially available motion capture system (Hawk Digital Real Time System). They found that along two (y and z axes) of the three axes, the difference in joint orientation estimation between the IMU model and the motion capture system was less than 5 cms though the third axes (x axis) estimates had greater differences. Bryan Kirking et.al. [4] evaluated the feasibility of using IMU sensors (APDM Inc., OR, USA) to track joint angles for elbow flexion/extension at shoulder, elbow and wrist, shoulder internal/external rotation, forearm pronation/supination and wrist twist. They used an enhanced Unscented Kalman Filter to estimate joint angles from the IMU sensors placed on a robotic arm (Epson Robots, California, USA). For all six angles they found root mean square error of 3 degrees or less between robotic arm and IMU angles. Huiyu Zhou et.al. [5] used a quality-constrained optimization technique to track upper and lower arms of human subjects using IMU sensors (Xsens, Netherlands). They estimated Euler angles for object reaching, shoulder shrugging and forearm rotation tasks and found a root mean square error of 2.5 degrees to 4.8 degrees between the angles derived from IMU compared to those obtained from commercial optical tracking system. Mahmoud El-Gohary and James McNames [6] combined kinematic methods with state space methods to estimate joint angles from the IMU sensors (APDM Inc., OR, USA). They compared angles from IMU sensors to angles obtained from an optical tracker and found on an average, the root mean square error to be less than 8 degrees for all shoulder and elbow angles. Morrow M MB et.al. [7] validated IMU sensors (APDM Inc., OR, USA) for shoulder elevation, elbow flexion, trunk flexion/extension and neck flexion/extension against an optical motion capture system. They found that the shoulder elevation and elbow flexion angles were accurate to about 7 and 8 degrees respectively, neck and trunk flexion/extension angles were accurate to within 3 and 2 degrees respectively. They found that larger the angles the IMU estimates were less accurate.

The results from these studies show that upper extremity joint angle estimation from IMU sensors is not very accurate yet. Also, validation studies for activities of daily living in 3D space are required to know the feasibility of IMU use in day-to-day living. Though upper extremity joint angle estimation using IMU is not very accurate yet, IMUs can still be used for various applications in rehabilitation that do not require (accurate) joint angle estimation.

Applications in Rehabilitation:

A. Predicting outcome measures: Micheal Brogioli et.al [2] used IMU sensors (ReSense, designed by Leuenberger and Gassert [11]) to estimate the intensity of upper extremity use during manual wheelchair propulsion and limb use laterality for people with SCI. They correlated intensity of upper extremity use and limb use laterality with clinical assessment

scores of Independence (measured using SCIM III (Spinal Cord Independence Measure) questionnaire). Subjects (inpatients at SCI centers) were asked to put on IMU sensors (on both wrists, chest and wheel of wheelchair) and perform unilateral activities of the GRASSP QtG (to help distinguish limb laterality) and then continue with their daily inpatient schedule for the day while wearing the sensors for 3-6 hours. Machine-learning algorithms were used to distinguish between active and passive propulsion and obtain kinematic estimates of wheelchair movement (ex:distance) based on IMU data. They found that more intense upper extremity movements during self-propulsion (calculated from IMU data) positively correlated ($p < 0.05$, $r = 0.64$) to independence (SCIM III subscore). Micheal Brogioli et.al. [12] also performed multi day recordings in home-environment of subjects with SCI and demonstrated that intensity of upper extremity use (calculated from IMU sensors) correlated with measures of function and independence (obtained from SCIM III subscores) in people with spinal cord injury.

B. Rehabilitation aid: Camilla Pierella et. al. [13] developed a body machine interface by mapping the movement of the upper body (obtained from IMU sensors (YEI technology, Ohio, USA) placed on the shoulders) to the movement of a cursor on a computer using principal component analysis (PCA). They performed a case study with a SCI subject who had impaired movement on one side of the body. The main aim of the body machine interface rehabilitative aid was to restore symmetrical use on both sides of the body. The subject was encouraged to type text and play games by moving the cursor on the computer screen using both upper extremities. The mapping between the upper body movement and the cursor was modified gradually so that the user had to exercise their impaired limb. After a two weeks of practice sessions they found that the subject had restored symmetrical use on both sides of the body.

C. Upper extremity tracking during activities of daily living: Alexander W. Hooke et.al. [14] used IMU sensors to study joint kinematics during wheelchair propulsion. They validated IMU sensors during propulsion task, which is an activity of daily living involving three-dimensional motion of the upper extremities. 4 IMU sensors were attached (one each on the upper arm, lower arm, hand and chest) to the subject and three dimensional joint angles of the shoulder (flexion/extension, ab/adduction, int/ext rotation), elbow (flexion/extension, pro/supination, carry) and wrist (flexion/extension, ab/adduction) were calculated. The normalized propulsion cycle joint angles calculated from the IMU sensor showed a root mean square error of about 4 -5 degrees at each joint for all angles. Nuno Oliveira et.al. [15] studied elbow kinematics along with push rim forces during wheelchair propulsion. They calculated elbow joint angles from IMU sensors and found that the elbow angles were lower than those reported in other studies that used optical tracking for elbow joint. But they believe that the IMU system with its advantage of portability held promise for such applications once joint estimation algorithms are improved.

Discussion:

In rehabilitation, recovery is an ongoing process and therefore monitoring of functional movement even after discharge from the hospital is required. But, currently there are no instrumented assessment equipment that can help and assess the rehabilitative process at an individual's home [5]. IMUs with their various advantages may be the solution to this problem. The accuracy, stability and data logging abilities of IMUs are increasing [4] with the development of new algorithms. Unlike the optical tracking systems, IMUs do not need to be in the line of sight to record measurements. Moreover, IMUs have the advantage of being lightweight and portable, making them an attractive option for use in rehabilitation. IMUs can be used as part of diagnostic and assessment tools in rehabilitation as discussed in this review. Although IMUs may be a viable option for some applications in rehabilitation, there is a need for improvement before their scope of use may be increased.

Most of the studies in this review were found to use commercially available sensors that cost about \$1000 each or more. Though these sensors cost much less than the commercially available optical tracking systems and have the added advantage of being portable, validating sensors that are much cheaper may be beneficial. It is also noted that most validating studies in this review involved performing tasks that involve planar movements that do not fully replicate movement of upper extremities in every day use. Also, tasks performed in these studies lasted for a short duration of time. Since upper extremities are used for a number of activities of daily living and are therefore in for a longer time, it is necessary to have study procedures that replicate real life movements.

In conclusion, this review finds that IMU sensors have the potential to be used in upper extremity rehabilitation though algorithms used for estimating joint angles may require improvement. Also, there is a requirement for validating the use of IMU sensors during activities of daily living and for longer durations of time. It is also noted that with improvement in joint angle measurements using IMU sensors, these sensors may become open to a wider spectrum of applications in upper extremity rehabilitation.

References:

1. Pérez, R., Costa, Ú., Torrent, M., Solana, J., Opisso, E., Cáceres, C., ... & Gómez, E. J. (2010). Upper limb portable motion analysis system based on inertial technology for neurorehabilitation purposes. *Sensors*, 10(12), 10733-10751.
2. Brogioli, M., Popp, W. L., Albisser, U., Brust, A. K., Frotzler, A., Gassert, R., ... & Starkey, M. L. (2016). Novel Sensor Technology to Assess Independence and Limb-Use Laterality in Cervical Spinal Cord Injury. *Journal of neurotrauma*.
3. Jung, Y., Kang, D., & Kim, J. (2010, December). Upper body motion tracking with inertial sensors. In *Robotics and Biomimetics (ROBIO), 2010 IEEE International Conference on* (pp. 1746-1751). IEEE.
4. Kirking, B., El-Gohary, M., & Kwon, Y. W. (2016). The feasibility of shoulder motion tracking during activities of daily living using inertial measurement units. *Bone Joint J*, 98(SUPP 8), 107-107.
5. Zhou, H., Stone, T., Hu, H., & Harris, N. (2008). Use of multiple wearable inertial sensors in upper limb motion tracking. *Medical engineering & physics*, 30(1), 123-133.
6. El-Gohary, M., & McNames, J. (2012). Shoulder and elbow joint angle tracking with inertial sensors. *IEEE transactions on biomedical engineering*, 59(9), 2635-2641.
7. Morrow, M. M., Lowndes, B., Fortune, E., Kaufman, K. R., & Hallbeck, S. (2016). Validation of Inertial Measurement Units for Upper Body Kinematics. *Journal of Applied Biomechanics*, 1-19.
8. Theobald, P. S., Jones, M. D., & Williams, J. M. (2012). Do inertial sensors represent a viable method to reliably measure cervical spine range of motion?. *Manual therapy*, 17(1), 92-96.
9. Van Der Slikke, R. M. A., Berger, M. A. M., Bregman, D. J. J., Lagerberg, A. H., & Veeger, H. E. J. (2015). Opportunities for measuring wheelchair kinematics in match settings; reliability of a three inertial sensor configuration. *Journal of biomechanics*, 48(12), 3398-3405.
10. Lin, J. F. (2012). Human pose recovery using wireless inertial measurement units. *Physiological measurement*, 33(12), 2099.
11. Leuenberger, K., & Gassert, R. (2011, August). Low-power sensor module for long-term activity monitoring. In *2011 Annual International Conference of the IEEE Engineering in Medicine and Biology Society* (pp. 2237-2241). IEEE.
12. Brogioli, M., Popp, W. L., Schneider, S., Albisser, U., Brust, A. K., Frotzler, A., ... & Starkey, M. L. (2016). Multi-day recordings of wearable sensors are valid and sensitive measures of function and independence in human spinal cord injury. *Journal of Neurotrauma*.
13. Pierella, C., Abdollahi, F., Farshchiansadegh, A., Pedersen, J., Chen, D., Mussa-Ivaldi, F. A., & Casadio, M. (2014, August). Body machine interfaces for neuromotor rehabilitation: a case study. In *2014 36th Annual International Conference of the IEEE Engineering in Medicine and Biology Society* (pp. 397-401). IEEE.
14. Hooke, A. W., Morrow, M. M., An, K. N., & Kaufman, K. R. (2009). Capturing wheelchair propulsion kinematics using inertial sensors. In *33rd American Society of Biomechanics conference*.
15. Oliveira N., Blochlinger S., Ehrenberg N., Defosse T., Forrest G., Dyson-Hudson T., Barrance P. (2016). Synchronized wireless sensor system records differences in elbow flexion and pushrim force patterns during manual wheelchair propulsion in three different conditions. *RESNA conference, Arlington,VA*.

PS9.2: Common Sense about Usable, Accessible, and Inclusive Public Seating

Naomi J Petersen, EdD

Introduction

Although the Americans with Disabilities Act was passed a quarter century ago, inaccessibility remains common and often unacknowledged—even on university campuses that purport to have progressive ideals. In this article we examine the experience of wheelchair users and efforts to modify both architecture and curriculum to reduce barriers to their success, and place that into a framework of programmatic changes within institutions of higher education. Those barriers include the under addressed reality of social invisibility as well as a competitive academic culture, which confounds ideals of equitable access that legislation is designed to guarantee. Progress toward greater awareness and implementation is outlined according to pedagogical, political, and academic strategies observed at one mid-sized comprehensive university in a western American state, including the launch of a new Accessibility Studies Program intended to increase visibility and general knowledge of disability-related user experience.

Wheelchair Users

About a fifth of the population has some degree of disability that interferes with their functioning as independent adults. Of the many constraints interfering with typical independent living activities, the most conspicuous will be the physical incapacity that requires a wheelchair. Out of an estimated 4+ million people who identify as disabled, less than a fourth will be in wheelchairs, that is, using assistive technology for mobility. Thus about a million people, (5% of the population) are likely to require the architectural accommodations intended to guarantee access of a personalized wheeled vehicle. This narrow category of disability is nonetheless the hallmark of the Americans with Disabilities Act that prohibits discrimination against people with disabilities in employment, transportation, public accommodations, commercial facilities, telecommunications, and state and local government services.

As reported by the US Census, most people with disabilities do not complete higher education degrees nor find employment in white collar professions. It is thus of interest whether people with disabilities are attending the institution studied here. Central Washington University is a regional comprehensive university of 10,000 students. About 800 students are enrolled with Disability Services in order to receive some accommodations to help their academic success. Even accounting for a small percentage who will not identify as disabled, this is 10% of the total population. Given that easily half of all disabilities are associated with people over the age of 65, this would seem to be a representative proportion. These background statistics suggest that as many

as 40 students could be wheelchair users, and this prediction holds: ambulatory disabilities are identified by 20 students as their primary condition and by 19 as secondary. Specific mobility accommodations are requested by only 16 students. Therefore, on this large campus, relatively few students are conspicuously in need of wheelchair access. Their very invisibility tacitly perpetuates the systemic distortion of attitudes that wound dignity and are the focus of many reform efforts.

Progress towards Accessibility, Engagement, and Inclusion

Bolt (2015) warned that policies designed to protect people with disabilities from exclusion and discrimination will be ineffective unless social attitudes about disabilities change. To that end, DePoy and Gilson (2014) examined design and branding as powerful influences on perceptions and identities, including those related to disability. They go so far as to argue disability is a “designed and branded phenomenon” and that policies, services, structures, and products perpetuate the phenomenon unless directly challenged to redesign embodiment issues. These are politically charged critiques that advance efforts that Shapiro (1994) described as a civil rights movement “to be accepted on equal, independent terms without being patronized, segregated or victimized.” Thus there is a range of action inherent to the attitudes and a frustratingly persistent disconnect between progressive rhetoric and practical implementation. There has been a rhetorical shift in the symbols used to identify “ADA-compliant” or universally accessible paths and facilities. All show a stylized profile of a person in a wheelchair, changing from a literally headless body to gradually more dynamic, but still faceless and gender-neutral, occupants. In all cases of special need, etiquette now requires “people-first” language that focuses on the user’s experience rather than the condition affecting the experience.

Such progressive depictions of wheelchair use may be inspirational, but also a problematic development that romanticizes triumph over adversity instead of acknowledging wheelchair use as part of a public context that should be designed for universal accessibility.
Faculty Awareness and Implementation

As reported by the CWU Disability Services team, faculty are typically oblivious to the students’ user experience unless notified that a student with a disability is enrolled in their courses and is therefore eligible for accommodation. If brought to their attention, most faculty are happy to oblige if the demand for their energy and attention is not too distracting, but this requires an assertive (and diplomatic) advocacy typically provided by the students themselves or the Disability Services with which the student is registered.

Compared to disabilities of perception, e.g. sight and hearing impairment, or cognition or emotion, e.g. autism or dyslexia, physical disability requiring mobility assistance is less perplexing for faculty. The capacity to receive and express information is unimpaired, and the requirements necessary for thought and emotional processing are no different from the ‘typical’ student. However, there are some elements of user experience that merit specific attention.

Faculty do not have control over pathways or even the furnishings of a classroom, but they do have some influence over classroom configuration. There must be at least one designated space labeled as disability compliant. This is typically situated close to the door, out of a reasonable concern for the convenience of maneuvering a wheeled vehicle through the classroom. However, it means that the individual in a wheelchair will almost always be in the far right or left side, near the door. This violates the principle of dispersion and is also pedagogically suspect for instructors tend to favor one side over the other, and the use of screens for PowerPoint presentations mean that anchoring a person to a peripheral location that distorts the view of the presentation. Thus, the pathway to other locations in the room should be without obstruction.

The Academic Tradition of Exclusivity

This all begs the question of how the faculty are aware of a) the need to consider these students' experiences as well as b) the alternatives available for inclusion when c) exclusivity continues to be regarded with favor as a badge of quality. Some schools take pride in their low acceptance rate of applicants; some professors see student failure as a badge of their own academic rigor. This is not limited to research universities, but appears in regional comprehensives and liberal arts colleges as well. A tradition of competition is at odds with a more progressive ideology of equalizing the opportunities (Gardner, 1961).

Oslund (2015) examined the disparity between academic study of disability and the university services for all people—students, faculty, and staff—on campus with a longitudinal, qualitative study of how students with and without disabilities, instructors, staff members and administrators perceived the relative accessibility of teaching and learning on campus before, during, and after the implementation of accessibility legislation. The authors concluded that the legislation has had limited impact on the accessibility of teaching and learning. Such data is not collected routinely because in the US, monitoring is accomplished via compliance violation litigation rather than the monitoring of proactive efforts. Although compliance may be motivated as much by protecting institutional assets as protecting civil rights, the process of complying with the law results in a familiarity with the experiences that are intended to be modified.

ADA Requirements as a Tool for Enlightenment

The gradual implementation of standards for safety and access has raised awareness and increased participation of people who would otherwise be excluded and consequently less visible. This implementation is helped considerably by the comprehensive orientation to all environmental conditions affecting movement and user experience in typical scenarios of independent living found in the 2010 ADA guidelines. It is useful to consider the manner in which the regulations are organized, for they serve not only as a legal basis for advocates to demand reasonable accommodation, but also as a primer for the able-bodied to dissolve their ignorance of social invisibility. Their very specificity underscores the problem of "ableism", that is, assumptions that one's own capacities are commonly held.

ADA applies to fixed or built-in elements of buildings, structures, site improvements, and pedestrian routes or vehicular ways located on a site. Space needed for passage is also defined, as is practical usability of common accessories. These are framed in terms of their primary function, but some secondary functions may have the greater influence on the user experience of inclusion versus exclusion. Rather than confronting the attitudes directly, ADA 2010 patiently illuminate the actions interfering with full participation, often in the guise of a remedial physics lesson. Advisory language punctuates the entire document in an apparent effort to elevate it from sterile mechanics to a humane handbook. For instance, floor and ground surfaces are defined with the general criteria that they be stable, firm, and slip-resistant followed by impressively jargon-free definitions, explanations and guidelines.

The autonomy of the individual to traverse the path is key to a user experience that does not depend on asking for help. Dispersion is another criterion: Advisory 221.2.2 states "The requirement that wheelchair spaces be an 'integral part of the seating plan' means that wheelchair spaces must be placed within the footprint of the seating area. Wheelchair spaces cannot be segregated from seating areas. " Thus the regulations continuously underscore a social value of full integration, but this begs the question of who actually reads these regulations, who implements them, and who needs to be aware of their ramifications in our focus area: wheelchair users in classroom settings. The problem remains, however, that very few people actually read these guidelines.

An Academic Voice for Accessibility

There is, however, another means to bring these issues to light. By giving people with disabilities an academic voice, faculty will become more aware of and sensitive to their issues. To that end, it is worth calling attention to Central Washington University's new Accessibility Studies Program. The courses (e.g. Accessibility and User Experience; Universal Design; Assistive Technology: Tactile Graphics; Accessible Information Design) develop competencies for troubleshooting barriers. A recent survey of industries represented at a career fair confirmed that employers regard this as a valuable give the need for government vendors to provide an accessibility plan. Because the certificate and degree will be offered online, the program will be accessible for professional development.

If this is a harbinger of institutional evolution, then accessibility programs can provide a forum for raising issues of equity and implementation; participation in scholarly presentations from local to international scale provide an opportunity to highlight the challenges of implementing standards of universal design, e.g. a practical application of universal design and sensitivity to exclusion to all academic fields increases the general awareness of the pervasive attitudes and contextual influences on the lives, identities, and potential of this large population. Shifting away from prohibitions of discrimination towards proactive efforts at multi-faceted infrastructural inclusion based on a wider concept of accessibility, more programs such as this will likely be needed across the entire landscape of higher education, public policy and design.

References

1. ADA Standards for Accessible Design. (2010). Retrieved October 30, 2016, from https://www.ada.gov/2010ADASTandards_index.htm
2. Bolt, D., & Penketh, Claire. (2016). Disability, avoidance, and the academy : Challenging resistance (Routledge advances in disability studies). London ; New York: Routledge, Taylor & Francis Group.
3. DePoy, E., & Gilson, S. F. (2014). Branding and designing disability: reconceptualising disability studies. Abingdon, Oxon: Routledge.
4. Gardner, J. (1961). Excellence: Can we be equal and excellent too? NY: harper Colophon.
5. Oslund, C. (2015). Disability services and disability studies in higher education: History, contexts, and social impacts. Basingstoke, Hampshire: Palgrave Macmillan.
6. Shapiro, J. (1993). No pity: People with disabilities forging a new civil rights movement (1st ed.). New York: Times Books.

PS9.3: Wheelchair Rugby Project: Academic and Clinical Collaboration

Maria Eismann, BS, S/OT

Kevin Stahr, OTR/L, AT

Wendy Koesters, PT, ATP/SMS

Carmen P Digiovine, PhD, ATP/SMS, RET

Theresa F. Berner, MOT, OTR/L, ATP

High quality care is a priority for clinical practice reliant on the passion, clinical expertise, and experience of rehabilitation professionals in the healthcare field to improve the health and wellbeing of their clients. The introduction of evidence-based practice has provided a method for rehabilitation professionals to make informed decisions with the use of clinical and academic research as a guide. Simply defined, evidence-based practice integrates clinical expertise, client values, practice context, and research evidence to inform clinical decisions for effective health care (Sackett, 1996; Rappolt, 2003).

To expand the connection between clinical questions, research methods, and clinical decision making, recent health care research has emphasized the importance of integrating clinical practice and science-based research through the development and applicability of the role of the clinician scientist (Rosenblum, 2016). Clinician scientists complement research initiatives by (1) proposing clinically driven research questions, (2) collaborating with the research team, (3) collecting and analyzing data, and (4) serving as a qualified individual to implement new treatment approaches and ideas into clinical practice (Berner, 2016). This paper aims to provide an innovative and applicable example of the role of a clinical scientist in the context of a research project.

Building a Research Team and Initiation of a Clinical Question

This initiative was jump-started by the clinical curiosity and intrigue of two clinician scientists, one physical therapist and one occupational therapist, based on their experience working with adaptive sports and wheelchair rugby athletes. In collaboration with an occupational therapy graduate student and two research team advisors, a clinically driven investigation and literature review of shoulder pain overuse injuries in wheelchair rugby athletes was proposed and conducted. Initial findings sparked further intrigue and the steps to design and implement a research study were taken. By synergizing clinical, research, and academic perspectives, this collaborative effort allows current clinical practice to translate into evidence-based research through research design, data collection, analysis, presentation, and publication.

Background and Literature Review

Wheelchair rugby is a Paralympic team sport designed for individuals with disabilities, most commonly quadriplegia and other physical impairments. The sport originated in Canada under the initial name Murderball and is now an international sport with many active leagues in the United States (International Wheelchair Rugby Federation, 2012). Sport participation is known to have positive benefits for individuals, including the presence of a supportive, social network of teammates and coaches, and act as an outlet to work hard and build personal confidence (Machida, 2013). Wheelchair rugby is an active sport and requires physical engagement in preparation, practices, and games, as wheelchair rugby athletes train at an intensity associated with effective exercise and improved cardiorespiratory fitness (Barfield, 2010). An active lifestyle is also associated with improved wheelchair-specific fitness and is important to maintain active engagement in physical activities, such as wheelchair rugby (de Groot, 2015).

With active participation in wheelchair rugby, athletes are susceptible to injuries. Shoulder pain is a critical issue (Burnham, 1993; Curtis, 1999). Limitations in shoulder range of motion have been found to impact engagement in activities, and these limitations are associated with disability and perceived health (Ballinger, 2010; Erik Hoogland, 2015). While wheelchair sports may promote active use of the shoulder joint, overuse injuries are a concern (Fullerton, 2003; Cooper, 2014). There is no literature specifically examining shoulder pain and implemented therapeutic interventions for wheelchair rugby athletes, although evidence exists linking overuse injuries and declines in health (Cooper, 2014). Therefore, evidence supports further investigation and research regarding sports promotion, particularly wheelchair rugby, to address and prevent athlete overuse injuries.

Research Objectives

The research team conferred, discussed the supporting literature, and agreed to proceed with the research process. Three major project objectives were identified: (1) to collect information on wheelchair rugby athletes, including demographic information, disability classification, experience with wheelchair sports, technology use, and the environmental context; (2) to describe wheelchair rugby participation for wheelchair rugby athletes; and (3) to assess the prevalence, intensity, and specific category of shoulder pain in wheelchair rugby athletes. With technical expertise and input from the clinician scientists, the occupational therapy graduate student and lead research team advisors obtained official Institutional Review Board approval from The Ohio State University Office of Responsible Research Practices to conduct the following research endeavor.

Method

Study Design

The team initiated a prospective, longitudinal cohort study to collect data using applicable clinical measures and analyze results with relevant clinical implications. A convenience sample of 10 wheelchair rugby athletes from

a local wheelchair rugby team was recruited to participate. Both clinician scientists and the graduate student obtained informed consent from all participants prior to collecting data.

Data Collection and Analysis

Data collection focused on demographic information, disability classification, experience with wheelchair sports, and wheelchair rugby participation in the context of shoulder overuse injury and pain. The wheelchair rugby classification score was also recorded for each athlete, as it is an important distinction used in the game. All data were recorded via a verbal/written questionnaire completed by each participant. Descriptive statistics were used to summarize collected data.

Wheelchair Rugby Classification Score

In order to play, all wheelchair rugby athletes must transfer to specific wheelchairs designed for the sport and undergo a specific assessment to evaluate their ability to compete (Cooper, 2014). This classification process groups athletes into seven different classes based on their impairments and abilities which is designed to maximize an athlete's participation in wheelchair rugby by factoring in their level of physical impairment (International Wheelchair Rugby Federation, 2015; Tweedy, 2014). The classification system is used as a method to equalize athlete abilities between teams to ensure fair match-ups in competition.

Clinical Assessments

Two main clinical assessments with specific scoring guidelines were utilized to measure and assess functional ability and shoulder pain: (1) Wheelchair User's Shoulder Pain Index (WUSPI) and (2) Disability of the Arm, Shoulder, and Hand (DASH). These assessments are clinically relevant, evidence-based, and used readily in clinical practice.

Wheelchair User's Shoulder Pain Index (WUSPI)

The Wheelchair User's Shoulder Pain Index (WUSPI) is an evidence-based assessment used to measure and assess shoulder pain in individuals who use wheelchairs regarding basic and fundamental activities of daily living (Curtis, 1995). It includes sections for participant information, a brief medical history, and a 15-item index to rate shoulder pain interference in four main categories: transfers, wheelchair mobility, self-care, and general activities (work, school, and sleep). The WUSPI has established test-retest reliability, internal consistency, and concurrent validity (Curtis, 1995).

Disability of the Arm, Shoulder, and Hand (DASH)

The Disability of the Arm, Shoulder, and Hand (DASH) is a self-report questionnaire used to assess limitations specific to the upper extremity (Hudak, 1996). This 30-item assessment examines the level of difficulty associated with functional activities, pain, and includes work and sports/performing arts modules (Kennedy,

2011). The DASH has overall good reliability, validity, and an established minimal important clinical difference (MCID) (Angst, 2011; Franchignoni, 2014).

Results

Corresponding demographic information, wheelchair rugby classification score, DASH score, and WUSPI score for each participant are presented in Table 1. All participants were male with age range 25 to 44 years old and cervical spinal cord injuries. Wheelchair rugby classification scores ranged from 0.5 to 3.0, with data from one participant missing. The average overall DASH score was 32.10, average work DASH score was 13.54, and average sports DASH score was 25.62. Based on normative DASH data, six participants' overall scores, one participant's work scores, and four participants' sports scores fell outside one standard deviation from the mean (Hunsaker, 2002). The average WUSPI score for continuous scores was 22.6. Nine participants' WUSPI scores were greater than 1.0, which indicates self-report of shoulder pain, and four participants' WUSPI scores were greater than 20.0 (Brose, 2008).

Table 1

Characteristics of Wheelchair Rugby (WCR) Athletes

Participant	Demographics	WCR Classification Score	DASH Score	WUSPI Score
1	Male, 40 years old, C4-C6 incomplete spinal cord injury (SCI), 23 years playing wheelchair sports	1.5	39.65 Work: 0.0 Sports: 68.75	57.0
2	Male, 27 years old, C6-C7 incomplete SCI, 6 years playing wheelchair sports	2.0	30.0 Work: 0.0 Sports: 0.0	2.7
3	Male, 39 years old, C6 complete SCI, 22 years playing wheelchair sports	0.5	16.67 Work: 0.0 Sports: 0.0	12.8
4	Male, 25 years old, C7 incomplete SCI, 5 1/2 years playing wheelchair sports	2.5	32.5 Work: 0.0 Sports: 25.0	32.0*
5	Male, 44 years old, C6 incomplete SCI, 8 years playing wheelchair sports	2.0	37.93 Sports: 43.75	44.0*
6	Male, 29 years old, C7 complete SCI, 6 years playing wheelchair sports	2.5	20.83 Sports: 0.0	0.0
7	Male, 37 years old, C5-C6 incomplete SCI, 11 years playing wheelchair sports	0.5	23.33 Sports: 18.75	44.8
8	Male, 32 years old, C5-C6 incomplete SCI, 1 year playing wheelchair sports	**	57.55 Work: 18.75 Sports: 43.75	18.7
9	Male, 32 years old, C5 incomplete SCI, 4 years playing wheelchair sports	1.0	62.50 Work: 62.50 Sports: 56.25	6.0*
10	Male, 37 years old, C6-C7 incomplete SCI, 9 years playing wheelchair sports	3.0	0.0 Sports: 0.0	1.5*

*WUSPI scores calculated on interval scale 1-10, compared to other WUSPI scores calculated on continuous scale 0-10

** Missing data point

Discussion

This is the first research study designed to examine shoulder pain specifically among wheelchair rugby athletes and, as these data serve as preliminary research findings for the larger study, the presented demographic and disability information provides an initial snapshot of the wheelchair rugby team and individual athlete. Focusing on athletes and their engagement in sports, these data may be valuable to a variety of sports and rehabilitation professionals since evidence supports active participation in sports, physical exercise, and recreational activities contribute positively to both quality of life and self-esteem (Laferrier, 2015). Listed participant characteristics allow both rehabilitation professionals and researchers to draw comparisons between their target population and the information collected from the study sample to inform both clinical and academic pursuits.

Both the WUSPI and DASH scores support the presence of shoulder pain among wheelchair rugby athletes, as shoulder pain was self-reported and categorized outside normative data by at least six of ten participants on the DASH and nine of ten participants on the WUSPI (Brose, 2008; Hunsaker, 2002). As both of these clinical assessments are designed to detect the functional impact of shoulder pain, this is important knowledge for rehabilitation professionals when designing and targeting specific intervention strategies (Cratsenberg, 2015; Mulroy, 2015). Future data collection time points will allow for DASH and WUSPI minimally important clinical difference (MCID) calculations to provide further insight into the initial clinically driven mission to investigate this phenomenon.

Study Limitations

As this study is a prospective cohort study, limitations include a small, convenient sample size, selection bias, risk for loss to follow-up (attrition), self-reported data, and potential confounding variables, as this study did not involve randomization. One data point was missing due to an incomplete response on the written questionnaire. Study participants are not representative of the entire population of wheelchair rugby athletes, but data does provide useful information to investigate the presented research aims.

Future Directions and Implications for Clinical Practice

Ongoing clinical and research work will continue from all team members to further investigate this clinical issue as it is expected that shoulder pain prevalence and intensity will increase with time. Data will continue to be collected from wheelchair rugby athletes with the ultimate goal to develop and design interventions including, but not limited to, therapeutic interventions, stretching routines, strengthening exercises, and guidelines for shoulder pain management. By integrating a health and wellness approach to shoulder overuse injuries in the context of adaptive sports, wheelchair rugby athletes are allowed more time in the game and engaged in the sport they enjoy.

Connection to the Clinician Scientist

The presented data, discussion, and clinical implications are made possible by the collaboration of the research team where each member is able to further develop their skills as a clinician scientist. The knowledge base provided by the graduate occupational therapy student and research advisor to operationalize the research methodology partnered with the clinical expertise of the clinicians allowed for a well-rounded, standardized research project relevant to real-time clinical practice. Not only was the project able to generate numerical data for research, but it also provided participants with applicable clinical assessment results revealing problem areas pertinent to an important and valued pastime, wheelchair rugby. The most beneficial aspect of this research endeavor was arguably the ability to disseminate these research findings to a widespread audience in a timely manner, as the initial project proposal, IRB approval, and data collection were completed within six months.

Conclusion

With an ever changing clinical atmosphere and the push for evidence-based practice, the role of the clinician scientist plays an important part in the future of health care. This research project stems from the success of effective communication, teamwork, and respect for professional experience as the clinician scientist emerges as a unique collaborator. Integrating both research and clinical knowledge, findings have both rigor and value important to both target audiences, ultimately fostering the common effort to focus on health and wellness for all clients.

References

1. Angst, F., Schwyzer, H., Aeschlimann, A., Simmen, B.R., & Goldhahn, J. (2011). Measures of adult shoulder function: Disabilities of the Arm, Shoulder, and Hand Questionnaire (DASH) and its short version (QuickDASH), Shoulder Pain and Disability Index (SPADI), American Shoulder and Elbow Surgeons (ASES) Society standardized shoulder assessment form, Constant (Murley) Score (CS), Simple Shoulder Test (SST), Oxford Shoulder Score (OSS), Shoulder Disability Questionnaire (SDQ), and Western Ontario Shoulder Instability Index (WOSI). *Arthritis Care and Research*, 63 (S11). doi:10.1002/acr.20630.
2. Ballinger, D.A., Rintala, D.H., & Hart, K.A. (2000). The relation of shoulder pain and range-of-motion problems to functional limitations, disability, and perceived health of men with spinal cord injury: a multifaceted longitudinal study. *Achieves Physical Medicine Rehabilitation*, 81, 1575-1581. doi:10.1053/apmr.2000.18216.
3. Barfield, J.P., Malone, L.A., Arbo, C., & Jung, A.P. (2010). Exercise intensity during wheelchair rugby training. *Journal of Sports Science*, 28 (4), 389-398. doi:10.1080/02640410903508839.
4. Berner TF, Sawatzky B, DiGiovine CP, Roesler T. (2016) The Clinician Scientist in the Seating and Mobility Clinic: A foundation for Education, Research, and Clinical Practice. *International Seating Symposium*, Vancouver, BC, Canada. 1-4

5. Brose, S. W., Boninger, M. L., Fullerton, B., McCann, T., Collinger, J. L., Impink, B. G., & Dyson-Hudson, T. A. (2008). Shoulder ultrasound abnormalities, physical examination findings, and pain in manual wheelchair users with spinal cord injury. *Archives of physical medicine and rehabilitation*, 89(11), 2086-2093. doi:10.1016/j.apmr.2008.05.015.
6. Burnham, R., May, L., Nelson, E., Steadward, R., & Reid, D. (1993). Shoulder pain in wheelchair rugby athletes. *The American Journal of Sports Medicine*, 21 (2), 238-242.
7. Cooper, R. A., & De Luigi, A. J. (2014). Adaptive Sports Technology and Biomechanics: Wheelchairs. *PM&R*, 6(8), S31-S39. doi:10.1016/j.pmrj.2014.05.020.
8. Cratsenberg, K., Deitrick, C., Harrington, T., Kopecky, N., Matthews, B., Ott, L. & Coeytaux, R. (2015). Effectiveness of exercise program for management of shoulder pain in manual wheelchair users with spinal cord injury. *Journal Neurological Physical Therapy*, 39, 1-7. doi: 10.1097/npt.000000000000103.
9. Curtis, K.A., Roach, K.E., Applegate, E.B., Amar, T., Benbow, C.S., Genecco, T.D., & Gualano, J. (1995). Development of the wheelchair user's shoulder pain index (WUSPI). *Paraplegia*, 33 (5), 290-293. doi: 10.1038/sc.1995.65.
10. Curtis, K.A., Roach, K.E., Applegate, E.B., Amar, T., Benbow, C.S., Genecco, T.D., & Gualano, J. (1999). Reliability and validity of the wheelchair user's shoulder pain index (WUSPI). *Paraplegia*, 33 (10), 595-601.
11. DeGroot, S., van der Scheer, J., Bakkum, A., Adriaansen, J., Smit, C., Dijkstra, C., Post, M., & van der Woude, L. (2015). Wheelchair-specific fitness of persons with long-term spinal cord injury: cross-sectional study on effects of time since injury and physical activity level. *Disability Rehabilitation*. doi:10.3109/09638288.2015.1076072.
12. Eriks-Hoogland, I.E., de Groot, S., Snoek, G. Stucki, G., Post, M.W.M., & van der Woude, L.H.V. (2015). Association between shoulder problems in persons with spinal cord injury at discharge from inpatient rehabilitation with activities and participation at 5 years later. *Archives of Physical Medicine and Rehabilitation*. doi: 10.1016/j.apmr.2015.08.432.
13. Frachignoni, F., Vercelli, S., Giordano, A., Sartorio, F., Bravini, E., & Ferriero, G. (2014). Minimal Clinically Important Difference of the Disabilities of the Arm, Shoulder and Hand Outcome Measure (DASH) and Its Shortened Version (QuickDASH). *Journal Orthopedic Sports Physical Therapy*, 44 (1), 30-39.
14. Fullerton, H.D., Borckardt, J.J., & Alfano, A.P. (2003). Shoulder pain: a comparison of wheelchair athletes and nonathletic wheelchair users. *Medicine and Science in Sports and Exercise*, 35 (12), 1958-1961. doi: 10.2519/jospt.2014.4893.
15. Hudak, P.L., Amadio, P.C., & Bombardier, C. (1996). Development of an upper extremity outcome measure: the DASH (disabilities of the arm, shoulder, and hand). *American Journal of Industrial Medicine*, 29 (6), 602-608. doi: 10.1002/(sici)1097-0274(199606)29:6<602::aid-ajim4>3.0.co;2-l.
16. Hunsaker, F. G., Cioffi, D. A., Amadio, P. C., Wright, J. G., & Caughlin, B. (2002). The American academy of orthopaedic surgeons outcomes instruments. *J Bone Joint Surg Am*, 84(2), 208-215.
17. International Wheelchair Rugby Federation (2015). IWRP Classification Manual 3rd edition. Retrieved from www.iwrf.com.
18. Kennedy, C.A., Beaton, D.E., Solway, S., McConnell, S., & Bombardier, C. (2011). The DASH outcome measure user's manual 3rd edition. Toronto: Institute for Work and Health.
19. Machida, M., Irwin, B., & Feltz, D. (2013). Resilience in competitive athletes with spinal cord injury; the role of sports participation. *Qualitative Health Research*, 23 (8), 1054-1065. doi:10.1177/1049732313493673.
20. Mulroy, S.J., Hatchett, P., Eberly, V.J., Lighthall Haubert, L., Conners, S., & Requejo, P.S. (2015). Shoulder strength and physical activity predictors of shoulder pain in people with paraplegia from spinal cord: prospective cohort study. *Physical Therapy*. 95(7) 1027-1038. doi: 10.2522/ptj.20130606.
21. Rappolt, S. (2003). The role of professional expertise in evidence-based occupational therapy. *The American Journal of Occupational Therapy: Official Publication of the American Occupational Therapy Association*, 57(5), 589-593. doi: 10.5014/ajot.57.5.589.
22. Rosenblum, N. D., Kluitmans, M., & Cate, O.T. (2016). Professional Identity Formation and the Clinician-Scientist: A Paradigm for a Clinical Career Combining Two Distinct Disciplines. *Academic Medicine: Journal of the Association of American Medical Colleges*, 1. doi: 10.1097/acm.000000000000125.
23. Sackett, D. L., Rosenberg, W. M., Gray, J. A., Haynes, R. B., & Richardson, W. S. (1996). Evidence based medicine: what it is and what it isn't. *BMJ (Clinical Research Ed.)*, 312(7023), 71-72.
24. Tweedy, S.M., Beckman, E.M., & Connick, M.J. (2014). Paralympic classification: conceptual basis, current methods, and research update. *Paralympic Sports Medicine and Science*, 6 (8), S11-S17. doi: 10.1016/j.pmrj.2014.04.013.

PS9.4: Self-care Mobile Health Platform for Individuals with Spinal Cord Injury

Andi Saptono, Ph.D.
Agus Setiawan

Background

Secondary health conditions (SHCs) in the Spinal Cord Injury (SCI) population, such as urinary tract infection, pressure ulcers, and depression, have been identified as significant factors that contribute to increased emergency department visits and hospitalizations (Guilcher, 2013). Over time, these visits and hospitalizations may lead to reduced participation in community, lower quality of life, and lower life expectancy (Krause, 2004). Studies have shown that these situations can be prevented through adherence to self-care/self-management routines. With proper self-care routines, individuals with SCI's health outcomes may be improved. They can also be empowered to become more independent in their self-care activities (Kinsman, 1996; Lorig, 2003). Self-care activities, such as self-catheterization, managing wounds and skin issues, and checking mood, can feasibly be facilitated by mobile health platform (mHealth) because of its 'always close, always present' nature (Parmanto, 2013). Through providing cues for self-care routines from a close vicinity at the appropriate time, previous study in mHealth for individuals with Spina Bifida indicates significant reduction in hospitalizations and emergency room visits (Dicianno, 2016). However, the study also found challenges in sustaining the engagement of individuals as well as motivating these individuals to actively utilize the mHealth platform.

Three methods were investigated to sustain the engagement of individuals in mHealth: gamification, social support, and personalized education. Gamification, the inclusion of elements of game playing into other areas of activity, has been considered as a potential method to encourage and sustain engagement with a product or service. Implementing this method in mHealth has the potential to help sustain the engagement of individual with SCI toward mHealth. To explore the feasibility of sustaining engagement through gamification in mHealth, a pilot study added gaming elements into activities related to self-care on the interactive Mobile Health and Rehabilitation (iMHere) system. For example, adherence to medication schedule will produce points that can be accumulated and reimbursed at a later time for either a virtual or a real-world reward. Also, as part of the gamification, individuals can set their own expectations and goals in self-care tasks. Individuals can rate their own performance when a goal is achieved and compare it with their original expectations. Based on the result, they can then either refine their previous goal's expectations or create new goals with greater expectations. These achievements can be shared with their clinicians, wellness coordinator, and/or caregivers, which can then be responded by positive feedback, encouragement, or reward points.

The second method investigated in the pilot study was to provide a social support through iMHere. Studies have reported that satisfying social support for individuals with SCI improve life satisfaction as well as reduce depressive symptomatology (Rintala, 1992). In iMHere, a method of social support was implemented in the form of a caregiver app. This app is distributed to caregivers for individuals with SCI and 'pairs' with a client app given to their cared ones. The caregiver app functions as a platform to assist caregivers in observing their cared ones' adherence to self-care tasks. In addition, the app also contains gamification features that allows caregiver to encourage their cared ones to achieve their goals. For example, caregivers can set up real-world reward as a bonus for achieving certain self-care goal. Caregivers can also use the app to communicate securely with clinicians and wellness coordinator. All of these functions are designed to be 'light', providing sufficient information for supporting individuals with SCI without burdening caregivers.

Personalized education was the third method investigated in the pilot study. An interactive educational module was developed within iMHere to provide information surrounding the condition of an individual with SCI. This information can be presented in the form of textual information, video, or audio recording. The educational module's content is presented in sections and can be accessed through the client app. By activating or deactivating the sections, the wellness coordinator can control the availability of the content within the educational module. This capability allows wellness coordinator to tailor the education process by presenting relevant educational materials at the appropriate time.

Methods

The study utilizes several round of focus groups to investigate the implementation of the engagement methods in iMHere. The goals of the study were: (1) to identify potential weakness of the implementation; (2) to identify potential refinement for the implementation; and (3) to search for any new method of engagement beyond the ones already implemented in iMHere. The study conveniently invited both individuals with SCI and their parents/caregivers to participate in the focus group during a youth weekend camp. The result reported in this article originated from the first focus group round. Participants were divided into two groups based on their roles: the client group which hosts potential primary users of iMHere (teens and young adults with SCI) and the caregiver group which hosts the potential users of caregiver app.

Findings

A quick survey conducted prior to the focus group session revealed that smartphone usage was common within both groups. Based on the participants' response, the smartphone was mostly used for communication, gaming, and social media interaction. However, only a limited number of participants were actively using the smartphone as an mHealth tool. Although the focus group participants have limited knowledge in mHealth, their experience in the usage of smartphone still allowed them to assess the implementation of the method to sustain engagement with iMHere.

The introduction of gamification in iMHere was received positively by the participants. Participants in the client group mentioned that the gamification features provided by iMHere were attractive and could potentially motivate them to perform their self-care activities as long as the rewards are relevant to their interest. For example, participants mentioned that the real-world rewards should be relevant with their hobbies, such as purchasing music, watching movies, or camping. These participants were also interested to share their achievements and information about their rewards with their friends through social media. Participants in the caregiver group agreed with the feedback provided by their cared ones, however they would need assurance that their cared ones truly adhere to the self-care activities scheduled within the app before giving out the reward.

The caregiver app was also received positively by the caregiver group. In addition to passive observance to their cared ones' self-care activities, participants in the caregiver group also mentioned some potential active involvements that can be built into the caregiver app, such as the ability to remind their cared ones on their missed schedules, the ability to send a 'thumbs-up' message when their cared ones completed all schedules in a certain period of time, or the ability to assist the creation of a new schedule remotely. Participants in the client group mentioned that they would like the ability to control the information being displayed in the caregiver app. They also agreed that some active involvements from their caregivers could be beneficial, for example the caregiver app can remind their caregivers to assist in reordering medications.

Both client and caregiver group received the personalized education positively. The participants in the client group mentioned that they are delighted to be able to understand more of their condition by accessing the information in the educational module. They also mentioned that by using these information, they could potentially be able to explain their condition better to their friends, teacher, or anyone else that inquired about their condition. However, they also suggested that the information should be summarized, coupled with the ability to dig deeper into topics that interest them whenever they want, instead of placing all information in a text-book format. They also mentioned that video-graphic presentation would be more pleasant to view rather than textual presentation. Participants in the caregiver group added a suggestion to allow caregivers to expand the educational module themselves. They would like to enrich the educational module with other potentially interesting topics for their cared ones, such as information surrounding their cared ones hobbies.

Discussion

The feedbacks received during the first round of focus group were compiled and listed as potential refinement ideas to further develop iMHere. New ideas, such as the ability to expand educational module and the ability to share achieved goals through social media are currently being assessed. Overall, the positive receptions from the focus group seemed to indicate that these methods are feasible and could potentially keep individuals with SCI and their caregivers engaged with mHealth.

References

1. Guilcher, S. J., Craven, B. C., Lemieux-Charles, L., Casciaro, T., McColl, M. A., & Jaglal, S. B. (2013). Secondary health conditions and spinal cord injury: an uphill battle in the journey of care. *Disabil Rehabil*, 35(11), 894-906.
2. Krause, J. S., DeVivo, M. J., & Jackson, A. B. (2004). Health status, community integration, and economic risk factors for mortality after spinal cord injury. *Arch Phys Med Rehabil*, 85 (11), 1764-1773.
3. Kinsman SL, Doehring MC: The cost of preventable conditions in adults with spina bifida. *Eur J Pediatr Surg* 1996;6(suppl):17-20
4. Lorig KR, Holman HR: Self-management education: history, definition, outcomes, and mechanisms. *Ann Behav Med* 2003;26:1-7
5. Parmanto, B., Pramana, G., Yu, D. X., Fairman, A. D., Dicianno, B. E., & Mccue, M. P. (2013). IMHere: A Novel mHealth System for Supporting Self-Care in Management of Complex and Chronic Conditions. *JMIR Mhealth and Uhealth*, 1(2)
6. Dicianno, B. E., Fairman, A. D., Mccue, M., Parmanto, B., Yih, E., Mccoy, A., Brienza, D. M. (2016). Feasibility of Using Mobile Health to Promote Self-Management in Spina Bifida. *American Journal of Physical Medicine & Rehabilitation*, 95(6), 425-437.
7. Rintala, D. H., Young, M. E., Hart, K. A., Clearman, R. R., & Al, E. (1992). Social support and the well-being of persons with spinal cord injury living in the community. *Rehabilitation Psychology*, 37(3), 155-163.

IC73: Custom Molding; Who, Why and How Tips from the Collaborative Team

Lindsey Veety, PT, DPT, ATP

Barbara Sipper, PTA

Marc Rosen, ATP

Learning Objectives:

- Describe 3 benefits of a thorough clinical evaluation on the custom molding process
- Discuss 3 steps for properly preparing the environment for an optimal custom seat mold
- List 3 techniques to use during the molding/fitting process to optimize outcomes
- List 2 outcomes used to evaluate a client to determine a successful custom molded seat
- List 2 benefits that proper custom molded seating will have on function for a client

Nothing is more frustrating than looking at a client and their seating system and seeing that it does not match their needs. Not having a good match can lead to an increased risk of skin breakdown (1,2) or a decrease in functional ability due to the lack of postural support (3). To achieve optimal results when a complex patient enters a seating clinic, it requires a team of professionals. This team includes a therapist who has a background in complex mobility, an assistive technology supplier, the individual, their family and any other caregivers and support staff who interact with the individual on a daily basis. This session will focus on the process our team takes to achieve optimal results when a complex patient enters the clinic and is determined they require custom molded seating. The presenters will take the participants from start to finish when a client enters the seating clinic including vital tips to improve how the custom molding process is done, using examples, pictures and case studies to illustrate.

When an individual enters the clinic, a thorough clinical evaluation is a necessity. A comprehensive history is paired with a complete clinical evaluation. The clinical evaluation looks at how the musculoskeletal, neuromotor, respiratory and sensory systems function together in different planes and during a combined seated and supine evaluation. It looks at the spine, pelvis and extremities and their relation to each other and how this is changed with the addition of gravity (4,5). Flexibility and the ability to correct vs. the need to support are also important decisions which are often determined during the initial evaluation, and how these play a critical role in custom molded seating. Establishment and prioritizing of team goals is also a critical component of an evaluation for optimizing outcomes. Some examples of client goals may include the need to be upright for managing secretions or improving respiration by altering support or making the chair the appropriate size so it can be used in all locations by the user.

Once the evaluation has been completed goals are set by the team. The custom molded chair can be selected and submitted for funding approval and the custom molding process begins. Tips and techniques to optimize the final seating outcome that our team uses will be shared. These will include optimizing seat to back angle to compliment the findings from the initial therapy evaluation, and using tilt functions on the molding simulator to your advantage during the molding process to obtain optimal positioning for the duration of the molding time. The use of visual observation, tactile representation vs. pressure mapping during molding, and then manipulating the shape of the molding bags after the client is out of the bag for an improved outcome are all methods of determining whether you have captured the shape of the client, as well as where the client is weight bearing. Loading surfaces appropriately is critical, not only for comfort, but also to reduce the risk of breakdown in the future. Discussion will include tips for digitizing vs. scanning after the mold is completed and the advantages of each. Selecting foam and alternate material types, as well as cut outs, or inserts, and the benefits of mid-fittings prior to delivery when appropriate will be discussed (6,7). Different types of molding manufacturers and systems will also be covered.

Finally, determining a successful outcome and the need for follow-up and/or re-evaluation is essential. Items such as a decrease in pressure sores/wounds, improvement in functional skills, respiratory functional measures, changes in activities such as breathing, eating or vocalizing can all be used as measures of success within the seating clinic setting. Training the family and caregiver team at delivery on what to look for and when to return to clinic regarding proper fit in a chair is key to a successful long term outcome. Follow-up can occur in the form of a phone call or a follow-up visit, but is critical.

This session is being presented by a combined clinical and vendor team, to show that when the team collaborates and thinks outside the box, the client will achieve the optimal outcome.

References:

1. Brienza, D, Kelsey, S, Karg, P, Allegretti, A, Olson, M, Schmeler, M, Zanca J, Geyer MJ, Kusturiss, M, Holm, M. A randomized clinical Trial on Preventing Pressure Ulcers with Wheelchair Cushions. *Journal of the American Geriatrics Society*, 58: 2308-2314, 2010.
2. Tasker LH1, Shapcott NG, Watkins AJ, Holland PM. The effect of seat shape on the risk of pressure ulcers using discomfort and interface pressure measurements. *Prosthet Orthot Int.* 2014; 38(1): 46-53. doi: 10.1177/0309364613486918. Epub 2013 May 17.
3. Costigan, F. A., & Light, J.. Functional Seating for School-Age Children With Cerebral Palsy: An Evidence-Based Tutorial. *Language, Speech, and Hearing Services in Schools* , 223-236, 2011.
4. Cook, A. & Polgar J. (2008) *Assistive Technologies-Principle and Practice*. 3rd edition. Mosby Elsevier.

-
5. Waugh, K., & Crane, B (2013). A clinical application guide to standardized wheelchair seating measures of the body and seating support surfaces. Denver, Colorado, University of Colorado Denver (363 pgs), Funded by the Paralyzed Veterans of America Education Foundation Grant # 668. Retrieved from: <http://www.ucdenver.edu/academics/colleges/medicalschoo/programs/atp/Resources/>
 6. Custom Molded Seating: Choosing the right system for your client. Petito, Cindi; Young, Mary Hitt; Rehab Management: The Interdisciplinary Journal of Rehabilitation, Mar2011; 24(2): 22-24. 3p. (Journal Article - pictorial) ISSN: 0899-6237 PMID: 21428271
 7. Cindi Petito, Mary Hitt Young, Custom Molded Seating. Rehab Mgmt. 2011; Mar 4 <http://www.rehabpub.com/2011/03/custom-molded-seating/>

IC74: Providing Assistive Technology for the MS Client

Carina M Siracusa, PT

Lauren Esposito, PT, DPT

Andrea Stump, PT, DPT, NCS

Background

Patients diagnosed with multiple sclerosis have a variety of ever changing mobility needs. Whether they are seen at a multi disciplinary clinic for their MS or at one neurologists, it can be difficult to prescribe mobility for these patients due to the complexity of progression and symptoms of the disease. At OhioHealth, patients diagnosed with multiple sclerosis are seen at a multidisciplinary clinic where they see multiple providers in one visit. These are mostly screening visits and then patients are given instructions to follow up with individual providers based on their needs. The patient is generally seen by a neurologist, a nurse practitioner, a social worker, physical, occupational and speech therapists and supportive care. The physical therapists specifically are assessing mobility at these visits and making recommendations about assistive devices. They take into account the patient's current mobility, but also look at the physician prognosis and most recent scans. They then refer patients to the seating and mobility clinic if appropriate.

During mobility clinic it can be very difficult to assess for the proper form of mobility for these patients. If they have relapsing-remitting multiple sclerosis they might happen to be seen in clinic on a "good" day. This can make it difficult to truly assess what their mobility needs are, as well as to paint an adequate picture for funding purposes. The mobility therapists has to have an extensive knowledge of the types of MS as well as regular disease progression. At OhioHealth, the mobility therapists rely heavily on the clinic therapists because they have seen the patients over a longer period of time. Together they can paint a true clinic picture for funding in order to make sure that these patients have a usable and functional mobility device.

Discussion

There will be two parts to this presentation. A therapist that is part of the MS Clinic team will discuss the types of MS as well as the traditional disease progression. She will discuss functional outcome measures that are validated in the MS population, as well as typical mobility and physical therapy concerns with this extremely complicated patient population.

During the second half of the presentation, the mobility and seating clinic specialist will discuss the mobility evaluation for a patient with multiple sclerosis including typical functional outcome measures and MRADL considerations. The therapist will also discuss funding considerations and how to paint an accurate clinical picture of the patient while still attempting to get an appropriate assistive device funded.

The therapists will discuss several case studies of MS Clinic patients and their journey to receive an assistive device.

Conclusion

In order to properly prescribe an assistive device for a patient with MS with a constantly changing clinical picture, it is important to involve an interdisciplinary team in order to ensure that a proper mobility device is dispensed and funded accordingly.

References:

1. Rice IM, Rice LA, Motl RW. Promoting Physical Activity Through a Manual Wheelchair Propulsion Intervention in Persons With Multiple Sclerosis. *Arch Phys Med Rehabil.* 2015 Oct;96(10):1850-8.
2. De Souza LH, Frank AO. Problematic clinical features of powered wheelchair users with severely disabling multiple sclerosis. *Disabil Rehabil.* 2015;37(11):990-6
3. Stevens V, Goodman K, Rough K, Kraft GH. Gait impairment and optimizing mobility in multiple sclerosis. *Phys Med Rehabil Clin N Am.* 2013 Nov;24(4):573-92
4. Iezzoni LI, Rao SR, Kinkel RP. Experiences acquiring and using mobility aids among working-age persons with multiple sclerosis living in communities in the United States. *Am J Phys Med Rehabil.* 2010 Dec;89(12):1010-23.
5. Souza A, Kelleher A, Cooper R, Cooper RA, Iezzoni LI, Collins DM. Multiple sclerosis and mobility-related assistive technology: systematic review of literature. *J Rehabil Res Dev.* 2010;47(3):213-23.

IC75: The Clinician Scientist: A Foundation for Leadership

Carmen P Digiovine, PhD, ATP/SMS,
RET

Theresa F. Berner, MOT, OTR/L, ATP

Tina L Roesler, PT, MS, ABDA

Clinician (e.g. occupational therapists, physical therapists and rehabilitation engineers) are better trained to evaluate and apply innovative research, technologies and program models into clinical practice as a result of clinical doctorate programs, residency programs, engineering internships, and formal mentorship programs. The clinician scientist represents the application of education (professional development, precepting, internships), research and development (collaboration with researchers and industry partners), and clinical practice (evidence based practice and program development).

Learning Objectives:

Upon completion of this session, attendees will be able to;

- List the four core components of the clinician scientist.
- Describe examples of the clinician scientist role in a seating and mobility clinic.
- Identify one way you can advance your skills as a clinician scientist.

References:

1. Rosenblum, N. D., Kluijtmans, M., & Ten Cate, O. (2016). Professional Identity Formation and the Clinician-Scientist: A Paradigm for a Clinical Career Combining Two Distinct Disciplines. *Academic Medicine: Journal of the Association of American Medical Colleges*.
2. Roberts, S. F., Fischhoff, M. A., Sakowski, S. A., & Feldman, E. L. (2012). Perspective: Transforming science into medicine: how clinician-scientists can build bridges across research's "valley of death." *Academic Medicine: Journal of the Association of American Medical Colleges*, 87(3), 266–270.
3. Dyer, J. H., Gregersen, H. B., & Christensen, C. M. (2009). The Innovator's DNA. *Harvard Business Review*, 87(12), 60–67.

IC76: Training and Education for Novice Wheelchair Users

Hsin-Yi Liu, PhD, PT

Theresa Marie Crytzer, DPT, ATP

Alexandra Bennewith, MPA

Jennifer Wolff, OT

Background

Wheelchair seating professionals, including physical and occupational therapists, physiatrists, and assistive technology providers, play an important role in the evaluation and provision of wheelchairs and wheelchair skills training for consumers with disabilities. After receiving a wheelchair, the day-to-day management of health and function rests in the consumers' hands. However, potential and novice wheelchair users often lack access and/or knowledge of resources, rendering the process of obtaining, using and maintaining a new wheelchair overwhelming and stressful (Krantz, Edberg, Persson, & Reg, 2011).

Studies have suggested that providing materials and tools for patient education and self-management would improve people's attitudes and behaviors to comply with recommendations for health, quality of life, clinical symptoms, and use of health resources (Lorig & Holman, 2003; Warsi, Wang, LaValley, Avorn, & Solomon, 2004). Thus, improving consumer access and knowledge about the wheelchair service delivery process and wheelchair use is essential to empowering novice wheelchair users to self-advocate for their needs, facilitate independent living, and prevent secondary health conditions, (e.g. repetitive strain injuries).

Several credible clinical and educational facilities and advocacy associations have developed and published online educational materials for consumers regarding wheelchair selection and usage. United Spinal Association (<http://www.unitedspinal.org/>) and the Model Systems Knowledge Translation Center (<http://www.msktc.org/>) are examples of organizations dedicated to providing the latest evidence-based information on wheelchair selection, provision and use to aid wheelchair users in the decision-making process. The Rehabilitation Engineering & Assistive Technology Society of North America (RESNA) also published a wheelchair service provision guide for professionals that recommends the essential steps in the wheelchair service delivery process, and position papers describing the evidence supporting appropriate wheelchair selection for end users (Arledge et al., 2011; Arva, Schmeler, Lange, Lipka, & Rosen, 2009; Dicianno et al., 2009; DiGiovine, Berner, Betz, Roesler, & Schmeler, 2012). Evidence based educational materials such as these are accessible online, but consumers will need to dig through many websites and webpages to find them. A platform to present key information and provide interactive guide at consumers' fingertips will help consumers to obtain essential knowledge timely and efficiently.

Smartphones have become an essential tool for delivering educational materials to a wide audience because of their portability and capacity to present multi-media materials (Free et al., 2013). Smartphones can also provide reminders and tracking tools for consumers to manage their health. Sixty-two percent of the United States population own smartphones, and 58% of smartphone users downloaded at least one health related application (Krebs & Duncan, 2015). Our research team collaborated with United Spinal Association to develop a smartphone app to guide consumers through the wheelchair service delivery process, and provide essential materials about safe and effective wheelchair use for potential and novice wheelchair users. Our aim was to equip consumers with knowledge and motivation to negotiate the wheelchair service delivery process, improve self-advocacy, make the best use of their new wheelchairs, maintain their wheelchairs in the best condition, and manage their health and safety independently.

Methods

App Development

Clinicians, researchers, graphic designers, and software engineers collaborated to create the app called Virtual Wheelchair Coach. Researchers and clinicians reviewed existing educational materials, adapted the content for wheelchair users, and converted the content into a user-friendly format for a smartphone. The interface guidelines for iPhone app developers ("iOS Human Interface Guidelines,") was used to develop the prototype. Additionally, graphic designers often create illustrations to make the materials easy to understand (Van Merriënboer & Sweller, 2010). Therefore, videos were created and included in the Virtual Wheelchair Coach to demonstrate wheelchair skills and wheelchair maintenance. Menus, buttons, pages, links, and content organization were arranged to allow users to quickly locate information within the app. Wheelchair users and clinicians were invited to review the prototype and provide feedback to improve the interface design and content throughout the development phase.

App Content

The Virtual Wheelchair Coach app was divided into the following sections: Getting a Wheelchair, Using Your Wheelchair (Wheelchair Fit and Skills), Maintenance (Wheelchair Maintenance), Health Issues, and Reviews (Consumer Reviews of Wheelchairs). For each section, most essential elements of information were selected based on recommendations from clinicians and wheelchair users. Evidence-based educational materials from credible sources, including United Spinal Association, the Model Systems Knowledge Translation Center, and Wheelchair Skills Training Program led by Dr. Lee Kirby (Kirby, Smith, Parker, MacLeod, & McAllister, 2014), etc., were used to compose the app content. All attempts to keep the content succinct was made in order to prevent consumers from becoming overwhelmed by an excess of information, while providing links for those who wish to access additional detail or further advance their knowledge of the topic. Embedded in the app are interactive components including checklists with the ability to set reminders for scheduled steps in the service delivery process and wheelchair maintenance and the capacity to take notes and photos during the visit or to send photos of a wheelchair

issue to a clinician or wheelchair supplier. The interactive processes were designed to facilitate users to reflect on their own condition and to take action. The app will present specific information about manual and power wheelchairs in the sections of Using Your Wheelchair and Maintenance based on whether the users indicated themselves as a manual or power wheelchair user at the beginning when setting up the app.

Studies

A series of survey studies have been conducted to gather feedback and comments from real wheelchair users and clinicians about the content and app interface design, as well as users' experience in getting a new wheelchair (Liu, Crytzer, Kelleher, Wolff, & Ding, 2015a, 2015b). The surveys were developed by the clinicians and engineers of this app development project to tailor the features and target users of the app. The IBM Computer Usability Satisfaction Questionnaires was an important reference to develop the survey questions to investigate user satisfaction (Lewis, 1995). A usability study is planned and will involve providing the app to participants who have initiated the process of obtaining a wheelchair in order to understand whether the Virtual Wheelchair Coach is useful for the consumer and whether it facilitates consumers to take action to advocate for their needs, manage their health, and improve their wheelchair usage and maintenance.

Preliminary Results

Based on the comments from the wheelchair users who participated in our survey studies, eight out of 20 participants were very satisfied with the process of getting their new wheelchair, while others had significant problems, including improper wheelchair fitting and long waits in the funding process. Participants reported poor or no follow-up service after receiving the new wheelchair. Preliminary results involved five wheelchair users who have reviewed the Getting a Wheelchair section and the supplementary functions on their personal smartphone. Participants reported that the app content will be beneficial for novice wheelchairs to know what to expect in the process and how to prepare for their first visit with healthcare professionals and wheelchair suppliers.

About this Course

The goal of the Virtual Wheelchair Coach app is to disseminate the educational information to wheelchair users. In this instructional course for ISS 2017, the instructors will utilize the app content as a map of key information about wheelchair service delivery, usage and health that novice wheelchair users and therapists need to know to make the best use of their wheelchairs; and introduce online resources providing high-quality, and evidence-based materials about wheelchairs and the service delivery process. We hope that clinicians and suppliers can use the course material as a starting point to ensure novice wheelchair users know about the basic function and effective usage of wheelchairs; what to expect in the process of getting a new wheelchair; and, motivate them to take further action to better understand and gain the skills needed to improve their independence and quality of life.

References

1. Arledge, S., Armstrong, W., Babinec, M., Dicianno, B. E., DiGiovine, C., Dyson-Hudson, T., . . . Rosen, L. (2011). RESNA Wheelchair Service Provision Guide. Retrieved from <http://www.resna.org/sites/default/files/legacy/resources/position-papers/RESNAWheelchairServiceProvisionGuide.pdf>
2. Arva, J., Schmeler, M. R., Lange, M. L., Lipka, D. D., & Rosen, L. E. (2009). RESNA position on the application of seat-elevating devices for wheelchair users. *Assistive Technology*, 21(2), 69-72.
3. Dicianno, B. E., Arva, J., Lieberman, J. M., Schmeler, M. R., Souza, A., Phillips, K., . . . Betz, K. L. (2009). RESNA position on the application of tilt, recline, and elevating legrests for wheelchairs. *Assistive Technology*, 21(1), 13-22.
4. DiGiovine, C., Berner, T., Betz, K., Roesler, T., & Schmeler, M. (2012). RESNA position on the application of ultralight manual wheelchairs. *Rehabilitation Engineering & Assistive Technology Society of North America*. Dunaway, S, 576-582.
5. Free, C., Phillips, G., Watson, L., Galli, L., Felix, L., Edwards, P., . . . Haines, A. (2013). The effectiveness of mobile-health technologies to improve health care service delivery processes: a systematic review and meta-analysis. *PLoS Med*, 10(1), e1001363.
6. iOS Human Interface Guidelines. Apple Developer. Retrieved from <https://developer.apple.com/ios/human-interface-guidelines/>
7. Kirby, R. L., Smith, C., Parker, K., MacLeod, D. A., & McAllister, M. (2014). Wheelchair Skills Training Program (WSTP Manual). Wheelchair Skills Program (WSP) Version 4.2. Retrieved from http://www.wheelchairskillsprogram.ca/eng/documents/WSTP_Manual_4.2.8.pdf
8. Krantz, O., Edberg, A.-K., Persson, D., & Reg, O. (2011). The experience of active wheelchair provision and aspects of importance concerning the wheelchair among experienced users in Sweden. *Review of Disability Studies: An International Journal*, 7, 21-37.
9. Krebs, P., & Duncan, D. T. (2015). Health app use among US mobile phone owners: a national survey. *JMIR mHealth and uHealth*, 3(4).
10. Lewis, J. R. (1995). IBM computer usability satisfaction questionnaires: psychometric evaluation and instructions for use. *International Journal of Human-Computer Interaction*, 7(1), 57-78.
11. Liu, H. T., Crytzer, T. M., Kelleher, A., Wolff, J., & Ding, D. (2015a). Consumer Experiences in Wheelchair Service Delivery Process: Preliminary Findings from an Interview Study. Paper presented at the International Seating Symposium, Nashville, TN.
12. Liu, H. T., Crytzer, T. M., Kelleher, A., Wolff, J., & Ding, D. (2015b). Qualitative Study on Customer Experience in Wheelchair Provision Process: Preliminary Findings for Developing a Mobile App for Consumers to Navigate the Wheelchair Provision Process. Paper presented at the Rehabilitation Engineering & Assistive Technology Society of North America Annual Conference, Denver, CO.
13. Lorig, K. R., & Holman, H. R. (2003). Self-management education: history, definition, outcomes, and mechanisms. *Annals of behavioral medicine*, 26(1), 1-7.
14. Van Merriënboer, J. J., & Sweller, J. (2010). Cognitive load theory in health professional education: design principles and strategies. *Medical education*, 44(1), 85-93.
15. Warsi, A., Wang, P. S., LaValley, M. P., Avorn, J., & Solomon, D. H. (2004). Self-management education programs in chronic disease: a systematic review and methodological critique of the literature. *Archives of Internal Medicine*, 164(15), 1641-1649.

IC77: Keep Calm and Evac On!

Kathryn Fisher, BS OT

Jim Closs

Emergency evacuation of disabled individuals is a difficult undertaking without the proper planning and forethought. Many disciplines are involved including emergency preparedness, occupational health and safety, occupational therapy and perhaps safety and security. Schools and Childrens' Hospitals/Treatment Centres present even a greater challenge when it comes to the duties and responsibilities of getting children with physical disabilities safely out of the classroom.

There have been incidents of students being left in schools during emergency evacuations both in the USA and Canada. In 2013 a New York high school left two students who use wheelchairs behind in a third floor classroom while the remainder of the school buildings were evacuated. The evacuation was due to a fire and was not a fire drill (NBC New York February 2013). Similar events have recently occurred in educational facilities in Nova Scotia, Canada (CBC News Nova Scotia January 2013) and Chicago, United States (CBS Chicago April 2012). These incidents highlight the need for facilities to be prepared with education, experience and equipment.

Training must be implemented to ensure a safe transfer out a building during a crisis including a stairway descent. Techniques must be identified to ensure that the transfer of a disabled student/patient onto evacuation equipment (evacuation chair) is safe for both the client and staff. Once on the chair appropriate positioning of the student/patient and use of safety straps must be determined to ensure safe travel out of the building. Consideration must be made for how and when to get the individual's wheelchair out of the building so they will have a place to sit following the evacuation.

This presentation will review the planning process and training involved with the safe transfer out of a building during a crisis including stairway descent. Transfer techniques and positioning of children and young adults with physical disabilities onto equipment for evacuation will be highlighted.

Evacuation preparedness is at the forefront of safety procedures. Consideration for the specific needs of disabled children and young adults must be clearly addressed while ensuring that staff involved are adequately trained to ensure the safety efficiency of the procedure.

IC78: Car Seats and Vehicular Transport for Children with Special Needs

Amber Yampolsky, PT, ATP, CPST

Erin Baker, PT, ATP, CPST

When seating and positioning is mentioned equipment specialists commonly go straight to a wheelchair or other seating for mobility or home use. A frequently overlooked area and one that can be a matter of life and death is seating and positioning within the family vehicle. Many children with special needs have custom wheelchairs to provide adequate postural support but are then placed either in a standard car restraint or a less than ideal commercial child restraint. What many families are unaware of is the variety of special needs seats ranging from infant style seats to harnessed boosters and beyond that are available to provide their child with the needed and necessary postural support and protection to ensure safety during transportation in the family vehicle. The knowledge gap can be decreased by ensuring that clinicians who are recommending and providing equipment think outside the “chair” and take seating and positioning on the road.

Federal Motor Vehicle Safety Standard 213 regulates design and performance of child restraints however their testing does not take into account that children with special needs will move and respond differently in the event of a motor vehicle accident. Crash testing is completed with test dummies that represent a typical child and dummies that represent a child with special needs have not been studied.

There have been many recent advances in commercially available car seats that allow children with special needs to be transported safely. However, shopping and appropriate selection are much more important when trying to accommodate the child with special needs. When this is not the case, a special needs or adaptive car seat should be used to maintain the safest and best position possible for the child to ensure airway protection, head and neck protection, management of body and muscle tone abnormalities, and keeping the child in the car seat if they have cognitive impairments or behavior issues. There are a variety of special needs car seats on the market to meet different needs including: recline for head and trunk control, supports for postural protection, alternative securement for escape artists, and size for extended use as the child grows. Many rehab and equipment professionals are unaware of the options available and what these pieces of equipment can provide to protect children with special needs during transport. This course will provide education on what child restraints are available today, what benefits they each can offer, and how to go about selecting and acquiring a special needs car seat.

Several steps will be presented for the process of determining the most appropriate child restraint for transporting a child with special needs. The first step in selection of a car seat for any child is understanding the state law as well as the recommendations from the American Academy of Pediatrics. This will help to determine the minimal requirements regarding seat options (ie. Rear versus forward facing, 5-point harness versus booster seat, booster seat versus vehicle seat belt only). The second step is to gain knowledge about the type of vehicle that will be transporting the child. If there are multiple family vehicles, it will be important to take into consideration a seat that will work in all of the vehicles if possible. Step three is selection of the car seat based on the needs of the child. Trialing the child in the restraint is invaluable whenever possible. An important part of this process is that the provider be knowledgeable about the products available or can refer to an appropriately trained person.

There is limited awareness about the programs and persons who are specially trained in the area of child passenger safety, and specifically for children with special needs. Specialized training is necessary to ensure that those providing recommendations on both standard and adaptive car seats are knowledgeable in car seat installation, the variety of available child restraints, and options for accommodating children with special needs within approved safety guidelines. Standard child passenger safety training is available nationwide through Safe Kids Worldwide. Additionally, there are trainings specific to transporting children with special needs. It is important to be aware of trained persons available in your area.

References

1. O'Neil J, Bull M.J, Sobus K. (2011). Issues and Approaches to Safely Transporting Children with Special Healthcare Needs. *J Ped Rehab Med*, 4(4), 279-288.
2. National Child Passenger Safety Board. (n.d.). https://urldefense.proofpoint.com/v2/url?u=http-3A__cpsboard.org_&d=CwIDaQ&c=X2IGR6v8ax_mLhSmU1r3Aw&r=E-rRL-twFAGnJyixqXQzhysSuVc3CuwJu1_K_qw5UHA&m=jkyZVnOeNrShnJEtEIFjzBw9YsXqI_BT6mMkrGqm38s&s=uR933GHZUUFN7jAfPEwbmUMvpmxqHgEwmmwYp6FfnfM&e=
3. O'neil, J, Yonkman, J, Talty, J, & Bull, M. J.. (2009). Transporting Children With Special Health Care Needs: Comparing Recommendations and Practice. *Pediatrics*, 124(2), 596-603. doi:10.1542/peds.2008-1124

IC79: Assistive Technology Collaboration Between Occupational Therapists and Speech Language Pathologists in the Adult Rehabilitation Setting

Amy Grace, OTR/L

Megan Case, MA, CCC-SLP, ATP

Introduction:

The field of Assistive Technology provides many opportunities for a multidisciplinary approach, including collaboration between Occupational Therapists and Speech Language Pathologists. Implementing a collaborative approach in the provision of AT services, allows for more effective service delivery and improved client outcomes and satisfaction with AAC and access devices. Collaboration within the Assistive Technology Center, and in adult rehabilitation settings have resulted in improved success with client implementation of their devices in the home and community environments, due to specialized equipment evaluation, service delivery, training and follow up interventions. Case studies will be presented to provide an overview of Assistive Technology models of service delivery, assessment variables, process of OT, SLP specialized evaluations as well as clinical application of OT, SLP collaboration for AAC, custom wheelchair evaluation, and implementation for the neurologic populations that are served on a daily basis.

Occupational Therapists participate as an active team member within the Assistive Technology Center. The OT's role in evaluation may include needs assessment for client's with changes in wheelchair seating/positioning equipment, access for new power mobility equipment and technology, visual-perceptual or motor deficits, and identification of alternative access/AAC needs. (1) Collaboration with the SLP can occur during the provision of AAC or access devices, when the client's needs for visual-perceptual, motor, postural seating equipment are identified during functional evaluations. OT's participate with SLP and the client to provide trials of AAC selected equipment, switch access, observation of visual-perceptual, motor skills, assessment of functional seated positions, recommendations for new equipment/technology. The collaboration with SLP occurs in all phases of service delivery and includes implementation, follow up and follow along within the AT Center.

Speech Language Pathologists participate as an active team member within the AT Center. The SLP's role in evaluation may include needs assessment for client's with communication impairments, search for updated (AAC) technology, consideration for alternative access,

transitional client (adolescent to adult). (3,5) The SLP evaluation for AAC and communication impairment allows for collaboration with OT to address cognitive abilities, visual/sensory skills, postural and mobility status. The SLP provides services within the AT Center to client's with a variety of wheelchair seating equipment/technology. The SLP conducts a comprehensive evaluation of communication needs and AAC suitability, after which allows for OT collaboration during trials of AAC switch access, AAC mounting options, effectiveness of functional seated positions, and recommendations for new equipment/technology use. The collaboration with OT occurs in all phases of service delivery and includes implementation, follow up and follow along within the AT Center.

Methods:

This presentation will address use of common evaluation methods for OT, SLP (1, 5), AT models and service delivery (1), feature matching of AAC (3,5), custom wheelchair seating equipment (2,4) and access methods for switch use as applicable to the outpatient adult rehab setting. AT assessment variables are a key component of evaluation and service delivery when providing treatment to adult neurologic populations with complex wheelchair seating and communication needs. Examples of assessment variables will include the consumer and community partner(s) with AT Specialist for 2 clients: Amyotrophic Lateral Sclerosis (ALS), and Spastic Cerebral Palsy (CP).

Case Study (ALS):

- Client background (39 yo male, onset 12 yrs, progressive motor weakness, dysarthria, not working)
- Body Systems and Structures (nonfunctional UE (1/5 strength), nonambulatory, Rt foot active control WFL, progressive dysarthria, cognitive intact)
- Activity/ Capacity (dependent ADL's, relies on others for communication, maximal assist for IADL-phone, computer, iPad)
- Participation/Performance (currently resides with fiancée, dependent ADL, not working, attends ALS support group, community events, future mobility, communication needs will change with progression of ALS)
- Environment (devices will be used in home and community, OT/SLP will participate in set up of w/c, SGD, training, follow up, follow along)
- Clinical Trials/Simulation (SGD- Tobii 1-12, eye gaze, Permobil power wheelchair, alternate foot controls)
- Implementation Plan (return to At Center for delivery, customization, training, incorporate vendor for equipment adjustments, follow up, follow along within clinic settings)

Case Study (Spastic CP):

- Client Background (31 yo male, Spastic CP at birth, G-tube feedings, reactive airway disease, impaired mobility, postural instability, flexion contractures of UE, LE)

- Client Goals (explore high tech communication, evaluate for SGD access, review w/c equipment needs)
- Existing or Prior AT devices (low tech communication board, manual tilt in space w/c, pressure relief cushion, full arm tray, stroller used as transport chair (no custom seating))
- Body Systems and Structures (nonambulatory, dependent propulsion, fluctuating head, trunk control, increased UE, LE spasticity, oral motor impaired, vision and cognitive intact)
- Activity/ Capacity (dependent ADL's, relies heavily on others for communication, maximal assist for IADL-computer, TV remote)
- Participation/Performance (currently resides in private home with roommate, 24 hr caregivers, dependent ADL, works at Goodwill, active in sports card collecting, planning social events, future-mobility, communication, access for more indep in ADL)
- Environment (devices will be used in home and community, OT/SLP will participate in set up of access devices for w/c, SGD, training, follow up, follow along)
- Clinical Trials/Simulation (SGD- alternative access with direct selection, keyguard, scanning with single buddy switch (head), mounting trials -loc line for flexible mount, incorporate vendor for mounting options)
- Implementation Plan (return to At Center for delivery, customization, training, incorporate vendor for equipment adjustments, follow up, follow along within clinical settings)

Conclusion

Effective implementation of AAC, access devices, and custom wheelchair seating equipment has been successfully demonstrated with a collaborative approach between OT and SLP. Ensuring comprehensive and multidisciplinary evaluation, implementation, education and follow through methods allows for effective client outcomes, satisfaction, and functional application of the AT recommended equipment.

References

1. Cook, A., Hussey, S., & Polgar, J.M. (2008). *Cook and Hussey's Assistive Technology Principle and Practice*. St. Louis, Missouri: Mosby, Inc.
2. Costigan, F A., & Light, J. (2010). Effect of Seated Position on Upper-Extremity Access to Augmentative Communication for Children with Cerebral Palsy: Preliminary Investigation. *AJOT*, 64, 596-604. Retrieved online from: <http://ajot.aota.org>
3. Gibbons, C., Beneteau, E., (2010). Functional Performance Using Eye Control and Single Switch Scanning by People with ALS. *Perspectives on Augmentative and Alternative Communication*. 19(3), 64-69. Retrieved online from: <http://sig12perspectives.pubs.asha.org>
4. Mac Neela, J. C. (1987). An overview of therapeutic positioning for multiply -handicapped persons, including augmentative communication users. *Physical and Occupational Therapy in Pediatrics*, 7, 39-60. Retrieved online from: <http://unboundmedicine.com>
5. Helling, Celeste R. (2014). Developing an Effective Framework for the Augmentative and Alternative Communication Evaluation Process. *SIG 12 Perspectives on Augmentative and Alternative Communication*. Vol. 23, 91-98. Retrieved online from: <http://sig12perspectives.pubs.asha.org>

IC80: Expanding Roles of Therapist Assistants and Wheelchair Provision

Sheilagh Sherman, BA, BHScOT, MHM

Due to tight healthcare budgets, the role of the therapist assistant, and the clinical settings in which the assistant works, are expanding. While not replacing prescribing therapists, assistants provide support in all the steps of wheelchair provision – from referral through to discharge. Based on an informal survey of occupational therapists and physiotherapists working in seating and mobility in Canada in clinical settings ranging from acute care to community care to long-term care/complex continuing care to seating clinics, this paper describes the support that assistants provide and the themes that emerged related to supervision of support personnel in seating and mobility. The themes, which included communication, collaboration, knowledge base and skills development, are well represented in the literature regarding therapist assistants.

Administration/Referral

Depending upon the clinical setting, a therapist assistant may be assigned some administrative duties. In a seating clinic, the rehab assistant may be responsible for booking appointments, which includes scheduling the therapist, client, vendor and any other required individuals at a time that is convenient for all. The rehab assistant may order charts and obtain other background information required by the therapist for the assessment. After the completion of the assessment, the therapist assistant may contact the vendor to request equipment for trial, as specified by the therapist.

In long-term care, some facilities may contract or employ therapists on a part-time basis, ranging from a specified number of hours weekly or monthly, depending upon the size of the facility. These same facilities may employ rehab assistants on a full-time basis. In this situation, the therapist assistant may be responsible for initiating a referral to a therapist for a seating and mobility assessment when a client requires a mobility device so that the therapist is aware of this upon the next visit. Likewise, the therapist assistant may be the point of contact for family members and other staff regarding mobility devices between the scheduled visits of the therapist and may notify the therapist when an assessment or intervention is needed.

Assessment

Whether in acute care, long-term care, inpatient rehabilitation or seating clinic, rehabilitation assistants provide much assistance for seating and mobility assessments. In seating clinics, an OTA/PTA prepares the clinic prior to each appointment and cleans between appointments. In addition, the therapist assistant may assist with custom shape captures at a seating clinic. In long-term care, the

therapist assistant may be able to provide the therapist with relevant background information regarding the client, such as usual method of propulsion, transfers, and postural history. In settings where the therapist visits the facility weekly or monthly, having the rehab assistant involved in the assessment allows the assistant to be part of the process and to be informed of the requirements as the assistant tends to be the liaison between the client/family, vendor and therapist.

In all settings, a rehabilitation assistant may assist when a second person is required. For example, an OTA/PTA may assist with transfers or the use of a mechanical or ceiling lift; may help to support an individual with poor sitting balance or unpredictable tone during the assessment; and may take required photos. For individuals who are on isolation or infection precautions, the rehab assistant can act as the “clean” person during the assessment, being the scribe and note-taker for the therapist.

Equipment Provision and Trial

The clinical setting influences the type and amount of involvement of a therapist assistant in equipment provision. In some settings, such as inpatient settings and some long-term care/complex continuing care settings, the facility has an equipment pool of wheelchairs, cushions and back supports. Sometimes, a therapist assistant provides a temporary wheelchair until the therapist returns to the facility to conduct an assessment to prescribe a more permanent seating and mobility system for a client, such as in long-term care. In some settings, such as acute-care, inpatient rehab, and complex continuing care, the therapist assistant sets up a wheelchair with seating and accessories, such as a lap tray, from equipment pool choices, as specified by the therapist. Adjustments to the set-up are made by the assistant, as directed by the therapist.

When equipment is being trialed for prescription purposes, the setting and the province (i.e., availability of equipment through funding programs) influences the responsibilities of the rehab assistant. At a seating clinic, the therapist assistant may be responsible for installing seating components onto a mobility base or making adjustments to a wheelchair to set it up for trial and/or fittings. The assistant may pre-wrap equipment, if required for infection control precautions.

At a long-term care facility, a therapist may or may not be present when new equipment arrives for a client, depending upon scheduling. If the therapist is not present, the therapist assistant and vendor may set up the client with the new equipment until the therapist's next visit, when adjustments can be made/arranged. If both the therapist and therapist assistant are present when the new equipment arrives, the therapist may assign follow up to the rehab assistant for recommended changes that can be made by the vendor without the presence of the therapist. The assistant, because she has been part of the initial fitting and understands the rationale, can follow up with the vendor as the go-between for the therapist and vendor when the therapist works only part-time at a facility. Particularly when a therapist does not work full-time at a centre, the rehab assistant has a vital role in reporting back to the therapist how the wheelchair trial is progressing for the client with information on issues such as comfort, posture, or sliding.

Pressure mapping is another area where rehab assistants provide assistance. Therapist assistants set up the pressure mapping system in preparation for appointments when pressure mapping will be used to evaluate seating.

Training

Therapist assistants provide much support in the area of mobility training. Whether it is in acute care, inpatient rehab, long-term care/complex continuing care or seating clinic, rehab assistants often are assigned mobility training with clients. From basic wheelchair safety and mobility in acute care or long-term care to manual wheelchair skills in inpatient rehab to power mobility training over several visits in the community, rehab assistants play a role in assisting clients to learn the required skills and in reporting back to the therapist on client progress. Checklists may be used to ensure all areas of training are covered; for example, accessing transportation in the community. Training may be provided in how to remove/fold some wheelchair components for a transfer. Therapist assistants may provide training to clients in areas such as cushion maintenance (e.g. how to check inflation of an air cushion) and wheelchair maintenance (e.g., how and when to charge batteries on a power wheelchair). In addition, therapist assistants provide informal training. For example, assistants may provide clients with safety reminders regarding wheelchair use when the therapist is not on-site and will advise the therapist of any safety concerns noted when the therapist is not present in the facility.

Funding

A rehab assistant may assist in completing sections of funding applications. Depending upon the funding agency requirements, a therapist assistant may call for price quotes on equipment. The rehab assistant may be assigned administrative duties and be responsible for submitting/faxing completed paperwork to funders or other agencies.

Equipment Maintenance/Inventory Management

OTAs/PTAs may be responsible for seating and mobility equipment and related inventory management. In larger facilities, this role becomes specialized, with one person assuming primary responsibility and gaining expertise in this area. Often, the job title reflects this expertise, such as “wheelchair technician”.

Therapist assistants are responsible for organizing equipment pools, cleaning and disinfecting equipment, and performing basic repairs. Therapist assistants also may be responsible for charging power wheelchairs and performing maintenance checks on equipment being returned to the equipment pool. In some long-term care facilities, therapist assistants are responsible for submitting funding requests for vendors to complete more complex repairs.

Communication

Communication is an important element in the provision of wheelchairs, no matter the clinical setting. When looking at the role of therapist assistants in wheelchair provision in long-term care settings, being the contact person and relaying communication from the client, family and nursing staff to the therapist upon his or her next visit is one of the duties when a therapist is employed part-time in a facility.

In some settings, the therapist assistant is involved with multiple aspect of the treatment plan, as assigned by an occupational therapist and/or physiotherapist, and therefore spends more time with the client than the therapist who is overseeing the treatment program. Sometimes the rehabilitation assistant can get the “real” feedback from the client on the wheelchair trial. Perhaps the client is uncomfortable sharing negative feedback about the seating and wheelchair with the therapist, but are more willing to share their honest opinion with the OTA/PTA as they spend more time with the therapist assistant.

In the article “Occupational therapist assistants: Enabling well-being in community power mobility users”, the authors, Gillespie and Engel, stated that “there may be a decreased perceived authority differential between the client and the OTA compared to the occupational therapist, and this can foster a good therapeutic relationship.” (2015, p. 9). The decreased perceived authority differential may be another reason why a client may be more willing to give the “real” feedback on the wheelchair trial to an OTA/PTA, rather than an occupational therapist or physiotherapist.

Methods and frequency of communication will vary depending upon the practice setting. For example, in the community, communication on client progress occurs through documentation in the client record and through voicemail and email updates to the supervising therapist, when face-to-face communications may be more difficult to plan. An innovative practice described in the literature is the use of iPads to communicate within a large hospital setting. (Feenstra & Grouchy, 2015.) This allows for immediate communication between the therapist and therapist assistant, using the texting feature to share information and even using the video conferencing feature to problem-solve issues, such as equipment needs, in real time.

Collaboration

When describing the role of the therapist assistant in wheelchair provision, some therapists have described the rehabilitation assistant as being a collaborator in the process. For example, in acute care, the therapist and therapist assistant may select a wheelchair together from amongst available equipment pool choices if there were difficulties with the original piece of equipment provided from the equipment pool. Due to the complexity of some seating and mobility systems, having someone with whom to bounce ideas can be beneficial.

Collaborative relationships between therapists and therapist assistants have also been described in the literature. Collaboration between the occupational therapist and OTA, in which both skills and knowledge were combined, enabled

enhanced service delivery (Gillespie & Engel, 2015), which benefits the client. "OTAs provide another pair of eyes and hands to assist the occupational therapist to recognize concerns and promote engagement in occupation. The relationship between occupational therapist and OTA is more than the assignment of a task. It requires trust, understanding, an exchange of ideas and working together to provide the best care for the client." (McCready-Wirth et al., 2015, p. 20)

Knowledge Base

There is a certain level of knowledge or skill required of the therapist assistant to work in the area of seating and mobility. Orientation and mentoring by experienced therapist assistants, on-the-job training, and on-going education in seating and mobility through attendance at in-services, workshops and conferences were considered important to gain the knowledge and skill required to work in this area. It was noted that when a therapist assistant develops the necessary expertise to work in seating and mobility, greater efficiencies can result. For example, in some inpatient rehabilitation settings, it is more efficient to have one rehabilitation assistant be responsible for the seating and wheelchair pool and setting up wheelchairs for inpatients, rather than having several assistants share the responsibility.

Summary

The role of the therapist assistant in wheelchair provision is expanding. Rehab assistants can support therapists by completing administrative and clerical duties. OTAs/PTAs can assist during the assessment, by providing another set of hands for safety or for documentation purposes. Therapist assistants have a large role to play in equipment provision and set-up, in addition to client training with mobility devices and transfers. Rehab assistants also tend to become responsible for maintaining equipment pools and managing inventory. Therapist assistants have a role to play to assist therapists and clients in all of the steps of wheelchair provision, from assessment through to discharge, and from acute care to long-term care and every setting in-between.

The knowledge required for the role will vary depending upon the clinical setting in which the therapist and therapist assistant work. For example, some rehabilitation assistants will gain expertise in seating and mobility to allow for greater efficiencies in service delivery. Collaboration between therapists and therapist assistants also allow for enhanced service delivery when knowledge and skills are shared for the benefit of clients. No matter the setting, communication between the client, therapist and therapist assistant are important in achieving the goals of wheelchair provision.

References:

1. Gillespie, H., & Engel, L. (2015, March/April). Occupational therapist assistants: Enabling well-being in community power mobility users. *Occupational Therapy Now*, 17(2), 8-10.
2. Feenstra, C., & Grouchy, N. (2015, March/April). Communication: From low tech to high tech. *Occupational Therapy Now*, 17(2), 15.
3. McCready-Wirth, A., Hepting, C., Ng, W., Haney, C., Bratkoski, L., & MacAusland-Berg, D. (2015, March/April). On the road together: Community occupational therapists and occupational therapist assistants working to provide the best care. *Occupational Therapy Now*, 17(2), 19-20.

Conflict of Interest Disclosure

The author works full-time for Sunrise Medical Canada as a Clinical Educator; however, the topic of this presentation does not relate to seating and mobility products.

PS10.1: Changes in EEG Spectra in Response to Power Mobility Training

Lisa K. Kenyon PT, DPT, PhD, PCS

John Farris, PhD

Samhita Rhodes, PhD

Naomi J. Aldrich, PhD

Background:

Children who have multiple, severe disabilities are typically unable to crawl or walk and therefore may have difficulties attaining the developmental experiences inherent in independent locomotion (Anderson et al., 2013; Campos et al., 2000). Recent research suggests that power mobility training may provide beneficial learning opportunities for these children even though they may never become independent, community drivers (Kenyon et al., 2015; Kenyon et al., 2016; Livingstone & Paleg, 2014; Nilsson & Nyberg, 2003; Nilsson, Nyberg, & Eklund, 2010; Nilsson, Eklund, Nyberg, & Thulesius 2011). The purposes of this pilot project were as follows: (1) to evaluate the impact of power mobility training with children who have multiple, severe disabilities and (2) to determine if participants' spectrum of electroencephalography (EEG) activity changed during the course of power mobility training.

Method:

A multiple baseline, single-subject design with repeated measures was used in this study. The A-B-A-B study design was divided into baseline (A) and intervention (B) phases with a 5-week duration for each phase and a total study length of 20-weeks. A single retention trial was conducted 6-weeks after the conclusion of the 20-week study to determine the participants' retention of power mobility skills.

Inclusion criteria for the study were as follows: (1) a diagnosis of cerebral palsy (CP) at a Gross Motor Function Classification System (GMFCS; Palisano, Rosenbaum, Bartlett, & Livingston, 2008) Level IV or V; (2) manual ability classified as a Level IV or V on the Manual Ability Classification System (MACS; Eliasson et al., 2006); (3) have a manual wheelchair or adaptive stroller that was appropriate in fit and function that could be safely used in conjunction with an alternative power mobility device; (4) ages 3-12 years; (5) parental/guardian permission to participate in the study; and (6) assent to participate in the study (if applicable).

The Dimensions of Mastery Questionnaire (DMQ; Morgan, Busch-Rosnagel, Barrett, & Wang, 2009) was administered each week and weekly electroencephalography (EEG) data was recorded under various conditions. Additional outcome measures included the Canadian Occupational Performance Measure (COPM; Law et al., 2014), the Assessment of Learning Power mobility use (ALP; Nilsson & Durkin, 2014), the

Wheelchair Skills Checklist (WSC; Butler, Okamoto, & McKay, 1984), and a qualitative maternal interview. During intervention phases, children participated in individualized power mobility training activities.

Results:

At the completion of the final intervention phase, all participants demonstrated significant improvements on the COPM, ALP, and WSC and slight to moderate progress on some, but not all, aspects of the DMQ. Themes within the maternal interview revealed mothers' positive perceptions related to power mobility training for their child. Despite these positive changes in function, changes in the EEG spectra were variable and open to interpretation.

Discussion:

The participants in this pilot project demonstrated improvements in power mobility skill and function as assessed through the COPM, ALP, and WSC.

Conclusion:

Additional research is needed to further investigate the potential of EEG to provide beneficial insights into the impact of power mobility use in children who have multiple, severe impairments.

References:

1. Anderson, D.I., Campos, J.J., Witherington, D.C., Dahl, A., Rivera, M., He, M., ... Barbu-Roth, M. (2013). The role of locomotion in psychological development. *Frontiers in Psychology*, 4:440. doi: 10.3389/fpsyg.2013.00440
2. Butler, C., Okamoto, G.A., & McKay, T.M. (1984). Motorized wheelchair driving by disabled children. *Archives of Physical Medicine and Rehabilitation*, 65(2):95-97.
3. Campos, J.J., Anderson, D.I., Barbu-Roth, M., Hubbard, E.M., Hertenstein, M.J., & Witherington, D. (2000). Travel broadens the mind. *Infancy*, 1(2):149-219.
4. Eliasson, A.C., Krumlinde-Sundholm, L., Rösblad, B., Beckung, E., Arner, M., Ohrvall, A.M., & Rosenbaum, P. (2006). The Manual Ability Classification System (MACS) for children with cerebral palsy: scale development and evidence of validity and reliability. *Developmental Medicine and Child Neurology*, 48(7):549-554.
5. Kenyon, L.K., Farris, J., Brockway, K., Hannum, N., & Proctor K. (2015). Promoting self-exploration and function through an individualized power mobility training program. *Pediatric Physical Therapy*, 27(2):200-206.
6. Kenyon, L.K., Farris, J.P., Gallagher, C., Hammond, L., Webster, L.M., & Aldrich, N.J. (2016). Power mobility training for young children with multiple, severe impairments: a case series. *Physical and Occupational Therapy in Pediatrics*, 1-16. doi:10.3109/01942638.2015.1108380.
7. Law, M., Baptiste, S., Carswell, A., McColl, M.A., Polatajko, H., & Pollock, N. (2014). *Canadian Occupational Performance Measure*, 5th ed. Ottawa, Canada: CAOT Publications ACE.

-
8. Livingstone, R., & Paleg, G. (2014). Practice considerations for the introduction and use of power mobility for children. *Developmental Medicine and Child Neurology*, 56(3):210-232.
 9. Morgan, G.A., Busch-Rossnagel, N.A., Barrett, K.C., & Wang, J. (2009). The Dimensions of Mastery Questionnaire (DMQ): a manual about its development, psychometrics, and use. Retrieved 8 March 2015 from [http://www.mychs.colostate.edu/gmorgan/docs/DMQmanual\(05-11-2009\).pdf](http://www.mychs.colostate.edu/gmorgan/docs/DMQmanual(05-11-2009).pdf).
 10. Nilsson, L.M., & Nyberg, P.J. (2003). Case report—driving to learn: a new concept for training children with profound cognitive disabilities in a powered wheelchair. *American Journal of Occupational Therapy*, 57(2):229-233.
 11. Nilsson, L., Nyberg, P., & Eklund, M. (2010). Training characteristics important for growing consciousness of joystick-use in people with profound cognitive disabilities. *International Journal of Therapy and Rehabilitation*, 17(11):588-595.
 12. Nilsson, L., Eklund, M., Nyberg, P., & Thulesius, H. (2011). Driving to learn in a powered wheelchair: the process of learning joystick use in people with profound cognitive disabilities. *American Journal of Occupational Therapy*, 65(6):652-660.
 13. Nilsson, L., & Durkin, J. (2014). Assessment of learning powered mobility use—applying grounded theory to occupational performance. *Journal of Rehabilitation Research & Development*, 51(6):963-974.
 14. Palisano, R., Rosenbaum, P., Bartlett, D., Livingston, M. (2008). Content validity of the expanded and revised Gross Motor Function Classification System. *Developmental Medicine and Child Neurology*, 50(10):744-750

Correspondence

Please address correspondence to
Dr. Kenyon at the following e-mail address:
kenyonli@gvvsu.edu

Conflict of Interest Disclosure

We (**Lisa Kenyon, John Farris, Samhita Rhodes, and Naomi Aldrich**) do not have any conflicts of interest to disclose. Specially, none of the authors have an affiliation (financial or otherwise) with an equipment, medical device, or communications organization.

PS10.2: Is Empowering Indoor/Outdoor Mobility Medically Necessary?

Jill Barnett, BSc.

Ron Porter, OT

Tom Lowell

Angus Kinnaird, BA (Hons Psych)

Background

This paper presents the case of Tom, a 51 year old father who contracted ALS around four years ago. Tom's case came to light when he posted on social media about his life transforming experience of receiving a US Medicare funded indoor-outdoor powerchair, highlighting the positive impact on his mental health and wellbeing associated with his liberation from home entrapment.

Tom's case revealed a disconnection between the therapeutic value arising from his regaining outdoors mobility, and the rationale used to justify its medical necessity. This was actually based on Tom's need for an indoor-outdoor powerchair to safely come and go from his home for medical treatments, which necessitated travel over unpaved terrain in his yard. The mental health issues associated with his home entrapment were not even considered as potentially relevant.

This raised questions as to why mental health was not considered as a valid reason for equipping Tom for safe, pain free access to outdoor occupations. Arguably, if not for the wheelchair inaccessible design of his home, Tom may have remained stuck indoors in a mentally depressed state of deteriorating health.

This paper questions the limited view of medical necessity that considers only physical risks associated with mobility inside the home or getting to and from the home. It suggests that potentially costly health risks can arise in home due to a person's limited capacity to travel comfortably and safely within recreational and community environments outside of the home. It explores the potential to justify funding for indoor-outdoor mobility as a medically necessity to reduce health risks such as depression that arise from occupational deprivation associated with home entrapment.

Methods

A single case was explored via in-depth review of an instance in which occupational deprivation associated with inappropriate powerchair mobility appeared to have a negative impact on participant's mental health, which was ameliorated by provision of appropriate indoor-outdoor powerchair technology.

Tom and his prescribing OT Ron were originally approached by the primary author as sponsor of Views from the Chair; a social-media platform that invites wheelchair users and prescribers to speak out about issues associated with appropriate wheelchair provisioning. Each agreed to be interviewed about Tom's provisioning experience. Two interviews were conducted by a professional qualitative researcher to capture Tom and Ron's experiences. With their permission, data obtained through those interviews was used as the basis for the case study. Verbatim transcripts from video footage were used for analysis and reporting. A literature review was also conducted to assess availability of peer-reviewed studies that might support a rationale for the medical necessity of funding appropriate indoor-outdoor powerchair provision based on the need to empower outdoor occupational participation.

Findings

Findings from the case study identified three emergent themes:

1. Inadequate wheeled mobility induced home entrapment that caused adverse mental health and elevated depression;
2. Provision of an indoor-outdoor powered wheelchair empowered community and occupational participation;
3. Empowered community and occupational participation ameliorated mental distress and depression, and enhanced quality of life.

Each theme is now described as it related to Tom's experience.

1. Inadequate wheeled mobility induced home entrapment caused adverse mental health and elevated depression

Tom's life before contracting ALS involved a lot of outdoor activity with his friends and family. After his diagnosis he attempted to remain active outdoors using a powerchair designed for indoor use; however the physical discomfort associated with riding over rough terrain with inadequate tyres and suspension proved physically unbearable, which meant he was effectively limited to living indoors. As Tom explained:

"A normal wheelchair beats you up too much, when you're bouncing around on the gravel on the trails and the paths.... As an ALS patient, you lose core strength and you're unable to anticipate the bumps and move your body accordingly. So you get really beat up and it's very fatiguing. So you end up staying inside all the time".

Being stuck inside all the time distressed Tom. Lack of fulfilling occupational opportunities led him to dwell on his loss of purpose and reduced life expectancy. This undermined his quality of life and mental state to the extent that he lost motivation and became depressed. As he stated:

"The lack of an outdoor wheelchair greatly affected my life. I was getting cabin fever: not getting out and about with my friends and my family, visiting the places that I always loved to visit. ... My knowledge and expertise of the mountains and backwoods was confined to my living room; helplessly locked away in my mind. ...

It really gets depressing, and there just becomes no real point in getting out of bed in the morning when you can't get out and see your friends and go to the places you want to go. You're just left to endure the relentless disease, and not move around at all."

2. Provision of Tom's indoor-outdoor powered wheelchair empowered community and occupational participation

Tom's indoor-outdoor powerchair has minimised the pain and discomfort of outdoor mobility, and enabled him to enjoy many hours of independent outdoors activity involving both recreational and practical occupations:

"With the off-road, all terrain V6 AT it's a softer, plusher ride and you don't feel the bumps like that. It takes the bumps for you. ...

I was able to take it up on the mountain on Saturday and Sunday and do some trail riding, and then on Monday it was still manoeuvrable enough to take it into a corporate setting and then on Tuesday I could take it to the medical facility...

I am once again an athlete, outdoor educator and explorer, a backwoods guide and leader, a member of local search and rescue: and most importantly able to enjoy outings with my loving wife and children."

3. Empowered community and occupational participation ameliorated mental distress and depression, and enhanced quality of life

Tom's ability to exercise his mental and physical capabilities and seek out new and stimulating experiences outdoors has restored his sense of personal achievement and motivation to overcome the deprivations of his disease; a transformation he describes as "night and day":

"The emotional difference since taking delivery of the V6 AT has been [like] night and day. Before, I was house-ridden; not getting out and about. It's really important for your spirit to get out and about...

When you're out, beating your way through the back woods on your V6 AT you're totally in the moment, and your presence of mind, your awareness of your surroundings, it's fully rejuvenating for your spirit and your soul. You really feel like you've been somewhere, you've experienced something. You look back on your day with fondness, and you've made some great memories. It's just that you have a sense of accomplishment.

So the difference is; you don't feel like you're dying, you feel like you're still living."

Ron, Tom's prescribing OT, summarised his assessment of this outcome as follows:

"Being able to access the outdoors greatly improved Tom's mental health, his wellbeing, and perhaps even his longevity with his life threatening disease."

Discussion

Outdoor mobility and mental health

Tom's case study clearly links access to outdoors activities with his better mental health, and conversely links home entrapment with his poorer mental health.

Many studies have reported on the positive life-transforming impact of appropriate powered mobility provision (Evans 2000, Hardy 2004; Schmidt 2014), however none were found that specifically examine the relationship between empowering outdoor mobility and improved mental health. There is, however, published evidence consistent with the hypothesis that home entrapment in cases such as Tom's represents a mental health risk.

People like Tom value quality time spent outdoors with friends and family, and look to mentally challenging outdoors activities for inspiration and self-fulfilment. Lack of outdoor mobility in Tom's case resulted in what Wilcock (2006) describes as occupational deprivation - a condition where one's opportunities to engage in meaningful occupations is diminished due to external controls. Occupational deprivation is clearly aligned to poor health outcomes (Whiteford 2000). Occupational Therapy Australia (2016) concludes that "being prevented from engaging in meaningful occupations can lead to psychological and physical illness, impairment, and reduced productivity".

Tom's occupational deprivation was associated with elevated depression, which has been shown to lead to poorer health and reduced life expectancy in patients with ALS (Thakore & Piro 2016).

There is also evidence that appropriate provision of powered indoor-outdoor wheelchairs significantly improves personal mobility, quality of life and experience of pain and discomfort (Davies 2003), in line with Tom's experience. Research by Chan & Chan (2007) has directly linked enhanced quality of life outcomes associated with appropriate wheelchair provision to enabling consumers' goals to participate physically and socially within their community.

Medical cost necessity

Narrow interpretation of the 'in home' medical necessity criterion imposed by Medicare may reflect the reality that such criteria are used as a way to manage resource constraints; to control supply and provision variations between districts (White & Lemmer 1998). It may be that the resource constrained US Medicare funding environment has effectively framed the concept of medical necessity in a way that downgrades qualitative outcomes such as quality of life and longevity relative to demonstrable medical cost savings. This raises the question as to whether the extra cost of providing an indoor-outdoor wheelchair can be justified in terms of reducing overall costs of medical care.

Researchers Layton & Walker (2012) reviewed the economic rationale for provision of individually tailored powered wheelchairs. Their critique noted that poorly tailored Assistive Technology (AT) solutions not only reduce effectiveness but can also generate negative health outcomes and injuries. They concluded that investment in optimal AT solutions is demonstrated to offset other costs from a health and community services sector perspective. Salatino (2015) estimated that provision of a powered wheelchair generated savings on average of about \$38,000

per person in social costs over a projected 5-year period, compared to non-intervention.

However, it may be difficult to broadly justify the higher cost of providing indoor-outdoor powered wheelchairs in terms of avoiding mental health care costs. It is hard to link these costs directly to wheelchair provision, and they tend to vary widely based on individual circumstances (Layton 2010).

Demonstrating the wheelchair cost effectiveness to avoid home entrapment may require a more specific, case-by-case approach. In Tom's case, the evidence points to three key areas of potential savings:

1. Costs of mental health care for the wheelchair user and his family members;
2. Cost of treating incurred injury and pain management associated with attempts to pursue outdoor occupations using inappropriate indoor powerchair technology;
3. Cost of paid carer or other support required because of the wheelchair user's limited capacity to independently manage medically necessary activities outside of his or her home.

Conclusion

Tom's case study highlights the following assertions, which are broadly supported by available literature:

1. Attempts to pursue outdoors activities in indoor powerchairs are associated with high levels of pain and discomfort, which can lead to home entrapment;
2. Home entrapment due to inappropriate powered mobility can lead to occupational deprivation;
3. Occupational deprivation associated with home entrapment can lead to mental health problems such as depression;
4. In some cases, the medical costs associated with home entrapment may outweigh the incremental cost of indoor-outdoor provision.

These assertions challenge wheelchair prescribers and funders to consider the medical necessity of powered indoor-outdoor mobility in all cases where access to outdoor occupations is important to a person's mental health and wellbeing.

In such cases, we would argue that prescribing therapists should assess the mental health risks of occupational deprivation due to home entrapment in line with their professional duty of care, alongside potential health care savings that may arise from prescribing powered wheelchair mobility in and beyond the home.

More research is needed to clarify when and how provision of an indoor-outdoor powerchairs may be justified as medically necessary to avoid mental health problems and reduce costs of medical care. The idiosyncratic nature of mental health risks and medical care costs means that more case studies like Tom's will be critical as a source of relevant evidence.

References

1. Chan, S., & Chan, A. (2007). User satisfaction, community participation and quality of life among Chinese wheelchair users with spinal cord injury: a preliminary study. *Occupational Therapy International*, 14(3), 123-143.
2. Davies, A., De Souza, L. H., & Frank, A. O. (2003). Changes in the quality of life in severely disabled people following provision of powered indoor/outdoor chairs. *Disability and Rehabilitation*, 25(6), 286-290.
3. Layton, N., & Walker, L. (2012). The economic potential of assistive technology solutions – an introduction. A paper in the ARATA Making a difference with AT services. Australia: ARATA publication. Retrieved from: http://www.arata.org.au/download/NDIS/fullbkgnpapers_v10int.pdf
4. Layton, N., Wilson, E., Colgan, S., Moodie, M. & Carter, R (2010). The equipping inclusion studies: assistive technology use and outcomes in Victoria ; key findings and policy implications. Deakin University, Burwood, Vic.
5. Salatino, C., Andrich, R., Converti, R. M., & Saruggia, M. (2015). An observational study of powered wheelchair provision in Italy. *Assistive Technology*, 28(1), 41-52.
6. Thakore, N., & Piro, E. (2016). Depression in ALS in a large self-reporting cohort. *Neurology*, 86(11), 1031-1038.
7. Evans, R. (2000). The effect of electrically powered indoor/outdoor wheelchair on occupation: a study of users' views. *British Journal of Occupational Therapy*, 63(11), 547-553.
8. Hardy, P. (2004). Powered wheelchair mobility: an occupational performance evaluation perspective. *Australian Occupational Therapy Journal*, 51(1), 34-42.
9. Wilcock, A. A. (2006). An occupational perspective of health. Thorofare, NJ: Slack Incorporated.
10. Occupational Therapy Australia (2016) Position paper: Occupational Deprivation. Retrieved from [http://www.otaus.com.au/sitebuilder/advocacy/knowledge/asset/files/21/positionpaper-occupationaldeprivation\[april2016\]-occupationaltherapyaustralia.pdf](http://www.otaus.com.au/sitebuilder/advocacy/knowledge/asset/files/21/positionpaper-occupationaldeprivation[april2016]-occupationaltherapyaustralia.pdf)
11. Schmidt, R.E. (2014) In-depth case study of Australian seating service experience: stakeholders' perspectives. PhD thesis, School of Health and Social Development, Deakin University, Geelong, Vic. Retrieved from <http://dro.deakin.edu.au/eserv/DU:30074802/schmidt-indepthcase-2015A.pdf>
12. Whiteford, G. (2000). Occupational Deprivation: Global Challenge in the New Millennium. *British Journal of Occupational Therapy* May 2000 vol. 63 no. 5 200-204
13. White, E., & Lemmer, B. (1998). Effectiveness in wheelchair service provision. *British Journal of Occupational Therapy*, 61(7), 301-305.

Authors

Jill Barnett, BSc.

jill@magicmobility.com.au

Jill is General Manager of Magic Mobility and primary sponsor of Views from the Chair, a social media platform that invites wheelchair users and prescribers to speak out about issues associated with appropriate wheelchair provisioning. Jill's support enabled Tom to tell his story, which made this paper possible.

Ron Porter, OT, AOTA Member

Ron is a practicing occupational therapist with 24 of years experience who spent 10 years specialising in patients with ALS, during which he served as Tom Lowell's prescribing therapist. Ron led the professional team responsible for the letter of medical necessity that underpinned Tom's successful application for US Medicare to fund his indoor-outdoor wheelchair.

Tom Lowell

Tom is an outdoor equipment specialist whose ALS has necessitated increasing reliance on powered mobility. Tom's willingness to publically share his story has made this paper possible.

Angus Kinnaird, BA (Hons Psych)

Angus is a professional qualitative researcher who was mainly responsible for arranging, conducting and analysing the interviews used for the case study. He was also mainly responsible for overseeing the literature review and integrating the evidence obtained into this case study, with support from Dr Rachael Schmidt.

PS10.3: Parents' Perspectives of Infants Using Modified Toy Cars

Emma Regan, BS OT

Background

Self-generated mobility is a critical factor in a child's ability to learn, play, socialise and interact with their environment (1,2). Children develop this during the preschool years through the developmental stages of crawling and walking by exploring the environment around them (3,4).

Power wheelchairs offer children with mobility impairment the opportunity to move, play, socialise and interact within their environment (5,6) Research has shown that children as young as 7 months can safely engage with specialist power mobility devices (7) however despite the feasibility of early power mobility, power wheelchairs are not frequently used by preschool children (8,9). Size, cost, environmental barriers, social acceptance and difficulty with transport have been reported as reasons power wheelchairs are rejected by parents of younger children (5,10,11).

If parents are not supportive of using power wheelchairs, children with mobility impairments are at increased risk of becoming socially isolated by failing to successfully engage with their mobile peers (12,13).

Customised electronic ride on toy cars can be used as an alternative to traditional power wheelchairs to promote independent movement for preschool children with mobility impairment (14-18). By modifying commercially available toy cars using assistive technology such children can experience self-generated movement to engage in social experience. (14-18). As little is known about parental perception of this mobility method, the aim of this study was to investigate parental perspectives of using modified electronic ride on toy cars on social interactions of preschool children with mobility impairment.

Methods

A mixed methods design was used to administer questionnaires and interviews pre and post intervention. Previous studies using toy cars have involved only single case study designs (14-17) for this reason, a small sample size of five participants can be justified in this exploratory study. Preliminary work involved discussing the research protocol with a parent of a 12-year-old disabled child, based on his experiences he recommended a two-month time period to trail the effectiveness of the toy car.

Research governance was obtained from the Belfast Health and Social Care Trust Research and Development office. Ethical approval was gained from Ulster University and the Office for Research Ethics Committees (REC16/WS/0007). The research protocol was registered as a clinical trial at

a publicly accessible database (Clinical Trials.gov ID: 15/0131). Informed consent to the research and publication of the results was obtained from each parent. Anonymity and confidentiality was assured for every participant at all stages of the research.

Participants were recruited via a charity who support people with Spina Bifida (Spina bifida, Hydrocephalus, Information, Networking, Equality SHINE). A nurse from the charity identified potential participants based on the inclusion criteria which included:

- Parents aged 18 years and over, fluent English language speakers.
- Children aged between 12 months and 47 months.
- Children unable to walk independently with no experience of using power wheelchairs.
- Children without a diagnosed learning disability
- Medically stable children who can maintain upright head positioning when seated on a flat surface.

The upper age range of the participants was limited to children considered 'preschool' in Northern Ireland, therefore under four years old. The nurse issued information leaflets to 5 families based on the inclusion criteria. The leaflet contained a reply slip which parents returned within 2 weeks. All met the inclusion criteria and were allocated a place in the study.

The participants included 3 boys and 2 girls: Child A (Girl, 13 months), Child B (Boy 16 months), Child C (Boy, 22 months), Child D (Boy, 28 months) and Child E (Girl, 37 months). Five, six volts one seater battery operated toy cars (Injusa Speedy Car) were modified to include a hand operated large switch located on the steering wheel and a seat was added which included a higher back support, elbow rests, a padded seat cushion and pelvic harness.

Figure 1. Modified car (girl's version):



Figure 2. Modified car (boy's version):



Each child was assessed using the toy car by an Occupational Therapist and a Rehabilitation Engineer pre-issue to complete bespoke modifications and all safety risk assessments were completed including a demonstration and written instructions on how to operate and care for the car.

Parents were asked to record of their feelings in a log book which was issued with the car, they also completed the Psychosocial Impact of Assistive Devices Scale (PIADS) (19) pre and post intervention to measure their expectations of car and semi-structured interviews were completed eight weeks post issue.

PIADS scores were determined using a recommended formula to calculate the mean value in each subsection (19). Descriptive analysis of pre and post PIADS scores measured expectation and evaluation of the toy car by the parents. Descriptive analysis of log books established how the record of car usage may have influenced PIADS post intervention outcome scores. Thematic analysis was used to identify and analyse themes in the interview data.

Results

Table 1. PIADS Pre/Post Intervention Results

Parent	COMPETENCE			ADAPTABILITY			SELF-ESTEEM			Total Scores		
	Pre score	Post score	Variance +/-	Pre score	Post score	Variance +/-	Pre score	Post score	Variance +/-	Pre score	Post score	Variance +/-
A	0.33	2.33	+2.00	0.50	2.33	+1.83	0.50	2.25	+1.75	1.33	6.91	+5.58
B	2.42	1.25	-1.17	2.83	1.17	-1.66	2.00	1.50	-0.50	7.25	3.92	-3.33
C	1.50	2.08	+0.58	1.5	2.5	+1.0	1.38	2.00	+0.62	4.38	6.58	+2.2
D	0.75	1.67	+0.92	0.83	0.83	0	0.50	1.88	+1.38	2.08	4.38	+2.30
E	2.17	0.75	-1.42	2.33	0.17	-2.16	2.88	0	-2.88	7.38	0.92	-6.46

Table 2: Parental Log book summaries

Topic	Parental Log Summary				
	Child A 21	Child B 14	Child C 25	Child D	Child E 21
Number of times toy car used over the 8 weeks	Parents always	Parents always	Parent mostly My child went over to it on occasions (x 8)	Parent hasn't recorded all episodes only 5 outdoors entries noted	Parents introduced it sometimes child refused other times required persuasion. Sometimes she looked for it.
Car introduced by parents or asked for by the child	Parents always	Parents always	Parent mostly My child went over to it on occasions (x 8)	Parents Child looked for it	Parents introduced it sometimes child refused other times required persuasion. Sometimes she looked for it.
Where the car was used	Home Park Hospital Relatives homes	Home Relatives homes Out for a walk	Home Relatives house	Park Outside the house on the footpath Relatives house	Home Grandparents house
Who was present when using the car?	Children, adults and Parents	Sister & parents. Cousins and Granny Friend's children.	Sister & parents Grandparent Cousins	Parents, siblings & other children	Parents, sister, cousin and grandparents.
What was your child's reaction to the car?	Child excited had a big smile on her face and shouted. Enjoys moving about and looking round, getting more confident.	Child was looking for his toys on the floor couldn't access these from the car. Child got frustrated when he couldn't access places the other kids were running to. Difficult to steer and my child got stuck and frustrated.	It involved him to a greater degree playing with his sister as he loved chasing her.	Got overwhelmed/ frustrated and wanted out on the first visit to the park. Second visit he enjoyed it more. He enjoys the first 15 mins then gets bored. I think he needs more environments to keep him stimulated.	Initially smiled using it but didn't seem keen on the car, got bored and wanted out on the floor to access her toys. It didn't maintain her interest long. She didn't look happy in it. She loved chasing her sister and being able to keep up on occasions.
Reaction of others to the car:	Cute, amazing, asked where they could get one, other children wanted to get in too.	Other kids were amazed and wanted to get into the car. Other kids wanted to help manoeuvre the car.	They thought it was brilliant. Our friends and family watched him chasing kids and crashing into things, everyone thought it was amazing.	Got a lot of interest from other kids who often wanted a go too. Parents would also ask about the car, how it worked with the steering making it go.	Adults complimented her, thought she looked grown up. Her cousins were intrigued by it. Grandparents were proud and loved seeing her have a different way of getting around.
Problems using the car:	Couldn't carry oxygen tank or peg feed on the car when required so this limited the time we could use it. I was constantly bent over to assist steering.	Accessing toys on the ground. Couldn't access places the other kids ran to. Toy struggled on inclines. Child constantly got stuck against things and you would have to correct steering. We are always conscious that we would damage the car. Bulky to transport.	No problems reported	Found it a bit slow in the first speed setting. Think it needs a bit more weight at the front for hills.	My child wasn't interested in the car. She struggles with the steering. Difficult to use in smaller environments. We were limited to using indoors as we don't have a flat outdoor area, if we had tarmac it might work better outside with the other kids using their outdoor toys. At the moment it's not the right environment with stones and grass.
Additional information recorded:	Limited time using the car as child was unwell and back in hospital over the 8 weeks.	Mother's father passed away week 1, child required surgery that week also and was hospitalised several times and generally unwell during the 8 weeks.	After 8 weeks my child has improved in his own way. The car was a brilliant experience, my child loves it.	Limited time using the car due to so many hospital appointments.	Child was unwell the first 2 weeks of the intervention period.

Interview Findings

Table 3. Summary of Interview Themes

OVERARCHING THEME 1		OVERARCHING THEME 2	
1. Social play interactions of preschool children can evoke an emotional response in parents		2. Toy car's impact on the psychosocial function of immobile preschool children	
Subtheme	Subtheme	Subtheme	Subtheme
Children's immobility causes a negative emotional response in parents	The impact on parental emotions when using the toy car	Psychosocial benefits for the child from the parent's perspective	Barriers to using the toy car can affect the child's ability to participate

(1) Social Play Interactions of Preschool Children Can Evoke an Emotional Response in Parents:

i. Children's immobility causes a negative emotional response in parents: Parents reported that play experiences before the introduction of the toy car were limited to solitary activities, with little or no interaction with other children. The adverse effect of their children being left out of social play resulted in them feeling pity and sadness towards their children:

"he was always knocking on the window when he saw kids outside and he's always shouting at his sister, and I'm like, I know you would just love to be out running about out there" (Parent C).

Parents reported they felt that lack of mobility in social experiences brought about negative emotions such as sadness and frustration in the children which heightened their feelings of pity towards their child:

"if they run off on her and they are up on their feet, she can't keep up with them and would be left behind and that would cause her to be a bit frustrated and a little bit left out and sad" (Parent E).

ii. 'The impact on parental emotions when using the toy car':

Parents reported delight and happiness at the reaction of other children to their child when using the toy car. They reported other children were more likely to approach them, and it made them central to the group play:

"they were amazing by it... they were all excited...it was like a magnet to him as such" (Parent B).

Parents described feelings of pride and happiness as they witnessed their child being the leader which gave them validation of their child being important and recognised as worthy to be followed by their peers.

Parents outlined feelings of satisfaction and contentment while watching their child use the toy car by giving positive evaluations of the positive impact on their child's psychosocial skills:

"When you see your child go from shy child hardly speaking and getting into his wee car and loving it and just smiling all the time his confidence has multiplied and his social skills are out there, verbally as well, it's like watching your child open up in front of you" (Parent D).

In contrast, one of the parents outlined a negative response to watching their child use the toy car in social play. They negatively compared the inability of their child to "get around" in the same way that the other children did, describing this as something that was difficult to cope with. This highlights that parents of immobile children need support to manage their own emotions to cope with the limitations of their child's disability.

(2) Toy Car's Impact on the Psychosocial Function of Immobile Preschool Children:

i. Psychosocial benefits for the child from the parent's perspective:

Parents conveyed that using the toy car made their child happy. They report that the toy car facilitated mobile play experiences that their children had yet to experience which improved their mood. Further, they reported increased confidence gave their child the ability to initiate social contact with other children, explore their surroundings and develop their communication skills:

"It definitely increased her ability to play.... she was definitely a lot happierand independence wise, she's a lot better" (Parent A).

ii. Barriers to using the toy car can affect the child's ability to participate in social play experiences: All of the parents outlined the biggest barrier was the child's fluctuating health status. During periods of illness the children's motivation to use the toy car was greatly impacted. The child's motivation to use the toy car and reaching toys on the ground from the car was reported as a barrier to play by parents of child B & E. Other barriers to using the toy car included difficulty with access in smaller environments uneven surfaces, inclines and inclement weather.

Discussion

Results indicate that parents perceived the toy car made a positive impact on the social interactions of all five children, however the degree of impact differed between the children. Based on post PIADS scores, four parents reported a total positive impact score above 3 whereas one (parent E) reported a positive total impact score of 0.92 reporting no impact on self-esteem.

Parent E reported their child had little motivation to use the car and had difficulty maintaining interest in social play. Furthermore, Parent D reports at the park the child was overwhelmed by the attention given by other children. Studies have shown that children with physical disabilities often experience poor social interactions with peers, leading to feelings isolation, extended periods of solitary play and feelings of rejection (20-25). This possibly reflects claims that due to their lack of experience in social play they may not possess the social skills required to initiate, maintain or cope with the interactions with their mobile peers (12,26).

Interestingly, the parents in this study reported the toy car facilitated interaction with their child's peers with children more likely to approach them. Similar findings were reported by Logan et al (2014) (15) who presented a case report on using a modified ride-on car with a 13-month old girl with Down Syndrome.

Increased social interaction using the toy car is comparable to results found in other studies using power mobility with young children. These studies reported children's increased participation in family and community life through increased integration with peers (7,27,28).

Additionally, the psychosocial improvements reported in the children in this study are consistent with earlier studies that claim that early experience of power mobility has shown to increase self-initiated behaviour (16,17) support learning (29-31), enhance cognitive development (7) improve communication skills (32) and develop social skills (5) in young children with mobility impairments.

This study reports parents felt using the toy car had a positive impact on their own emotional state. Their satisfaction with the toy car and desire to continue using it after the intervention period highlights they all viewed it as an acceptable mobility device for their child. This contradicts earlier research by Wiart and Darrah (2004) (27) who report parents view power mobility as a "last resort" used only when all other methods of mobilising have failed. Furthermore, recent research has recommended that parents should be encouraged to use power mobility with young children with less focus on achieving independent mobility but with the aim to facilitate participation, social inclusion and early exploration of the environment (14-18, 33, 34).

The small sample size means that results are limited in generalizability and without a control group it could be argued that improvements in social skills were due to the natural maturation of the children. Recommendations for further research should therefore include a larger sample size with a control group of matched pairs completed over a longer intervention period.

Conclusion

Despite the limitations of this study, it has provided evidence that parents perceived a modified electronic ride on car as an acceptable mobility device to allow their child to engage in purposeful social interactions with their peers. It demonstrates that parents experience positive emotions when they perceive their child to be engaged in meaningful social interactions. It acknowledges that use of the toy car and the child's ability to participate in social interactions can be inhibited by barriers such as ill health and environmental factors.

References

1. Missiuna C, Pollock N. Play deprivation in children with physical disabilities: The role of the occupational therapist in preventing secondary disability. *American Journal of Occupational Therapy*. 1991; 45: 882-888.
2. Uchiyama I, Anderson DI, Campos JJ, Witherington D, Frankel CB, Lejeune L, Barbu-Roth M. Locomotor experience affects self and emotion. *Developmental Psychology*. 2008; 44 (5):1225-1231
3. Kermoian R. Locomotion experience and psychological development in infancy. In: J Furmasu, ed. *Pediatric powered mobility: Developmental perspectives, technical issues, clinical approaches*. Arlington, VA: RESNA. 1997:7-22
4. Campos JJ, Anderson DI, Barbu-Roth MA, Hubbard EM, Hertenstein MJ, Witherington D Travel broadens the mind. *Infancy*. 2000; 1: 149-219
5. Guerette P, Furmasu J, Tefft D. The Positive Effects of Early Powered Mobility on Children's Psychosocial and Play Skills. *Assistive Technology*. 2013; 25: 29-48
6. Evans S, Neophytou C, De Souza L, Frank AO. Young people's experiences using electric powered indoor-outdoor wheelchairs (EPIOCs): Potential for enhancing users' development? *Disability Rehabilitation*. 2007; 29: 1281-94.
7. Lynch A, Ryu JC, Agrawal S, Galloway JC. Powered mobility training for a 7-month old infant with spina bifida. *Pediatric Physical Therapy*. 2009; 21: 362-8.
8. Rodby-Bousquet E, Hagglund G Use of manual and powered wheelchair in children with Cerebral Palsy: a cross-sectional study. *BMC Pediatrics*. 2010; 10 (1): 59.
9. Guerette P, Tefft D, Furmasu J *Pediatric powered wheelchairs: Results of a national survey of providers*. *Assistive Technology*. 2005; 17: 144-58.
10. Wiart L, Darrah J, Cook A, Hollis V, May L. Evaluation of powered mobility use in home and community environments. *Physical and Occupational Therapy in Pediatrics*. 2003; 23(2): 59-75.
11. Henderson S, Skelton H, Rosenbaum P. Assistive devices for children with functional impairments: impact on child and child giver function. *Developmental Medicine and Child Neurology*. 2008; 50 (2): 83-98.
12. Ragonesi C, Chen X, Agrawal S, Galloway JC. Power Mobility and Socialization in Preschool: A Case Report on a Child with Cerebral Palsy. *Pediatric Physical Therapy*. 2010; 22(3):322-329.
13. Bennett KS, Hay DA. The role of family in the development of social skills in children with physical disabilities. *International Journal of Disability, Development and Education*. 2007; 54(4): 381-397.
14. Huang HH, Galloway JC. Modified Ride-on toy cars for early powered mobility: a technical report. *Pediatric Physical Therapy*. 2012; 24(2): 149-154.
15. Logan SW, Huany HH, Stahlin, Galloway JC. Modified ride-on car for mobility and socialization: single-case study of an infant with down syndrome. *Pediatric Physical Therapy*. 2014; 26(4): 418-426.
16. Ragonesi C, Chen X, Agrawal S, Galloway JC. Power Mobility and Socialization in Preschool: A Case Report on a Child with Cerebral Palsy. *Pediatric Physical Therapy*. 2010; 22(3):322-329.
17. Ragonesi C, Chen X, Agrawal S, Galloway JC. Power Mobility and Socialization: Follow-up case study of a child with Cerebral Palsy. *Pediatric Physical Therapy*. 2011; 23(4):399-406.
18. Feldner HA, Logan SW, Galloway JC. Why the time is right for a radical paradigm shift in early powered mobility: the role of powered mobility technology devices, policy and stakeholders. *Disability and Rehabilitation: Assistive Technology*. 2015; 1-14, accessed August 30, 2016 doi:10.3109/17483107.2015.1079651
19. Jutai J, Day. H Psychosocial Impact of Assistive Devices Scale (PIADS). *Technology and Disability*. 2002; 14 :107-111.
20. Zurmohle UM, Homann T, Schroter C, Rothgerber H, Hommel G, Ermert JA. Psychosocial adjustment of children with spina bifida. *Journal of Child Neurology*.1998; 13: 64-70
21. Yude C, Goodman R. Peer problems of 9-11 year olds with hemiplegia in mainstream schools. Can these be predicted? *Developmental Medicine and Child Neurology*. 1999; 41: 4-8
22. Coster WJ, Haltiwanger JT. Social-behavioural skills of elementary students with physical disabilities included in general education classrooms. *Remedial and Special Education*.2004; 25: 95-103.
23. Curtin M, Clarke G. Listening to young people with physical disabilities' experiences of education. *International Journal of disability, Development and Education*. 2005; 52:195-214
24. Nassau JH, Drotar D. Social competence in children with IDDM and asthma: Child, teacher and parent reports of children's social adjustment, social performance and social skills. *Journal of Pediatric Psychology*. 1995. 20:187-204.
25. Kolb SM, Hanley-Maxwell C. Critical social skills for adolescents with high incident disabilities: Parental perspectives. *Exceptional Children*. 2003; 69:163-180.
26. Larkin D, Summer J. Implications of movement difficulties for social interaction, physical activity, play and sports. In: Dewey D, Tupper DE, editors. *Developmental motor disorders: A neuropsychological perspective*. Guildford Press; 2002.pp: 443-460.
27. Wiart L, Darrah J, Hollis V, Cook A, May L. Mothers' perceptions of their children's use of powered mobility. *Physical & Occupational Therapy in Pediatrics*. 2004; 24, 3-21.
28. Home AM and Ham R. Provision of powered mobility equipment to young children: The Whizz-Kidz experience. *International Journal of Therapy and Rehabilitation*. 2003; 10 (11) :511-517
29. Livingstone R A. Critical review of powered mobility assessment and training for children. *Disability & Rehabilitation: Assistive Technology*. 2010; 5 (6): 392-400.
30. Nilsson LM, Nyberg PJ Driving to Learn: A new Concept for Training Children with Profound Cognitive Disabilities in a Powered Wheelchair. *American Journal of Occupational Therapy*. 2003; 57: 229-233.
31. Nilsson L, Eklund M, Nyberg P. Driving to learn in a powered wheelchair: Inter-rater reliability of a tool for assessment of joystick-use. *Australian Occupational Therapy Journal*. 2011; 58, 447-454
32. Jones M, McEwen, Hansen L. Use of powered mobility for a young child with spinal muscular atrophy. *Physical Therapy*. 2003; 83(3): 253-262
33. Livingstone R, Paleg G. Practice considerations for the introduction and use of powered mobility for children. *Developmental Medicine and Child Neurology*. 2014; 56 (3): 210- 221.
34. Casey J, Paleg G, Livingstone R. Facilitating child participation through powered mobility. *British Journal of Occupational Therapy*. 2013; 76 (3): 158-160

PS10.4: Preliminary Design of Assistive Robotic Arm for Kitchen Tasks

Molly Jeffers, BS

Cheng-Shiu Chung, PhD

Abstract

Kitchen tasks that require reaching, lifting, and grasping can be a challenge for people with upper extremity disabilities. The KitchenBot aims to increase independence and assists with activities of daily living (ADLs) within the kitchen, such as cooking and cleaning. The robotic arm currently mounted on the KitchenBot (Kinova JACO arm) cannot withstand a payload greater than 3 lb. Development of a robotic arm that can perform kitchen tasks, especially those that require lifting heavy objects, will further increase the independence of KitchenBot users. Our preliminary design is an assistive robotic arm capable of a minimum payload of 10 lb and providing the flexibility required for performing kitchen tasks.

Intro

Due to the fine motor skills and upper limb strength that many kitchen tasks require, people with limited upper extremity mobility struggle with certain ADLs within the kitchen. Roughly 17.2 million people have difficulty lifting heavy objects such as a 10-lb bag of groceries, and 6.7 million people have difficulty grasping items such as dishes and utensils (Brault 2012).

Assistive robotics have been shown to increase independence of the users, leading to a better quality of life and an increased ability to complete ADLs (Romer 2005). After a focus group identified handling heavy objects, handling hot objects, and reaching for items in upper cabinets among the most desired tasks for an assistive robot, the KitchenBot was developed (Telson 2013).

The KitchenBot is an overhead robot appliance designed to increase kitchen accessibility for people with upper extremity weakness or impairment. It consists of a rail system mounted above the cabinets in a kitchen, with a vertical column connected to and free to translate along the overhead railing. Attached to the column is a robotic arm with the ability to perform a variety of kitchen tasks (Figure 1).



Figure 1. SolidWorks model of the KitchenBot system in the HERL research kitchen. Shown with the initial robotic arm, the JACO, mounted on the column.

The KitchenBot can withstand a payload of 26 lb and a torque of 80 ft-lb with minimal deflection of the track system (Telson 2013). However, no robotic arm is currently available for use with the KitchenBot that can support this payload and also perform kitchen specific tasks.

Initially the KitchenBot utilized the Kinova JACO arm. While the JACO successfully completed many fine motor skill ADLs, it was limited in tasks such as lifting heavy items and handling hot items. A review of the JACO revealed that, while lightweight and consisting of seven degrees of freedom, the maximum payload is only 3.3 lb. (Maheu 2011).

The goal of this study is to develop a robotic arm for the KitchenBot. The arm should have the ability to perform simple kitchen tasks and support a payload of at least 10 lb, with a long-term goal of withstanding a payload up to 25 lb.

Methods

The initial design of the robotic arm was based on previous surveys that determined the most necessary kitchen tasks for people with upper extremity impairments (Telson 2013, Table 1).

Table 1. Design criteria for kitchen tasks that the arm should complete, divided into the categories of reach, lift, and grasp.

Category	Task
Reach	To open/close upper cabinet doors
	Into upper cabinets to retrieve items
	Back of countertops, including sink
	To retrieve dropped items from floor
Lift	Pots, pans, other dishes
	Heavy groceries
	Food and drinks
Grasp/ Maneuver	Kitchen utensils (whisk, spoon, fork, etc.)
	Dishes
	Sink faucet, cabinet and drawer handles
	Cooking tasks (stir, pour, mix, stabilize)

The geometries of the arm were based on measurements of our research kitchen. The kitchen is similar to a standard kitchen but has adapted countertops and cabinets and contains the KitchenBot track and column system. Evaluation of the design requirements and the layout of the model kitchen led to the decision to focus only on the countertops and upper cabinets. Future work will expand focus to include lower cabinets and appliances. A simplistic design was

chosen for preliminary construction of the arm. Motors and actuators were selected for this model based on force and torque analyses. The selected actuators and motors, as well as custom designed connections, brackets and a mounting plate, were designed within SolidWorks 2015. The belt actuator and the components of the KitchenBot column were utilized, and a mounting plate was designed to attach to the actuator carriage. The parts were compiled and dimensions were measured to ensure full range of motion about the pivot point. The model will later be analyzed using SolidWorks to determine areas of improvement.

Results

Construction of the robotic arm model in SolidWorks involved force, torque, and length measurements to ensure proper parts were selected and assembled. The resultant arm design includes motors, actuators, and a pivot point (Figure 2). Points A and B make up the wrist joint, and each contain a gear motor with a maximum torque of 127 in-lb (12 VDC 25 rpm Econ Part #638342). Point A allows wrist rotation, while Point B provides wrist flexion. Point C contains a linear actuator with a stroke length of 4.33 in and a maximum force output of 787 lbf (Reac RE25 Standard). Point D is the pivot point about which the entire arm rotates. Point E contains a pin that mounts the arm to the KitchenBot column and brackets. The linear actuator at Point E has a maximum force of 1350 lbf with a stroke length of 6.89 in and provides the force that allows the arm to move to multiple positions at variable angles (Linak LA30). The dimension x is the distance from the pivot point of the arm, measured back towards the mounting point of the top of linear actuator E. The dimension d is the distance from the pivot point down to the bottom mounting point of linear actuator E and L is the hypotenuse of this geometry

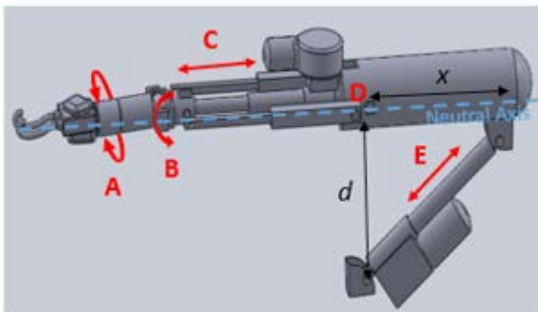

Figure 2. Final result for preliminary robot arm design, labeled at points of movement. Points A and B each contain a gearmotor, Points C and E each contain a linear actuator, while Point D acts as a pivot point for the entire system. The neutral axis and x and d dimensions are marked.

Optimal dimensions of the arm and location of the linear actuator at Point D were calculated given an applied load of 10 lb with an ideal reach distance (r) of 36 in, the measured depth of our research kitchen countertops (Table 2). The torque calculations were completed assuming the load is applied perpendicular to the arm.

Table 2. Ideal dimensions of actuator placement and the resulting force on the actuator, calculated at multiple load forces and geometric dimensions, with a constant reach of 36 inches with respect to the neutral axis.

Arm Load (lb)	r (in)	Max Torque (in-lb)	x (in)	d (in)	L (in)	Actuator Force (lb)
10	36	360	10	10	14.1	50.9
			11	11	15.6	46.3
			12	12	17.0	42.4
15	36	540	10	10	14.1	76.4
			11	11	15.6	69.4
			12	12	17.0	63.6

Of the actuators considered for Point E, the Linak LA30 was selected. Stroke length and angle range were considered in selecting the actuator (Table 3). The angle range was determined based on the assumption that any deflection up or down from neutral constituted the change in angle.

Table 3. Dimensions of the Linak LA30 actuator, including minimum and maximum actuator lengths based on stroke length, range of motion, and the geometry of the actuator placement within the model. (Datasheets for this and other models may be accessed at www.linak.com/products/linear-actuators.aspx)

x (in)	10	11
d (in)	10	11
Stroke length (in)	5.91	6.89
Length min (in)	13.0	14.0
Length max (in)	18.9	20.9
Θ down ($^{\circ}$)	51.8	53.1
Θ up ($^{\circ}$)	8.98	11.1
Θ range ($^{\circ}$)	60.8	64.2

Multiple actuators were analyzed and measured for use at the telescopic point of the robotic arm (Point C). The Reac RE25 was selected because of the stroke length and minimum and maximum overall lengths gathered from the company's data sheets (Table 4).

Table 4. Dimensions of the Reac RE25 linear actuator, including minimum and maximum lengths and stroke length. (Datasheets for this and other models may be accessed at www.reac.se/sv/products.html)

Stroke length (in)	Length min (in)	Length max (in)
4.33	9.13	13.5
5.91	10.7	16.6

Force and torque measurements (Table 5) were calculated based on a free body diagram of the robotic arm model (Figure 3). The torque at each of the joints was found using the measured distance from the applied load to the particular joint. Due to the research kitchen dimensions, the preliminary model had a maximum reach distance of 26.5 in and resultant torques and forces were calculated at this distance (Table 5).

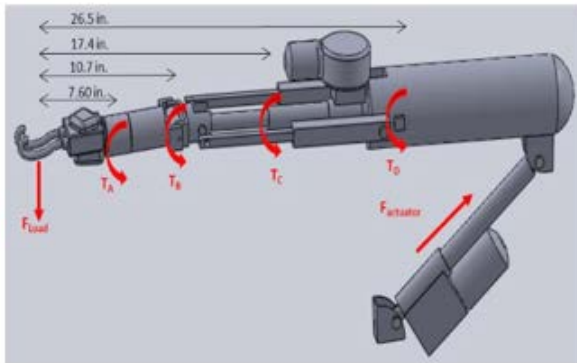

Figure 3. Free body diagram of robotic arm model. When the robot arm is fully extended Point A is 7.60 in., Point B is 10.7 in., Point C is 17.4 in., and Point D is 26.5 in. from the applied load.

Table 5. Forces present at each motor or actuator due to an applied load located at the hook end of the arm. Calculated values are based on the geometry and forces present in the free body diagram of the current model (Figure 3).

Applied Arm Load (lb)	10	15	20
Torque A (in-lb)	76	114	152
Torque B (in-lb)	107	161	214
Torque C (in-lb)	265	398	530
Torque D (in-lb)	265	398	530
Force E (lb)	34.1	51.1	68.1

The mounted robotic arm has a range of motion of 64.2° and five degrees of freedom (Figure 4). The arm can move in multiple directions and positions, with no extension or rotation at any joints (Figure 4A) or with full or partial extension at the joints (Figure 4B). The arm also moves vertically on the KitchenBot column and has the ability to maneuver throughout the SolidWorks model of the HERL research kitchen (Figure 5).



Figure 4. Side view of the robotic arm in (A) the neutral position with no extension or rotation of any motors or actuators, and (B) a position that demonstrates movement of the joints with each joint having partial extension and/or rotation.

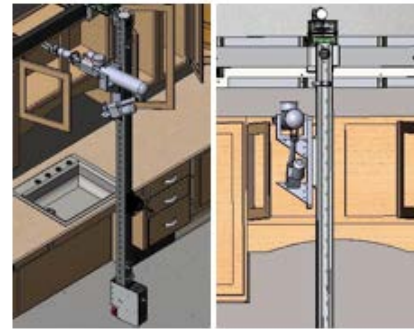

Figure 5. Robotic arm mounted to KitchenBot and shown within a model of the HERL kitchen showing (A) an isometric view and (B) a view from the back of the system.

Discussion

The focus of this project was to design an assistive robotic arm with a minimum payload of 10 lb, with the long-term goal of a payload up to 25 lb, consistent with the payload of the KitchenBot track system.

The design criteria was developed based on evaluation of the needs expressed by people with disabilities. Certain tasks and areas of the kitchen were not taken into account during this project due to time and physical space constraints of the HERL kitchen. The space between the lower cabinets and the KitchenBot column is only 7 in and requires a robotic arm more flexible than the current design. An arm with this amount of flexibility with the ability to support the necessary payload was determined to be beyond the scope of this project.

A Motion Control ETD prosthetic hook was used at the end of the arm because of its durability and precision in completing most tasks. One study determined that a simple split hook prosthesis can perform equally well at most tasks and better at some tasks when compared to a myoelectric hand prosthesis (Agnew 1981). While some tasks require fine motor skills, the kitchen tasks outlined in the design criteria can be successfully completed with a simple, durable split hook. The dimensions for the back of the arm were chosen to allow the actuator located at the back of the arm to achieve the largest range of motion and a minimized force. When the location dimensions were changed from 10 to 11 in, the force on the actuator decreased (50.9 to 46.3 lb) and the angle range increased (60.8° to 64.2°).

The LA30 actuator was chosen for this model due to the large angle range and reasonable stroke length (6.89 in). The angle range calculated with SolidWorks was the largest range for the Linak actuators (64.2°). The advantage of a large angle range allows the arm to extend to hard to reach places, increasing the overall area that the arm can access.

The gear motors chosen for the wrist joints at Points A and B were selected due to their small size and weight, in addition to their power and torque. The measurements indicated that the motors needed to be fairly powerful to support a 10-lb load. The maximum torque of the Econ gear motor (127 in-lb) is sufficient for an applied load of 10 lb. A small diameter (0.98 in) and length (2.27 in), allowed the motor to take up little space within the arm, increasing maneuverability and flexibility within the small space of the kitchen cabinets.

The selection of the gear motors allowed the telescoping actuator to be chosen based on the amount of space the motors occupied. The prosthetic hook, motors, and connection pieces occupied a specific area, meaning the size of the telescopic actuator was limited. Of the Reac actuators examined, only the RE25 standard size had a minimum length that allowed the retracted arm to fit within the space between the cabinets and KitchenBot column. This constraint led to a limited maximum reach of 26.5 in, instead of the ideal 36 in needed to reach the back of the HERL kitchen countertops and cabinets.

The SolidWorks model of the arm design confirmed the selected dimensions and components fit within the model kitchen. The upper cabinets could be reached and the countertops could be reached as far back as 26.5 in. Based on the calculations and force and torque analyses the selected components will withstand a 10-lb load.

Future Work

Future research will focus on parts selection to ensure selection of a telescopic actuator that fits within the allotted space and reaches the ideal distance (36 in). Finite element analysis will aid in selecting parts and improving custom designed components. FEA will provide information regarding the specific areas of the design that require improvement and confirm the load limit of the selected and designed components.

Further designs will work on increasing flexibility and degrees of freedom of the arm, which will allow the arm to retract and extend in multiple directions, increasing the area within the kitchen that the arm can access and the tasks the arm can complete. The design team will continue to work toward the long term goal of supporting a 25-lb payload.

Acknowledgements

This research was supported by the Human Engineering Research Laboratories and the Department of Veterans Affairs at the University of Pittsburgh. It was made possible by the following: QoLT REU #0540866; ASPIRE REU Grant #1262670; ELeVATE Grant #1232336; VA Center Grant #B6789C.

References

1. Agnew, P. J. (1981, August). Functional effectiveness of a myoprosthesis compared with a functional split hook prosthesis: A single subject experiment. *Prosthetics and Orthotics International*, 5(2), 92-96. Retrieved July, 2016, from MEDLINE.
2. Brault, M. (2012, July). *Americans With Disabilities: 2010 Household Economic Studies*. United States Census Bureau, 8-9. Retrieved July, 2016.
3. Maheu, V., Frappier, J., Archambault, P. S., & Routhier, F. (2011). Evaluation of the JACO robotic arm: Clinico-economic study for powered wheelchair users with upper-extremity disabilities. *2011 IEEE International Conference on Rehabilitation Robotics*, 1-5. Retrieved June, 2016, from IEEE.
4. Romer, G., Stuyt, H., & Peters, A. (2005). Cost-Savings and Economic Benefits Due to the Assistive Robotic Manipulator (ARM). *9th International Conference on Rehabilitation Robotics*, 2005. ICORR 2005., 201-204. Retrieved June, 2016, from IEEE.
5. Telson, J., Ding, D., McCartney, M., & Cooper, R. (2013). Preliminary Design Of An Overhead Kitchen Robot Appliance. *2013 RESNA Annual Conference*, Seattle Washington, 1-4. Retrieved May, 2016.

Contact

Molly Jeffers

North Carolina State University
Raleigh, NC
United States
mkjeffer@ncsu.edu

The ISS Would Like to Acknowledge the Following Supporters

Bronze:



Partner:





RSTce

Department of Rehabilitation Science and Technology
Continuing Education
School of Health and Rehabilitation Sciences
University of Pittsburgh

Seek Continuing Education with Academic Integrity...

- Online/On-Demand Webinars
- RESNA Exam Review Course
- Fundamentals of Wheeled Mobility and Seating Course
- Conferences
- Workshops
- CEU Course Certification

www.rstce.pitt.edu

Mark R. Schmeler, PhD, OTR/L, ATP

Director, Continuing Education Program & International Seating Symposium

Department of Rehabilitation Science and Technology,
School of Health and Rehabilitation Sciences, **University of Pittsburgh**

Bakery Square, Suite 401
6425 Penn Avenue
Pittsburgh, PA 15206
412.383.6917 (phone)
412.624.6120 (fax)
<http://www.rstce.pitt.edu>